

0. MOTIVATION
1. PROBLEM-SOLVING
2. INFORMATION
3. COUNTING
4. BITS
5. CODES
6. ANALOG VS. DIGITAL
7. ALGORITHMS
8. LOGIC AND ARITHMETIC
9. COMPUTERS
10. MEMORY

The slides are meant as visual support for the lecture.
They are neither a documentation nor a script.

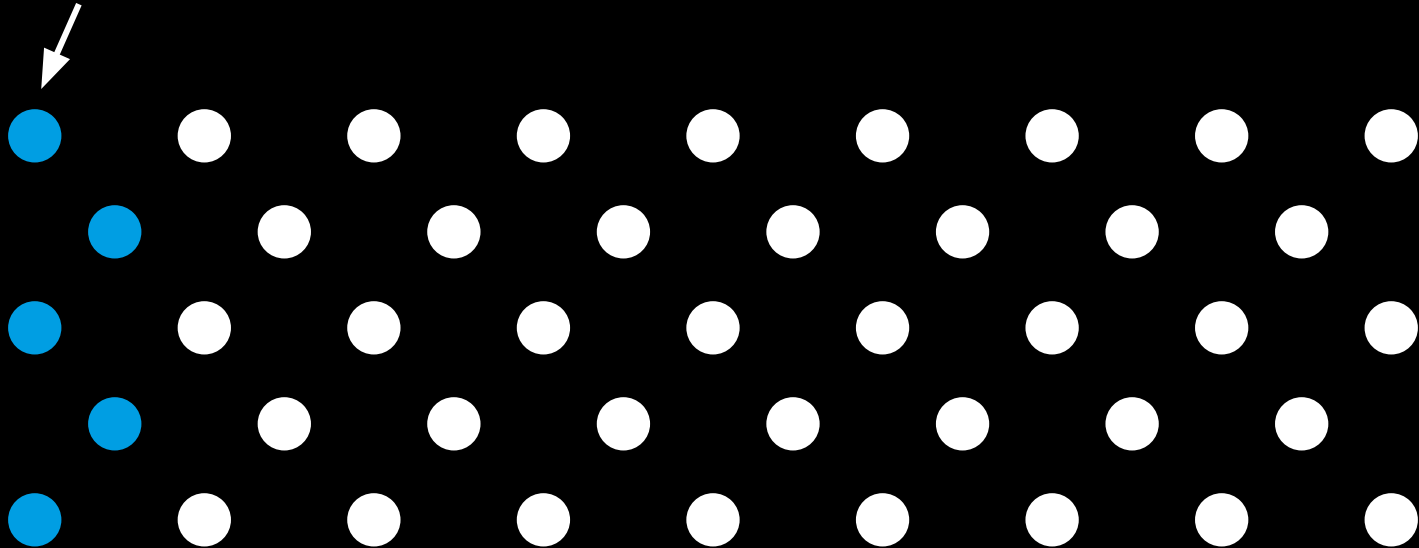
Please consider the environment before printing the slides.

Comments and feedback at n.meseth@hs-osnabrueck.de

MOTIVATION

a few
experts

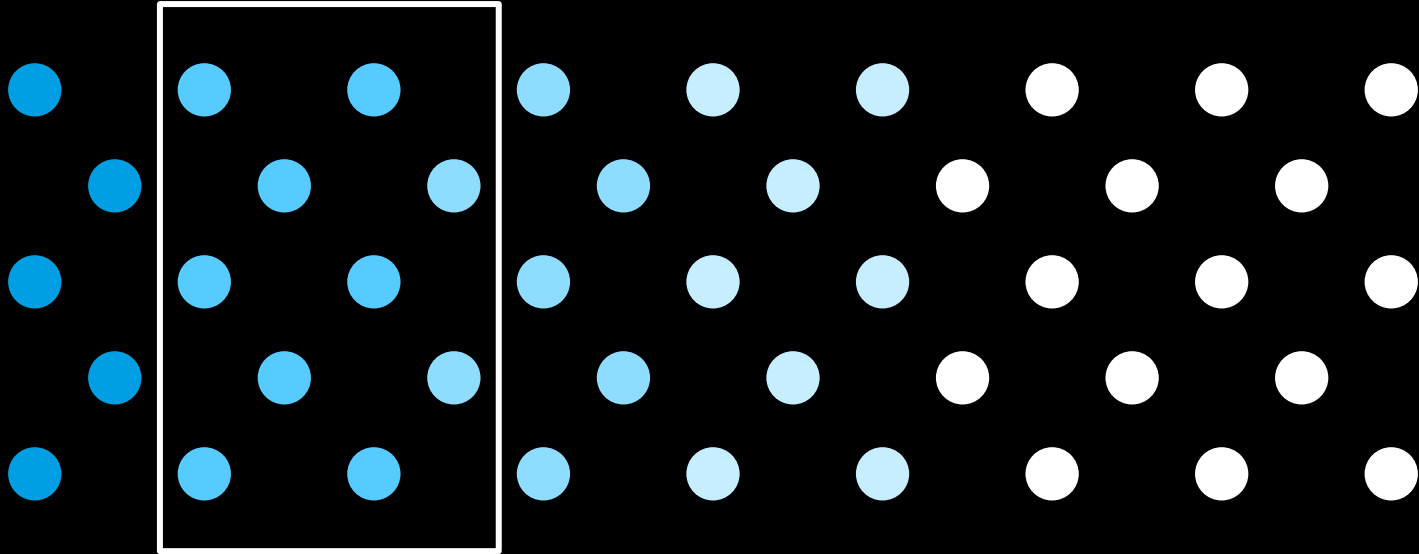
digitally uneducated
society



digitally illiterate society with a few experts

collective understanding

you?



society with a distributed and high degree of digital education

representation

representation

processing

representation

processing

programming

representation

processing

programming

digital fundamentals

data analysis

representation

processing

programming

digital fundamentals

data analysis

artificial
intelligence

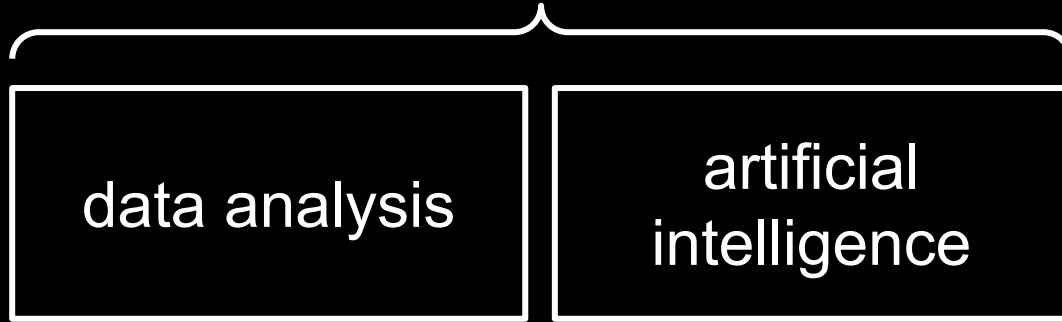
representation

processing

programming

digital fundamentals

digital applications



digital fundamentals

digital applications

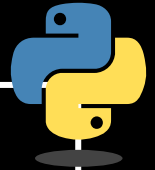
data analysis

artificial
intelligence

representation

processing

programming



digital fundamentals

digital applications

data analysis

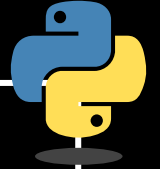
artificial
intelligence



representation

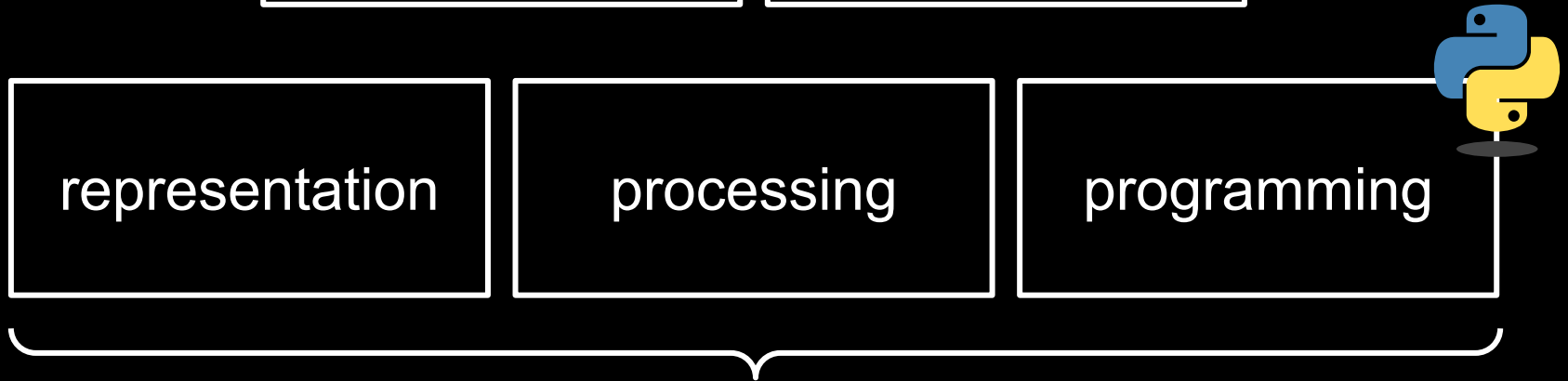
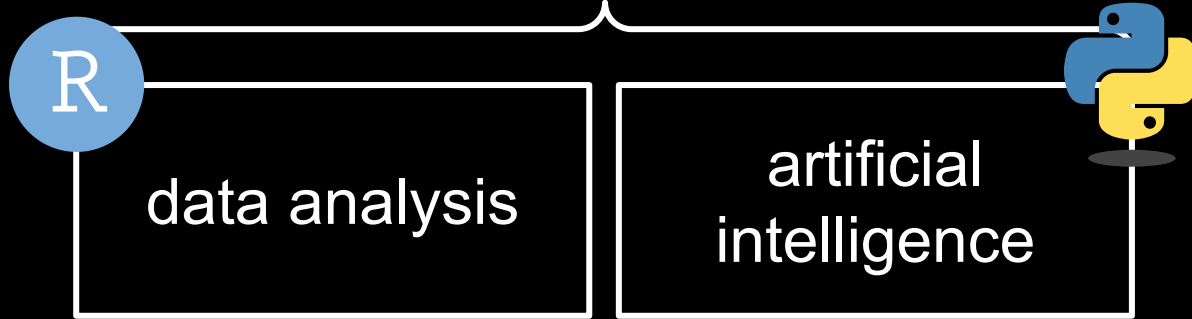
processing

programming



digital fundamentals

digital applications



digital fundamentals

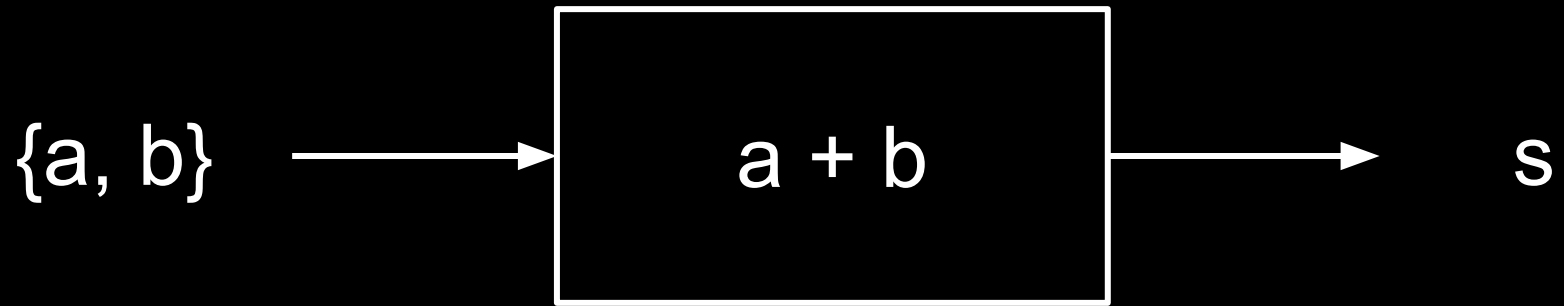
PROBLEM SOLVING

a model for solving problems

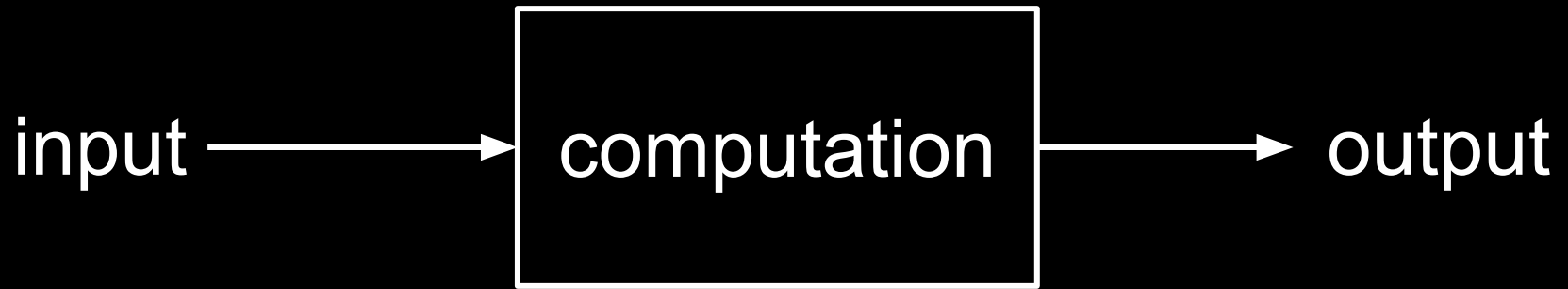


a model for solving problems

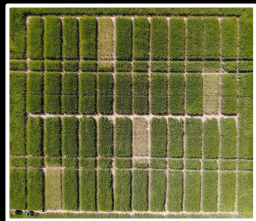




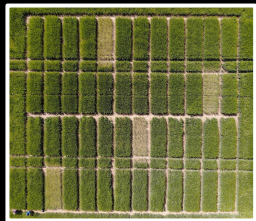
a model for solving problems





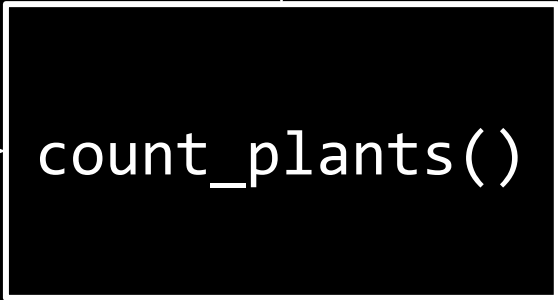
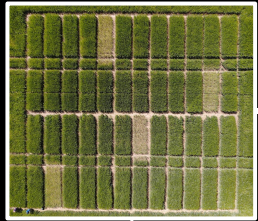


output



42

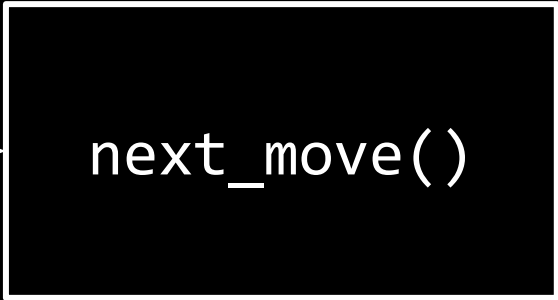
processing of
information



42

representation of
information





E2 → E4

problem solving strategies

divide and conquer

large and complex problem

smaller problem

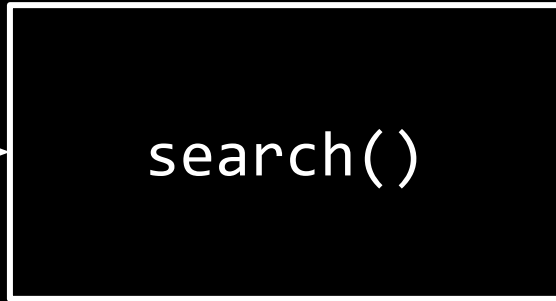
smaller problem

smaller problem

smaller problem

even smaller problem	smaller problem
even smaller problem	
smaller problem	smaller problem

sorted list +
element



yes / no

is 67 a prime number?

2, 3, 5, 7, 11, 13, 17, 19, 23, 29, 31, 37, 41,
43, 47, 53, 59, 61, 67, 71, 73, 79, 83, 89, 97

linear search



~~2~~, 3, 5, 7, 11, 13, 17, 19, 23, 29, 31, 37, 41,
43, 47, 53, 59, 61, 67, 71, 73, 79, 83, 89, 97

linear search



2, 3, 5, 7, 11, 13, 17, 19, 23, 29, 31, 37, 41,
43, 47, 53, 59, 61, 67, 71, 73, 79, 83, 89, 97

linear search



2, 3, 5, 7, 11, 13, 17, 19, 23, 29, 31, 37, 41,
43, 47, 53, 59, 61, 67, 71, 73, 79, 83, 89, 97

linear search



2, 3, 5, 7, 11, 13, 17, 19, 23, 29, 31, 37, 41,
43, 47, 53, 59, 61, 67, 71, 73, 79, 83, 89, 97

linear search

2, 3, 5, 7, ~~11~~, ~~13~~, 17, 19, ~~23~~, ~~29~~, ~~31~~, ~~37~~, 41,
~~43~~, ~~47~~, ~~53~~, 59, ~~61~~, 67, 71, 73, 79, 83, 89, 97

↑

19 steps... can't we do better?

2, 3, 5, 7, ~~11~~, ~~13~~, 17, 19, ~~23~~, ~~29~~, ~~31~~, ~~37~~, ~~41~~,
~~43~~, ~~47~~, ~~53~~, ~~59~~, ~~61~~, 67, 71, 73, 79, 83, 89, 97

↑

large and complex problem

2, 3, 5, 7, 11, 13, 17, 19, 23, 29, 31, 37, 41,
43, 47, 53, 59, 61, 67, 71, 73, 79, 83, 89, 97

large and complex problem

2, 3, 5, 7, 11, 13, 17, 19, 23, 29, 31, 37, 41,
43, 47, 53, 59, 61, 67, 71, 73, 79, 83, 89, 97

smaller problem

2, 3, 5, 7, 11, 13, 17, 19, 23, 29, 31, 37, 41

smaller problem

43, 47, 53, 59, 61, 67, 71, 73, 79, 83, 89, 97

binary search

2, 3, 5, 7, 11, 13, 17, 19, 23, 29, 31, 37, 41,
43, 47, 53, 59, 61, 67, 71, 73, 79, 83, 89, 97

binary search

67 != 41



2, 3, 5, 7, 11, 13, 17, 19, 23, 29, 31, 37, ~~41~~,
43, 47, 53, 59, 61, 67, 71, 73, 79, 83, 89, 97

binary search

67 > 41



2, 3, 5, 7, 11, 13, 17, 19, 23, 29, 31, 37, 41,
43, 47, 53, 59, 61, 67, 71, 73, 79, 83, 89, 97

binary search

67 > 41



2, 3, 5, 7, ~~11~~, ~~13~~, 17, 19, ~~23~~, ~~29~~, 31, 37, 41,
43, 47, 53, 59, 61, 67, 71, 73, 79, 83, 89, 97

binary search

~~2~~, ~~3~~, 5, 7, ~~11~~, ~~13~~, 17, 19, ~~23~~, ~~29~~, 31, 37, 41,
43, 47, 53, 59, 61, 67, 71, 73, 79, 83, 89, 97



67 != 71

binary search

~~2~~, ~~3~~, 5, 7, ~~11~~, ~~13~~, 17, 19, ~~23~~, ~~29~~, ~~31~~, ~~37~~, ~~41~~,
43, 47, 53, 59, 61, 67, ~~71~~, 73, 79, 83, 89, 97



67 != 71

binary search

2, 3, 5, 7, ~~11~~, ~~13~~, 17, 19, ~~23~~, ~~29~~, 31, 37, 41,
43, 47, 53, 59, 61, 67, ~~71~~, ~~73~~, ~~79~~, ~~83~~, ~~89~~, 97



67 < 71

binary search

2, 3, 5, 7, ~~11~~, ~~13~~, 17, 19, ~~23~~, ~~29~~, 31, 37, 41,
43, 47, 53, ~~59~~, 61, 67, ~~71~~, ~~73~~, ~~79~~, ~~83~~, ~~89~~, 97



67 != 59

binary search

2, 3, 5, 7, ~~11~~, ~~13~~, 17, 19, ~~23~~, ~~29~~, 31, 37, 41,
~~43~~, 47, ~~53~~, 59, 61, 67, ~~71~~, ~~73~~, 79, ~~83~~, ~~89~~, 97



67 > 59

binary search

2, 3, 5, 7, ~~11~~, ~~13~~, 17, 19, ~~23~~, ~~29~~, 31, 37, 41,
~~43~~, ~~47~~, ~~53~~, ~~59~~, 61, 67, ~~71~~, ~~73~~, ~~79~~, ~~83~~, ~~89~~, 97



67 = 67

binary search

2, 3, 5, 7, ~~11~~, ~~13~~, 17, 19, ~~23~~, ~~29~~, 31, 37, 41,
~~43~~, 47, ~~53~~, 59, ~~61~~, 67, ~~71~~, ~~73~~, 79, ~~83~~, ~~89~~, 97



67 = 67

3 splits → much better

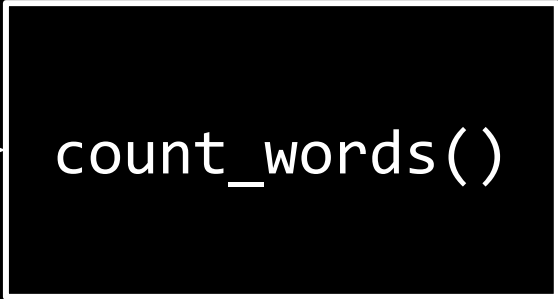
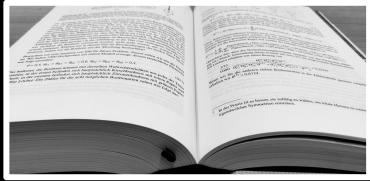
2, 3, 5, 7, ~~11~~, ~~13~~, 17, 19, ~~23~~, ~~29~~, 31, 37, 41,
~~43~~, 47, ~~53~~, 59, ~~61~~, 67, ~~71~~, ~~73~~, 79, ~~83~~, ~~89~~, 97



$$67 = 67$$

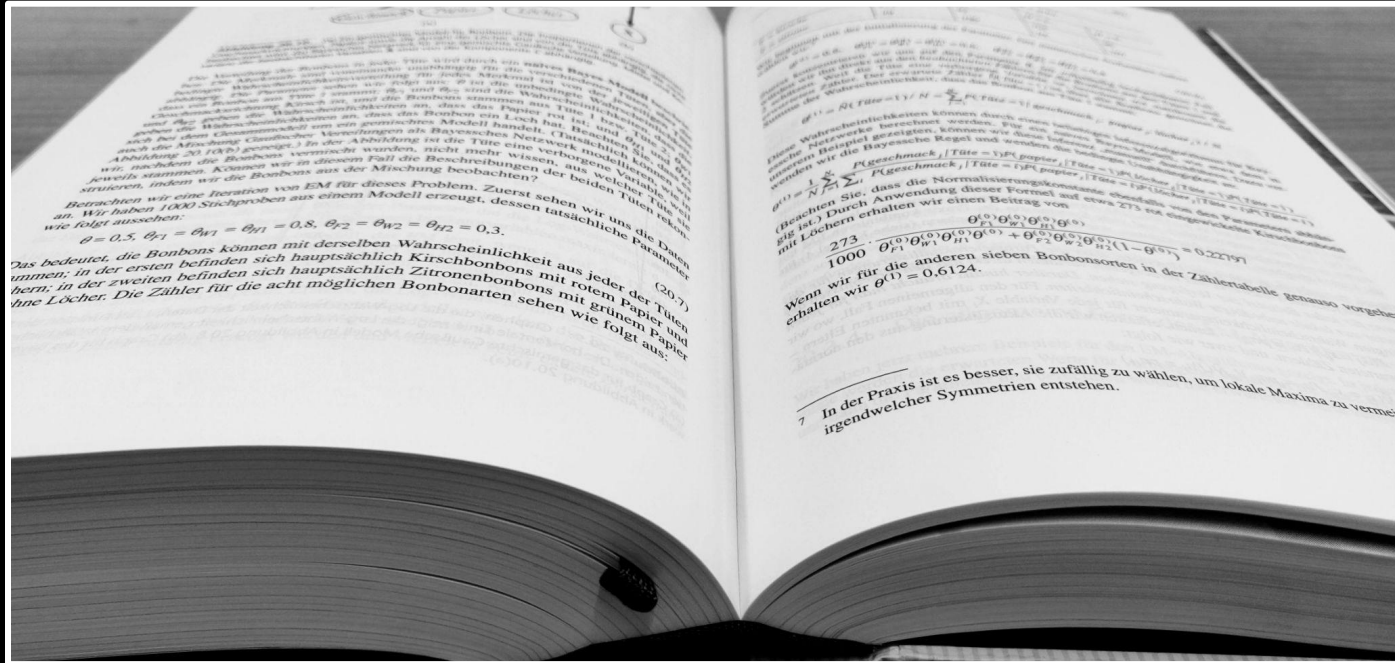


how efficient are linear and
binary search in general?

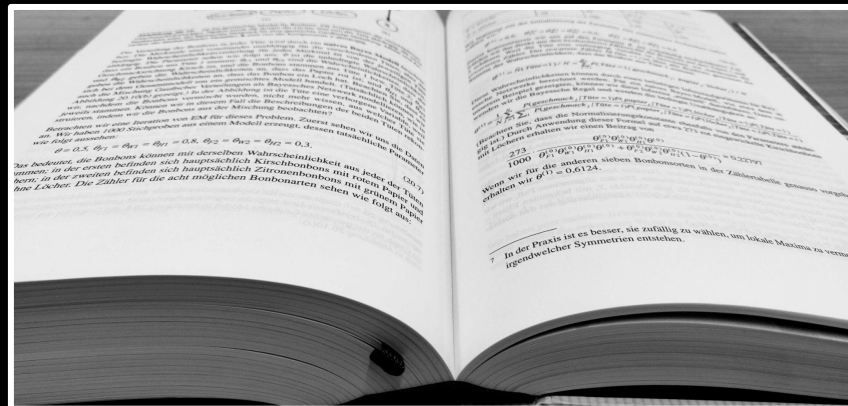


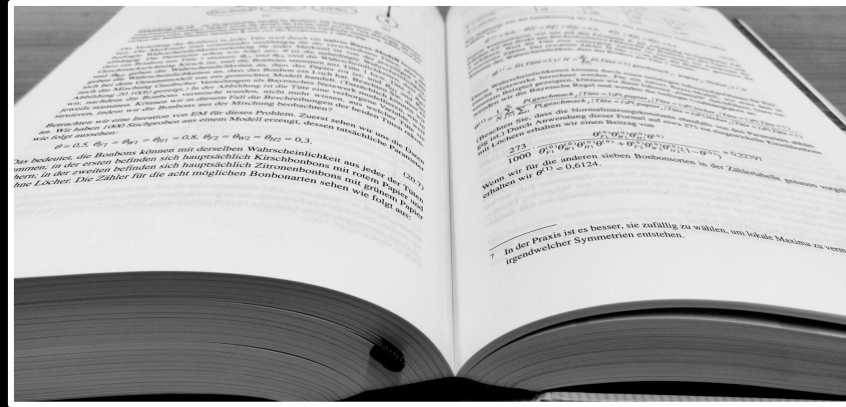
word count

how many words are in the book?

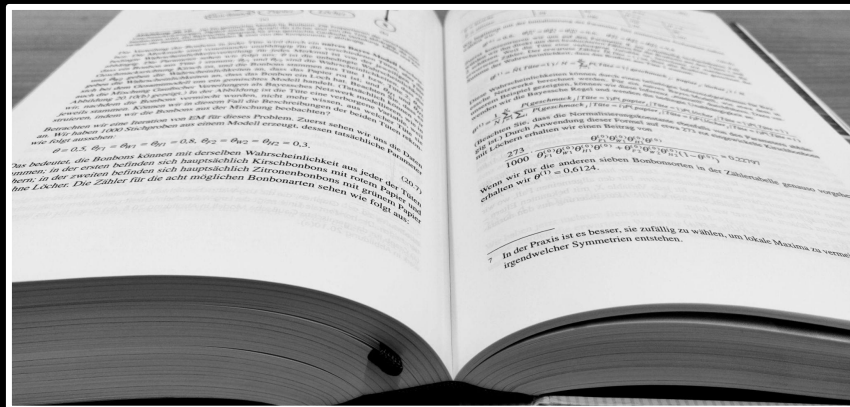


strategies, anyone?





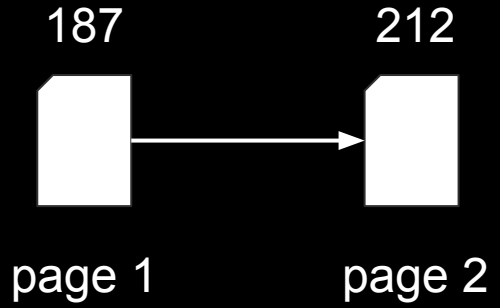
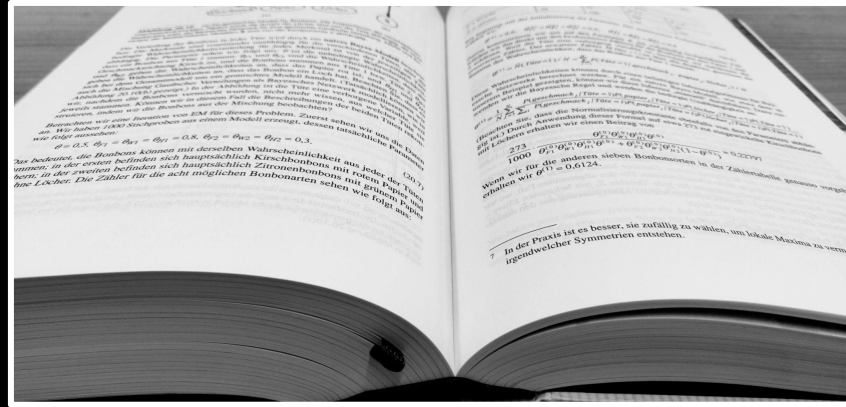
page 1

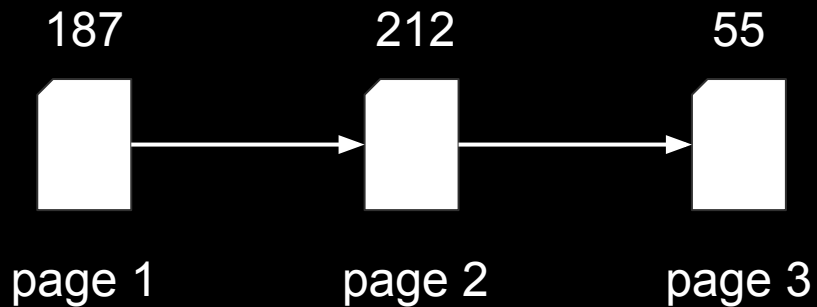
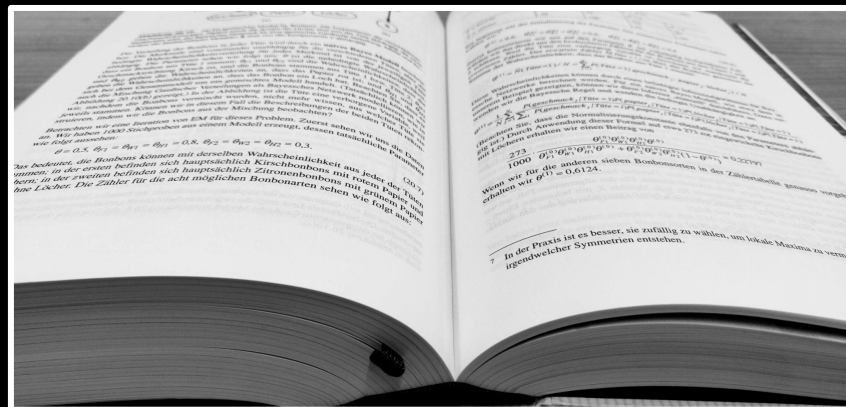


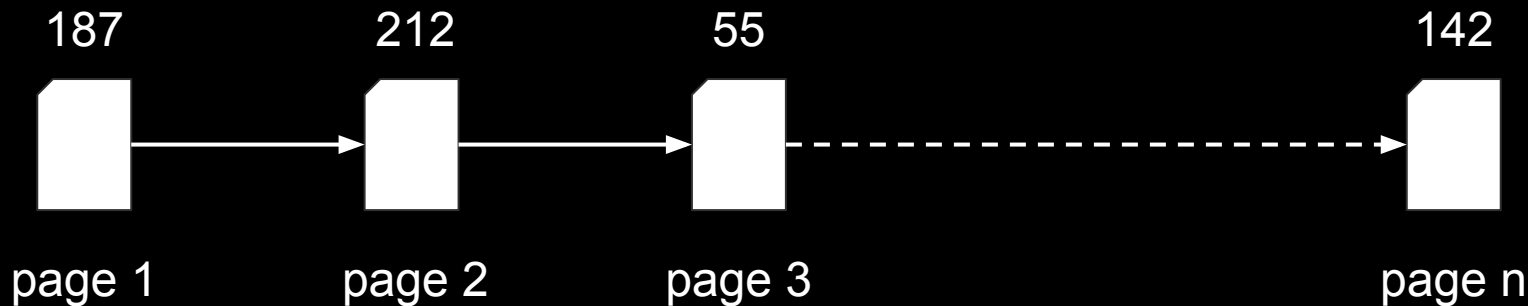
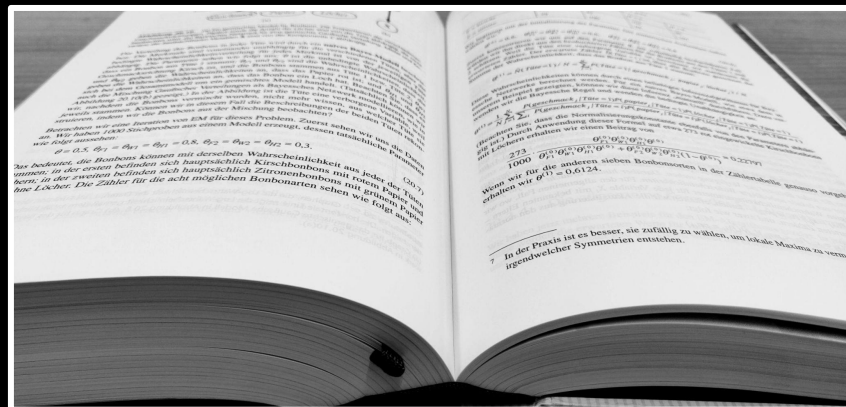
187

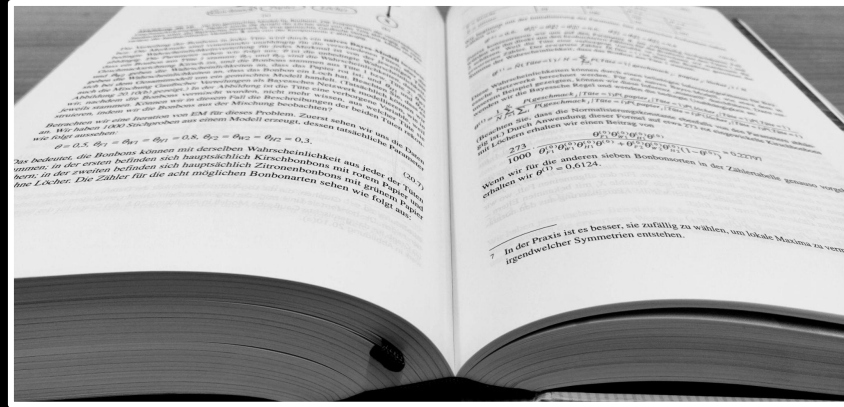


page 1









n = 1327 pages

Ø 2:23 minutes per page

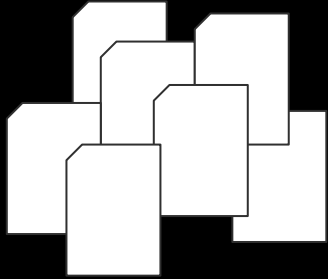
~ 52.34 hours

divide and conquer

+

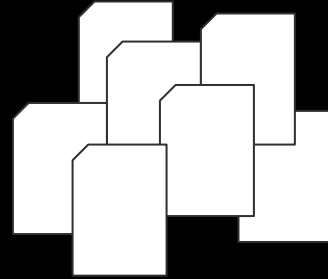
?

pages 1 - 700



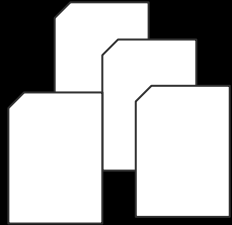
student 1

pages 701 - 1327



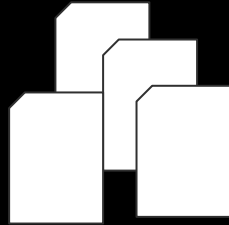
student 2

pages 1 - 350



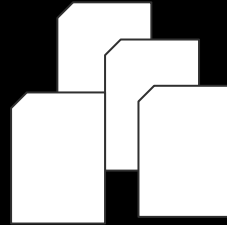
student 1

pages 351 - 700



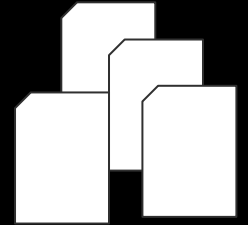
student 2

pages 701 - 1050



student 3

pages 1051- 1327

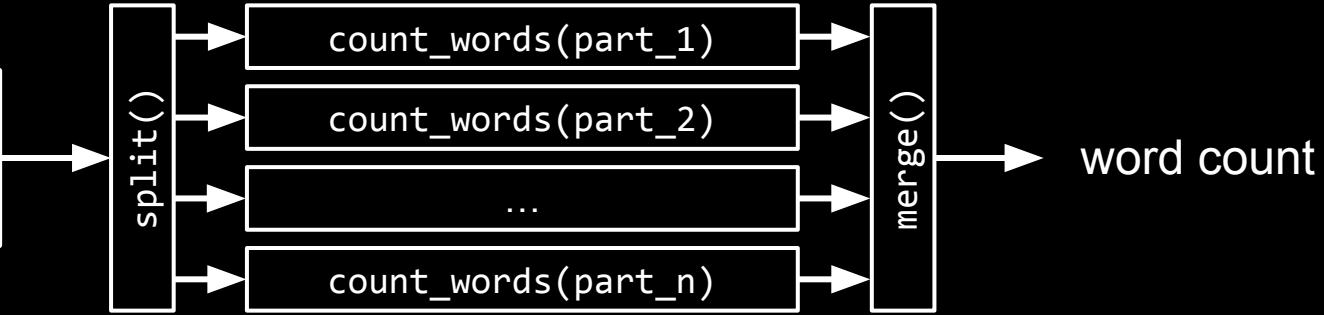
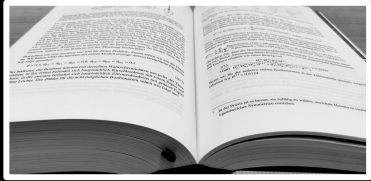


student 4

divide and conquer

+

distribution and parallelization



INFORMATION

“Information is that which allows you to make a correct prediction with accuracy better than chance.”

Adami, Christoph. “What Is Information?” *Philosophical Transactions of the Royal Society A: Mathematical, Physical and Engineering Sciences*, vol. 374, no. 2063, Mar. 2016, p. 20150230, <https://doi.org/10.1098/rsta.2015.0230>.

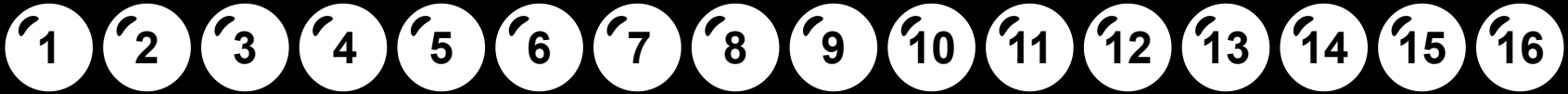
“Information is that which allows you to make a correct prediction with accuracy better than chance.”

Adami, Christoph. “What Is Information?” *Philosophical Transactions of the Royal Society A: Mathematical, Physical and Engineering Sciences*, vol. 374, no. 2063, Mar. 2016, p. 20150230, <https://doi.org/10.1098/rsta.2015.0230>.

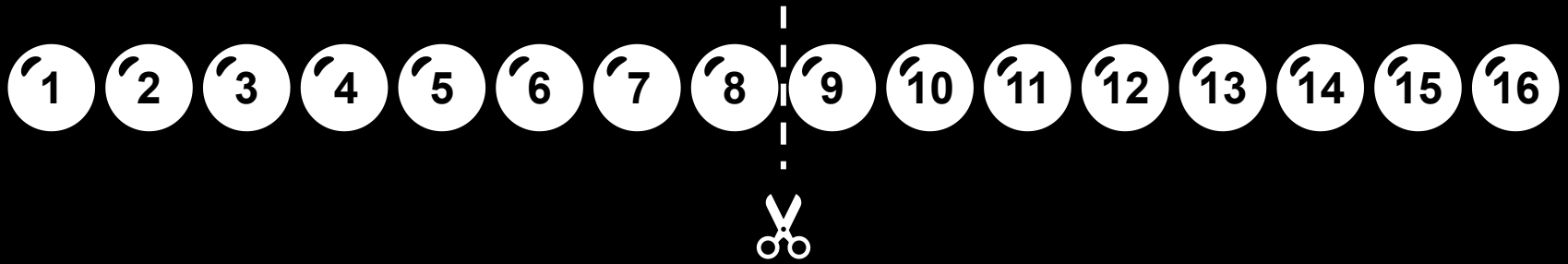
defining and measuring information

guess the number am I thinking of!

what is the most efficient approach?



is it > 8?

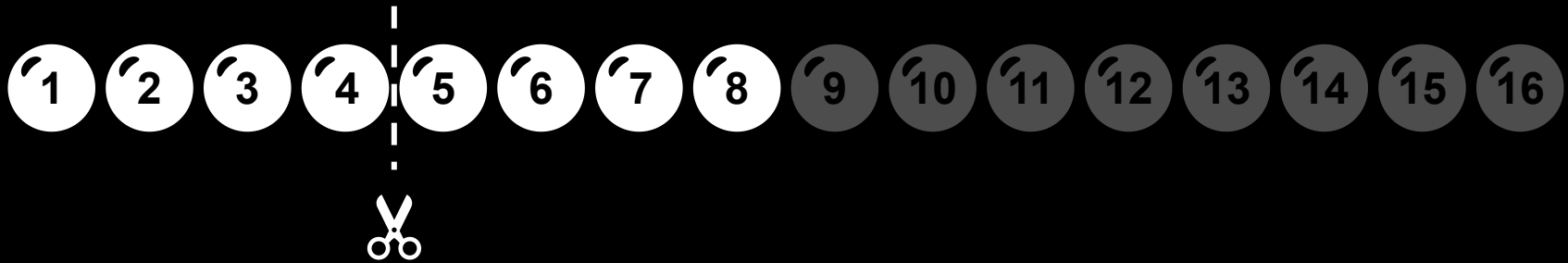


is it > 8? ✖



is it > 8? ✖

is it > 4?



is it > 8? ✗

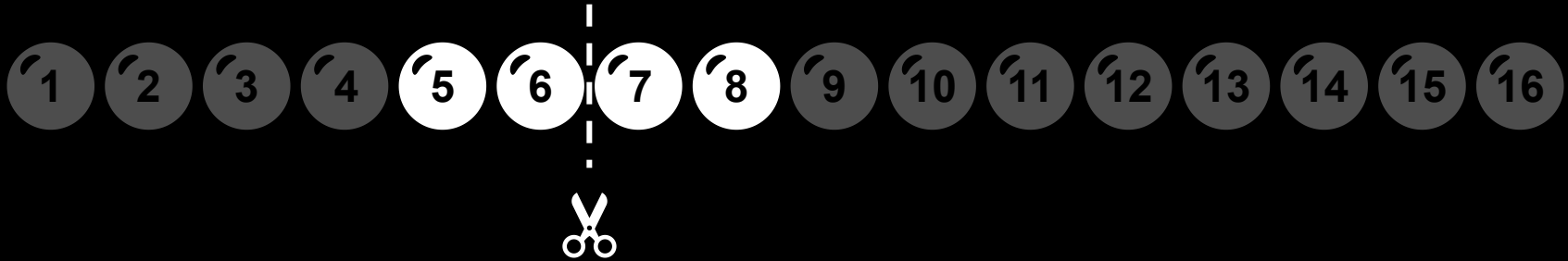
is it > 4? ✓



is it > 8? ✗

is it > 4? ✓

is it > 6?



is it > 8? ✗

is it > 4? ✓

is it > 6? ✓

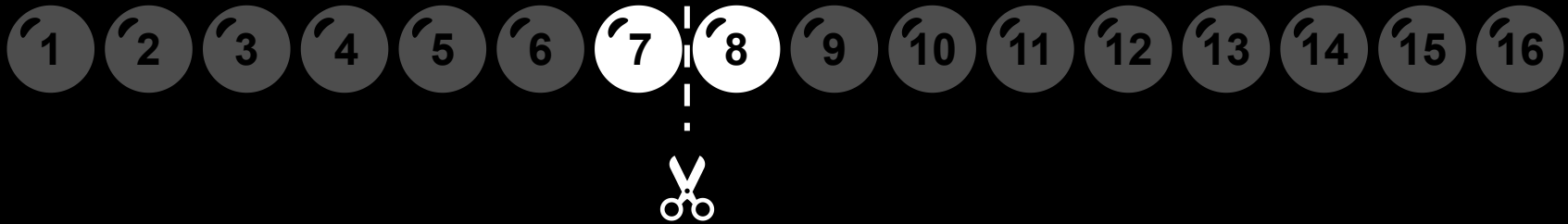


is it > 8? ✖

is it > 4? ✔

is it > 6? ✔

is it > 7?



is it > 8? ✗

is it > 4? ✓

is it > 6? ✓

is it > 7? ✗



is it > 8? ✗

is it > 4? ✓

is it > 6? ✓

is it > 7? ✗



with 4 questions from 16 to 1

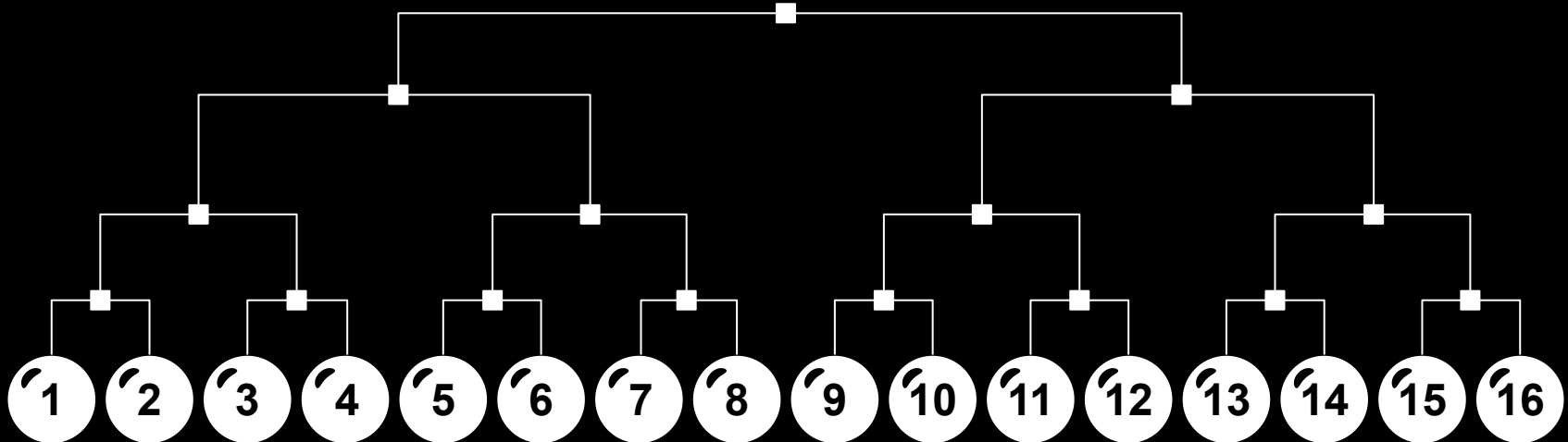
is it > 8?	✗	}	0
is it > 4?	✓		1
is it > 6?	✓		1
is it > 7?	✗		0



with 4 questions from 16 to 1

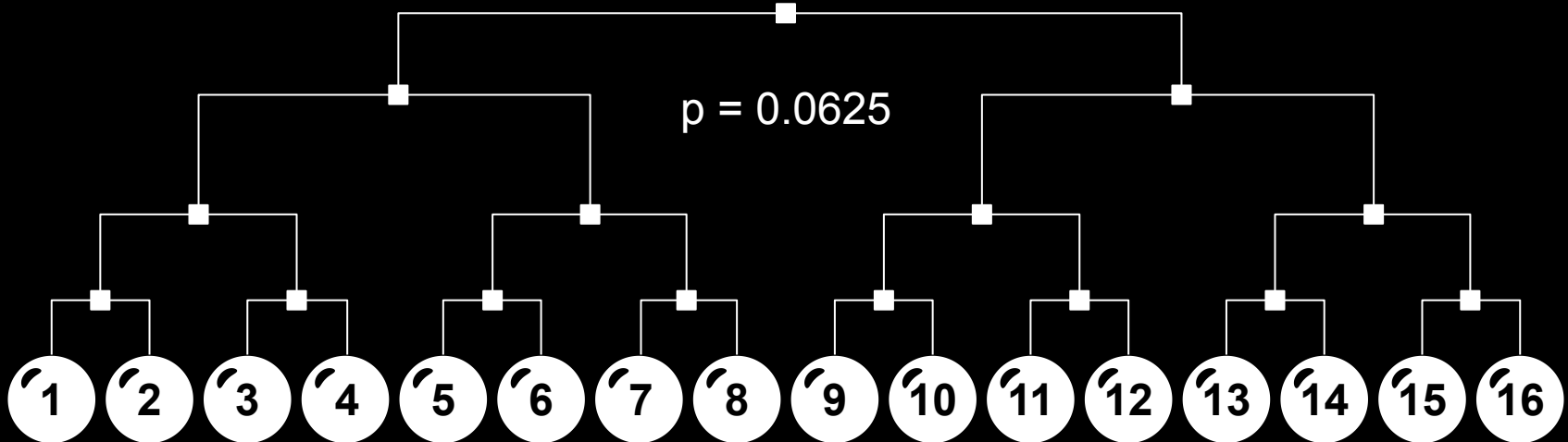
where is the information?

where is the information?



where is the information?

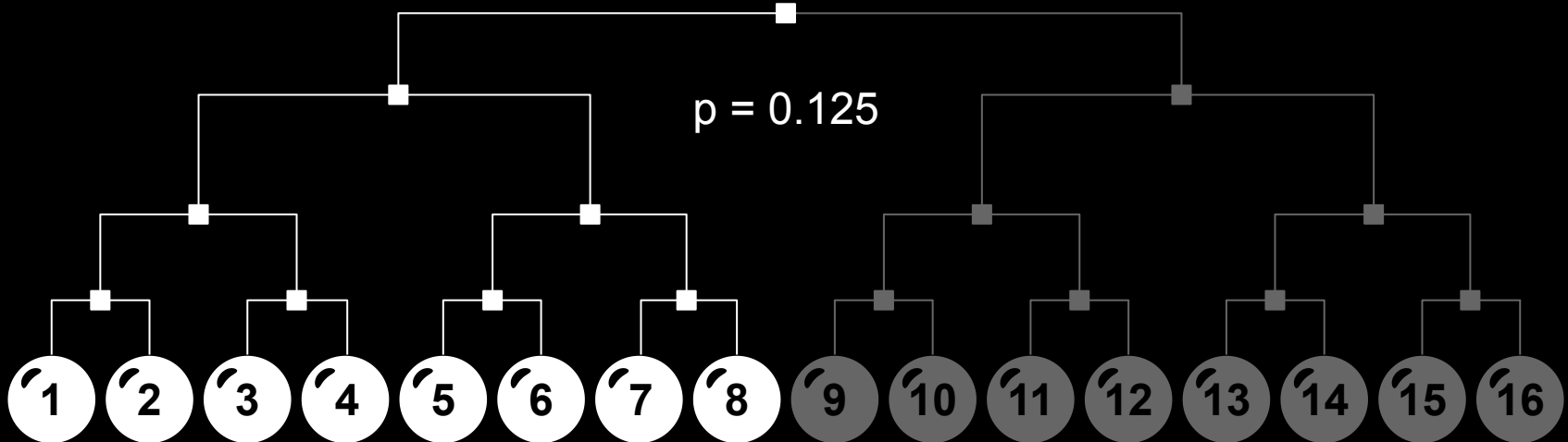
$N = 16$



where is the information?

~~N = 16~~

N = 8

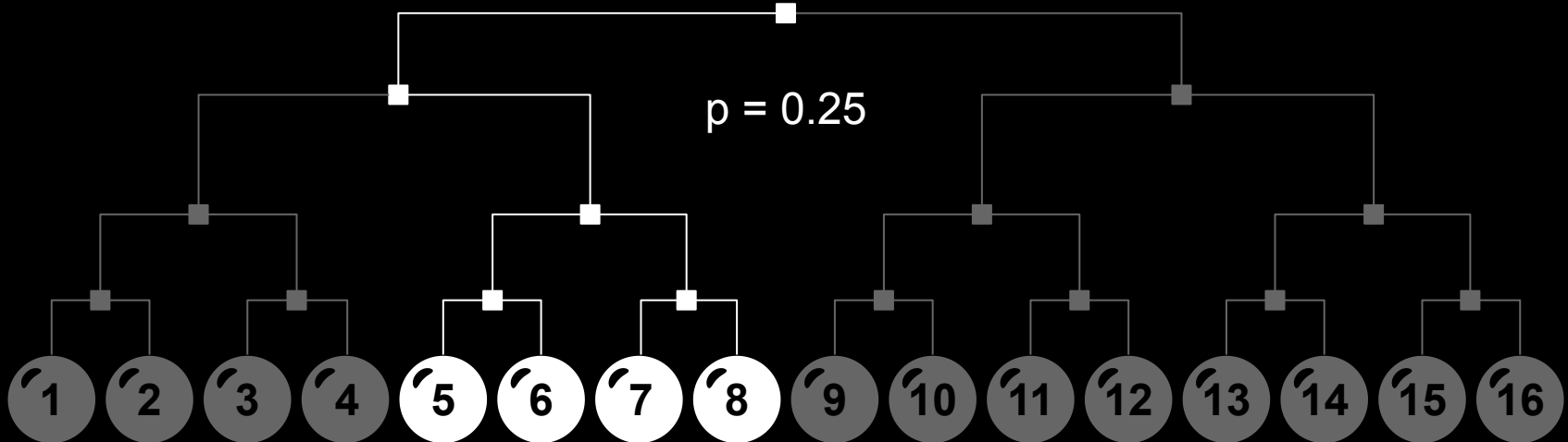


where is the information?

~~N = 16~~

~~N = 8~~

N = 4



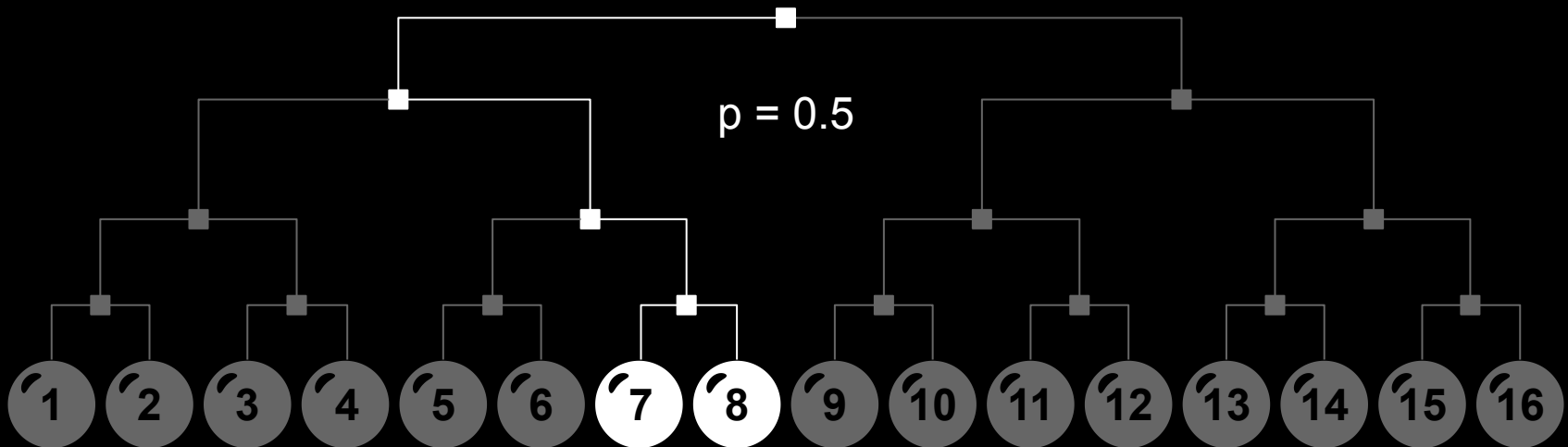
where is the information?

~~N = 16~~

~~N = 8~~

~~N = 4~~

N = 2



where is the information?

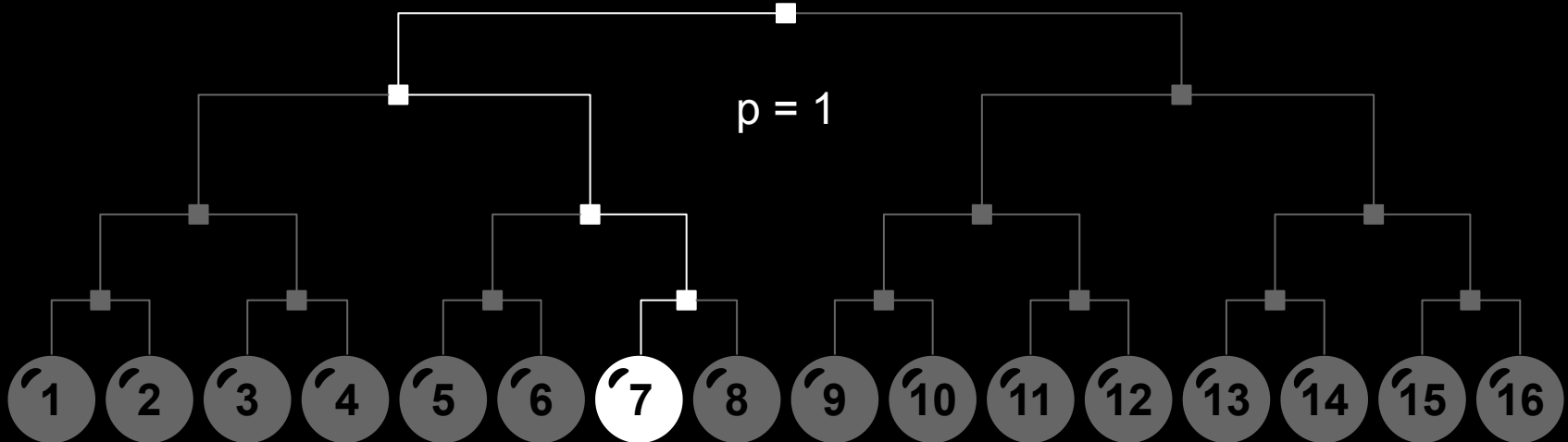
~~N = 16~~

~~N = 8~~

~~N = 4~~

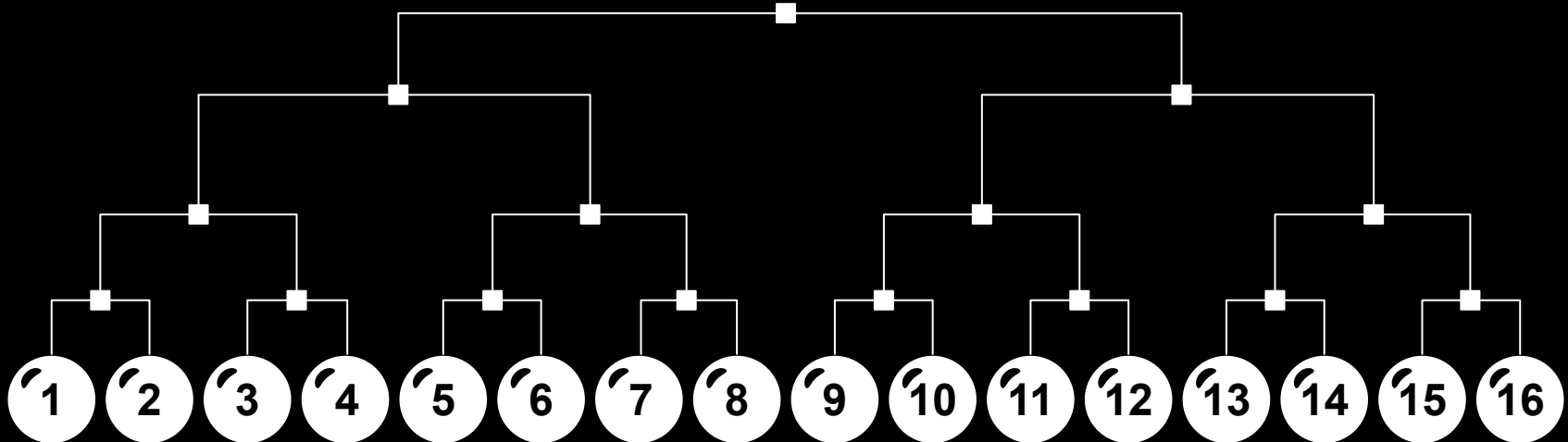
~~N = 2~~

N = 1



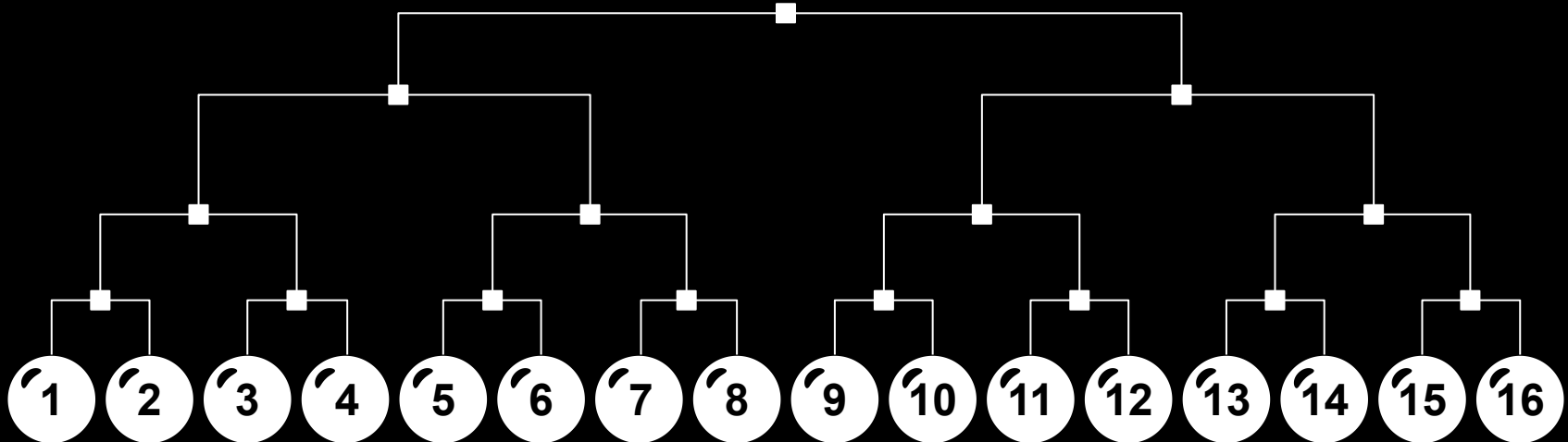
information = reduced uncertainty
uncertainty is measured with the logarithm of N

$$H = \log_2(N)$$

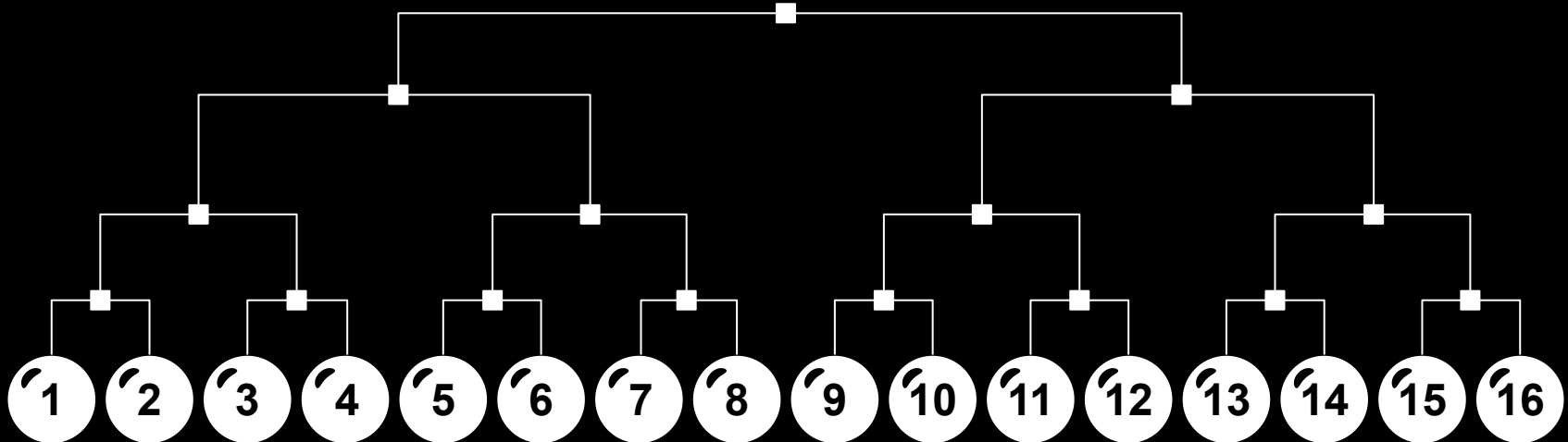


or: how often can we cut the remaining possibilities in half?

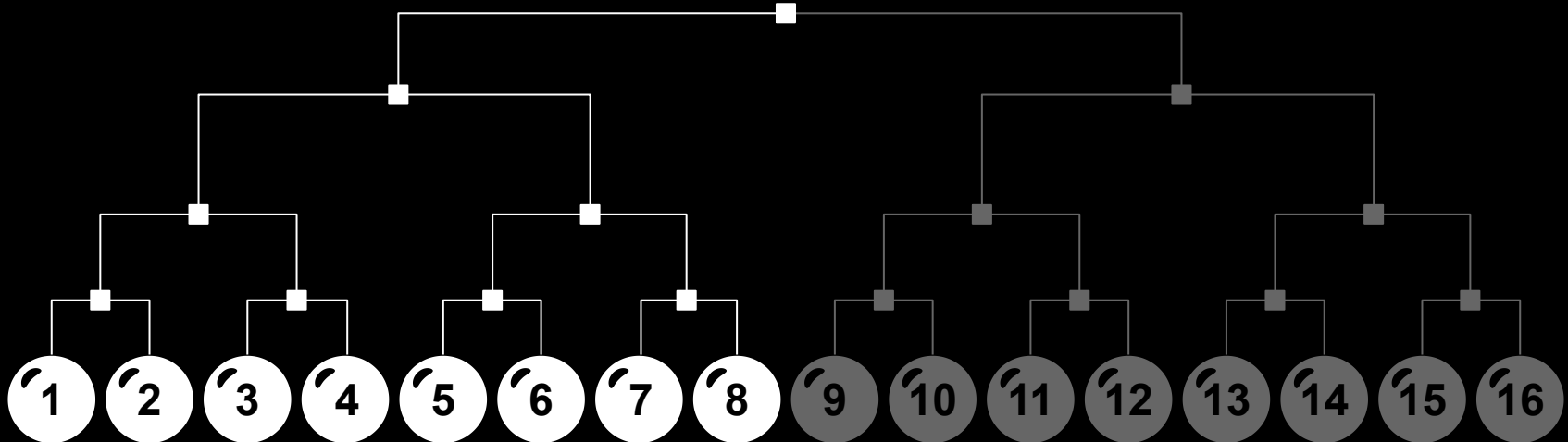
$$H = \log_2(N)$$



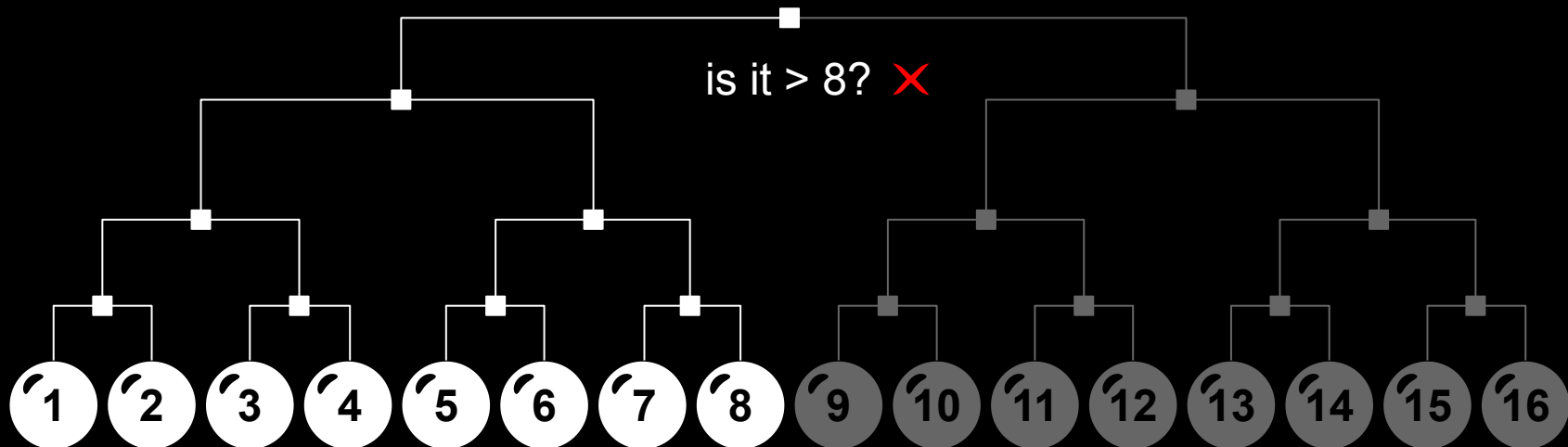
$$H_0 = \log_2(16) = 4$$



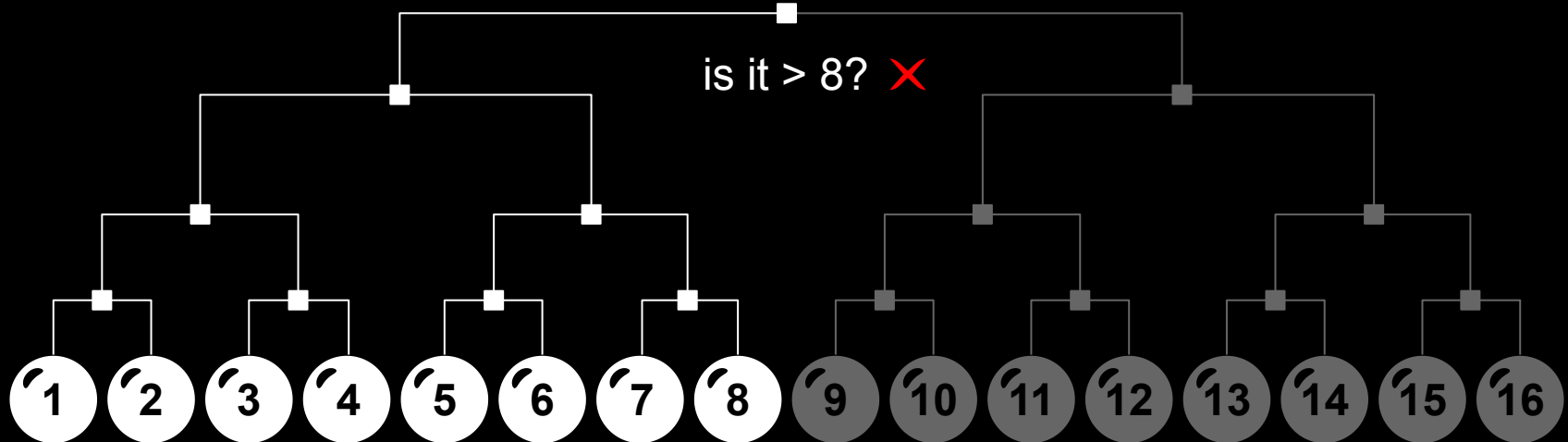
$$H_1 = \log_2(8) = 3$$



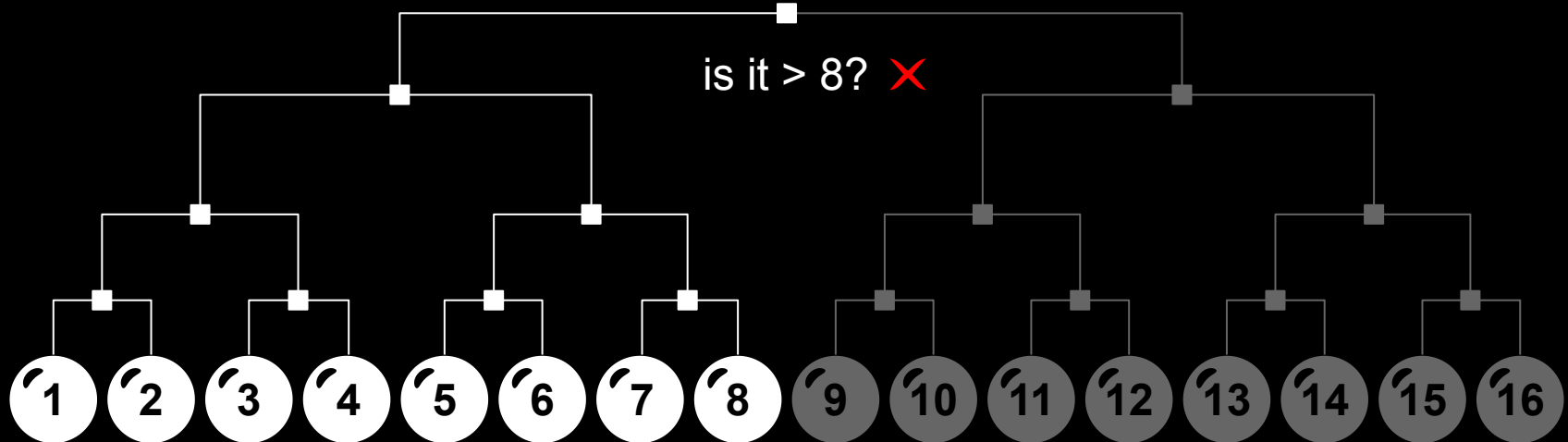
$$I = H_0 - H_1$$



$$I = \log_2(16) - \log_2(8)$$



$$I = 4 - 3 = 1$$



uncertainty and information are
measured in **bits**

how many yes/no questions to reduce
uncertainty to zero?

$$H = 0 = \log_2(1)$$

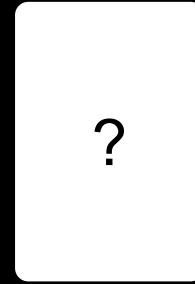
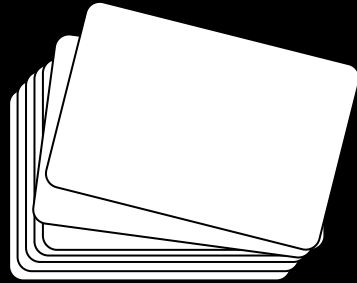
how many yes/no questions to reduce
uncertainty to zero?

$$H = 0 = \log_2(1)$$





















































$$H = \log_2(N)$$

poker

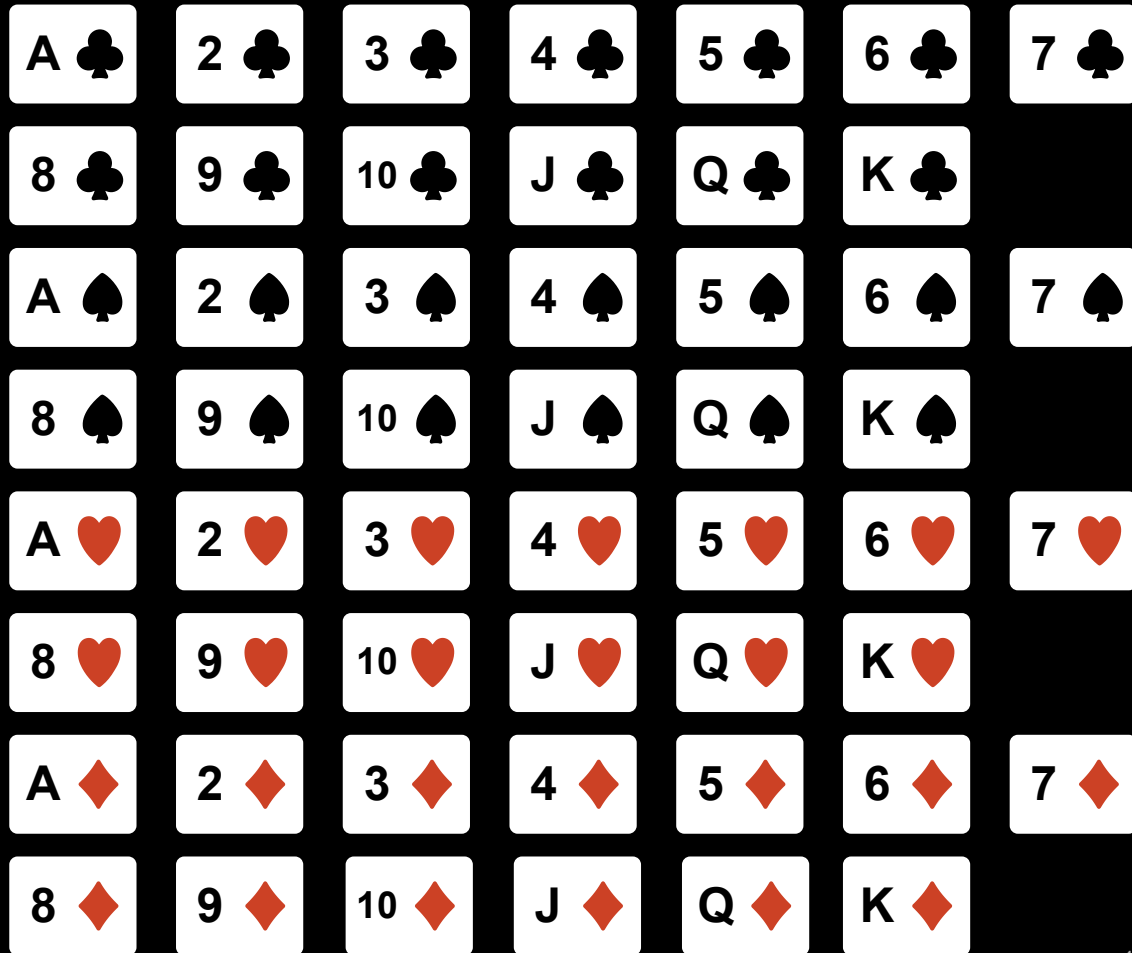
which card am I holding?



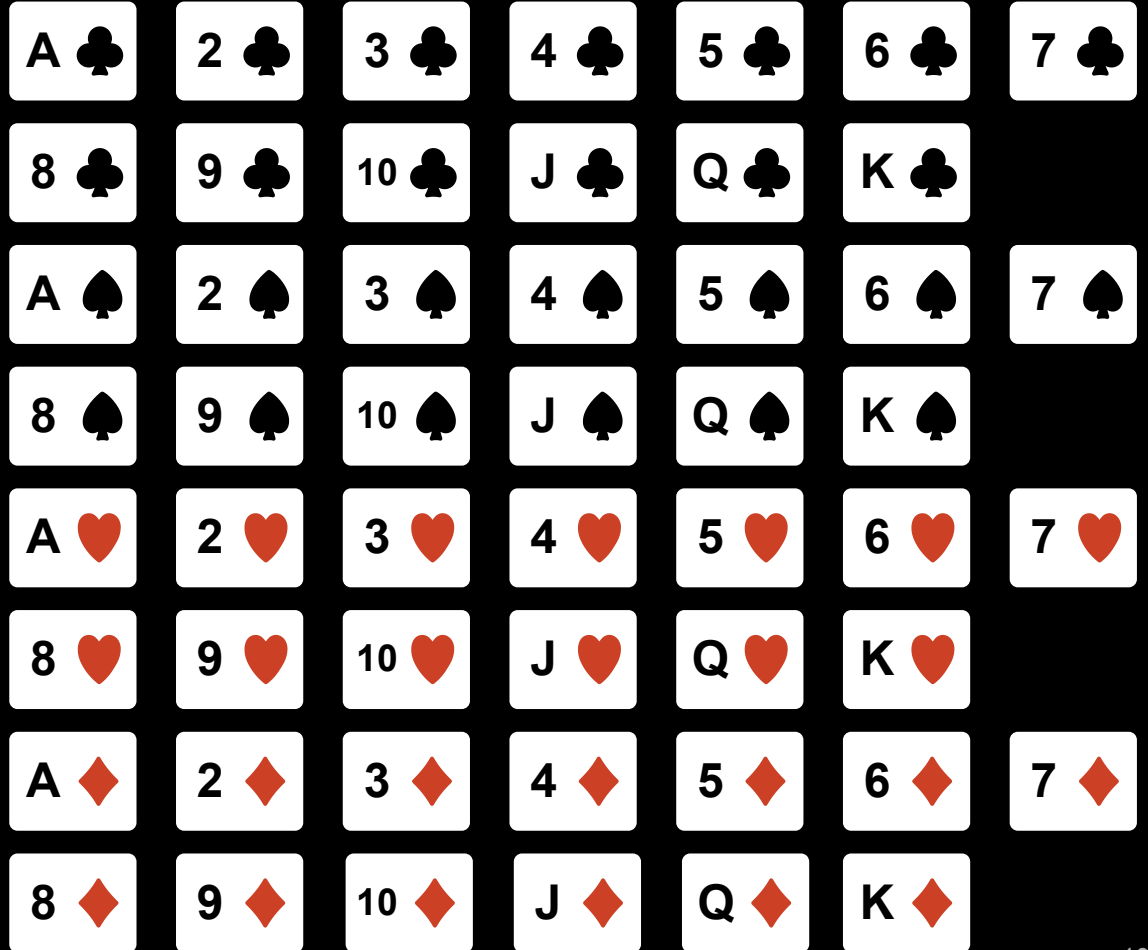
52 card poker deck

A 	2 	3 	4 	5 	6 	7 
8 	9 	10 	J 	Q 	K 	
A 	2 	3 	4 	5 	6 	7 
8 	9 	10 	J 	Q 	K 	
A 	2 	3 	4 	5 	6 	7 
8 	9 	10 	J 	Q 	K 	
A 	2 	3 	4 	5 	6 	7 
8 	9 	10 	J 	Q 	K 	

52 possible cards

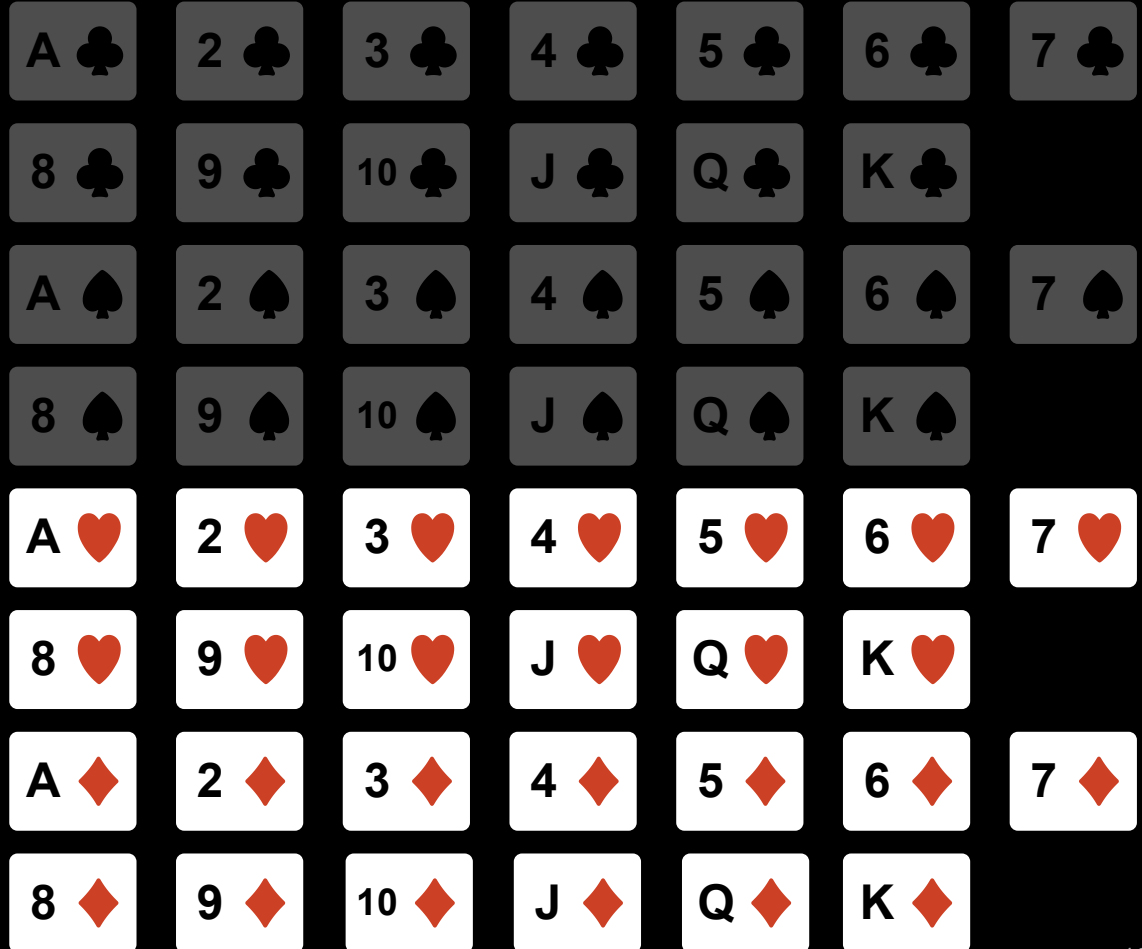


is the card black?



is the card black?

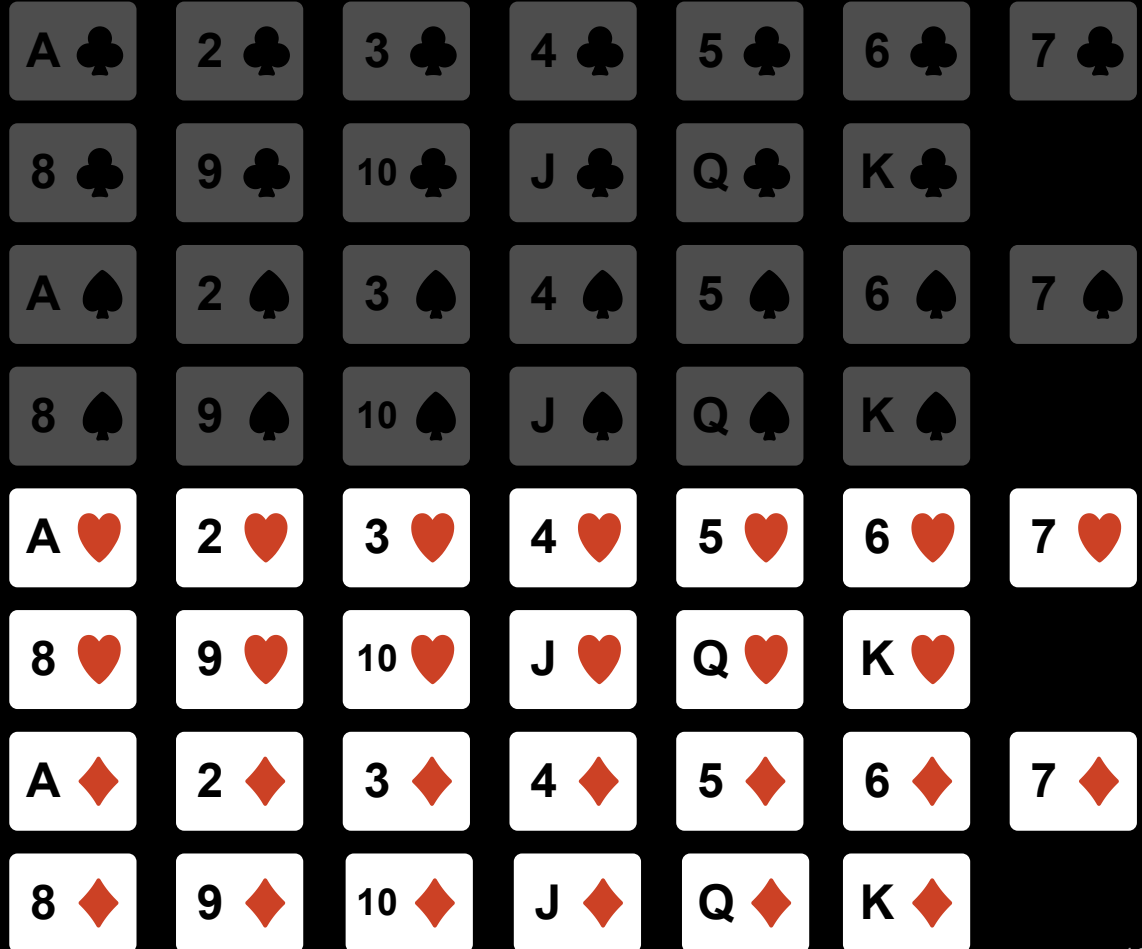
no



is the card black?

no

is it hearts?

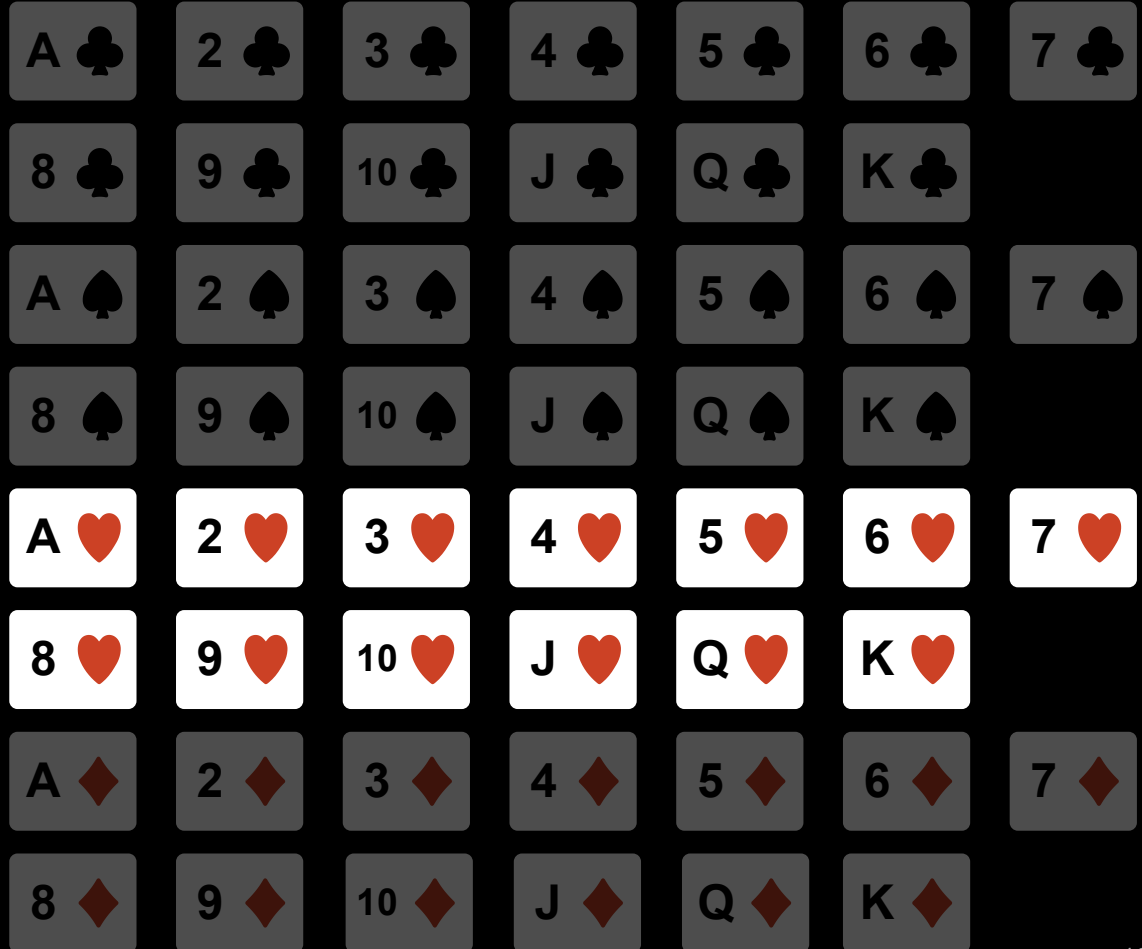


is the card black?

no

is it hearts?

yes



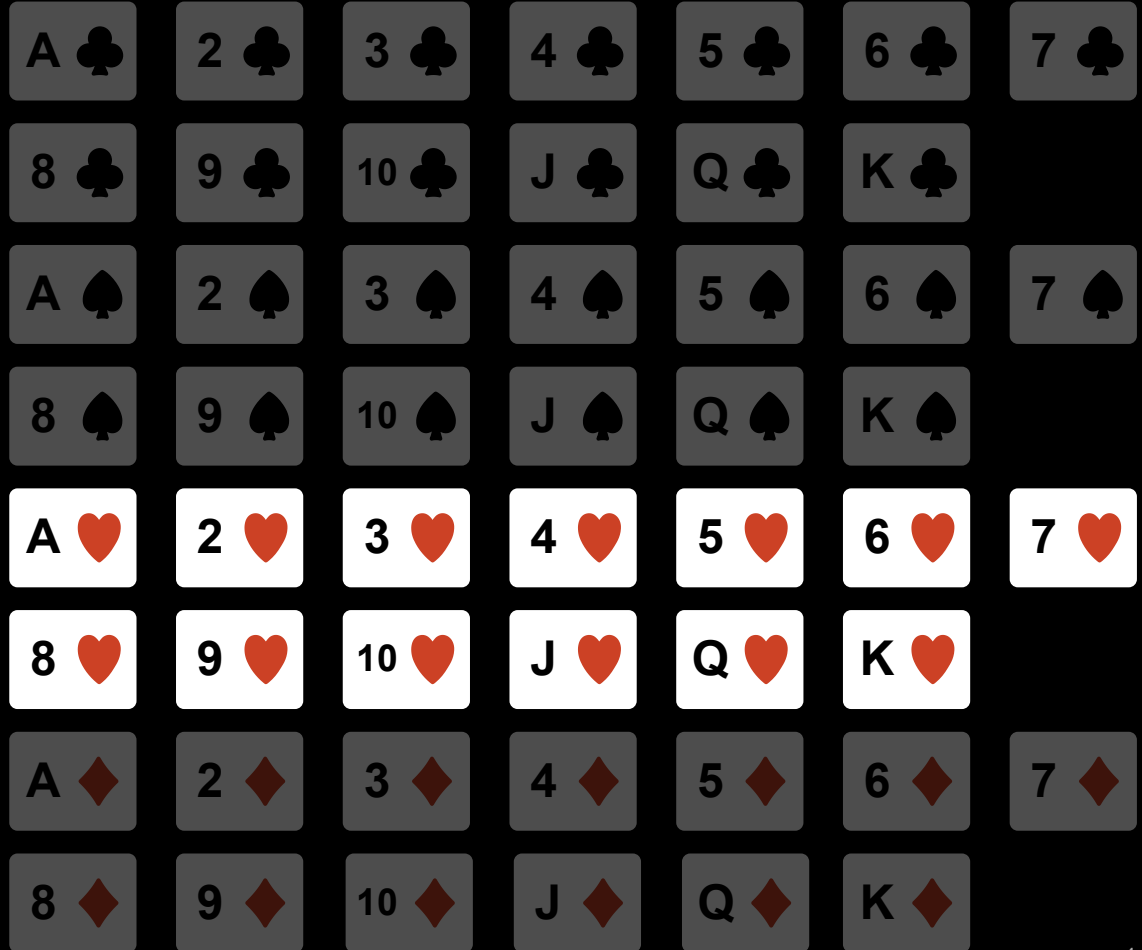
is the card black?

no

is it hearts?

yes

is it 8 or above?



is the card black?

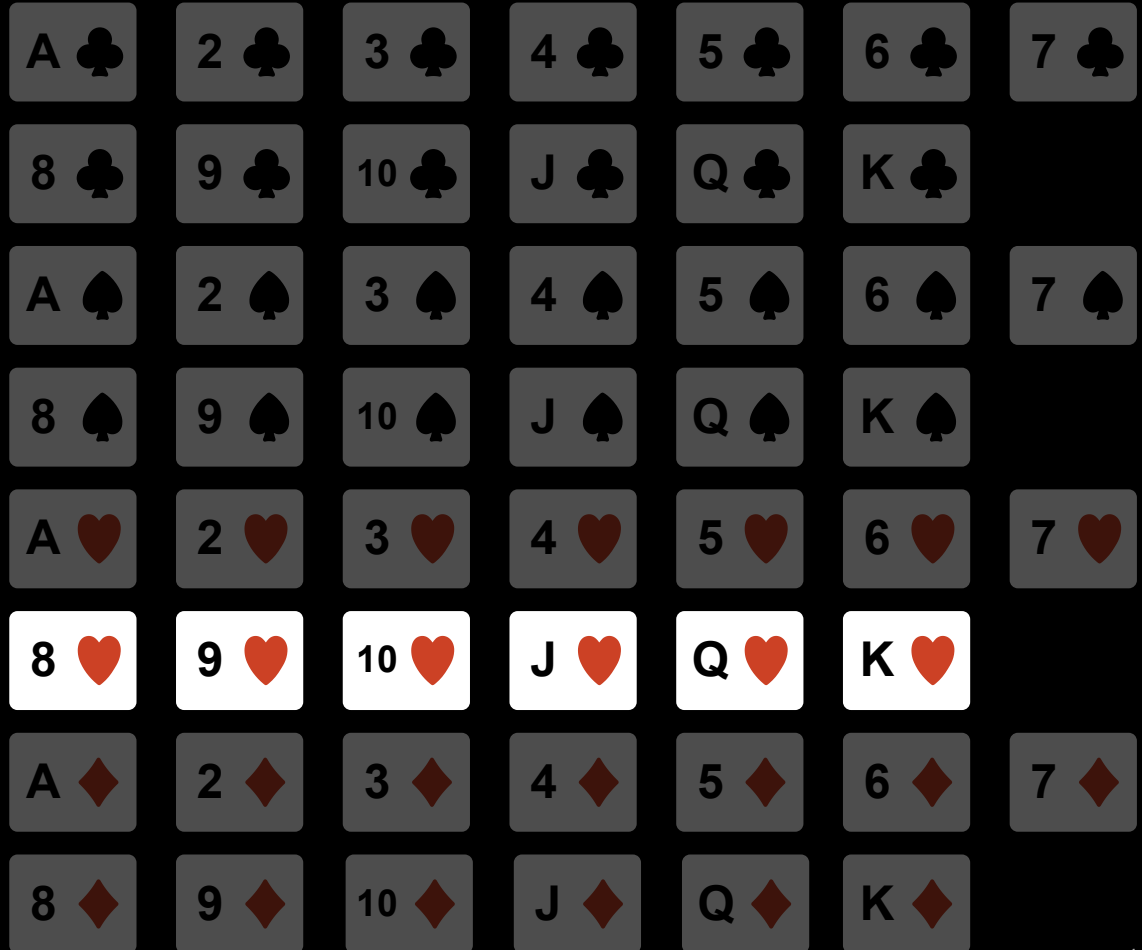
no

is it hearts?

yes

is it 8 or above?

yes



is the card black?

no

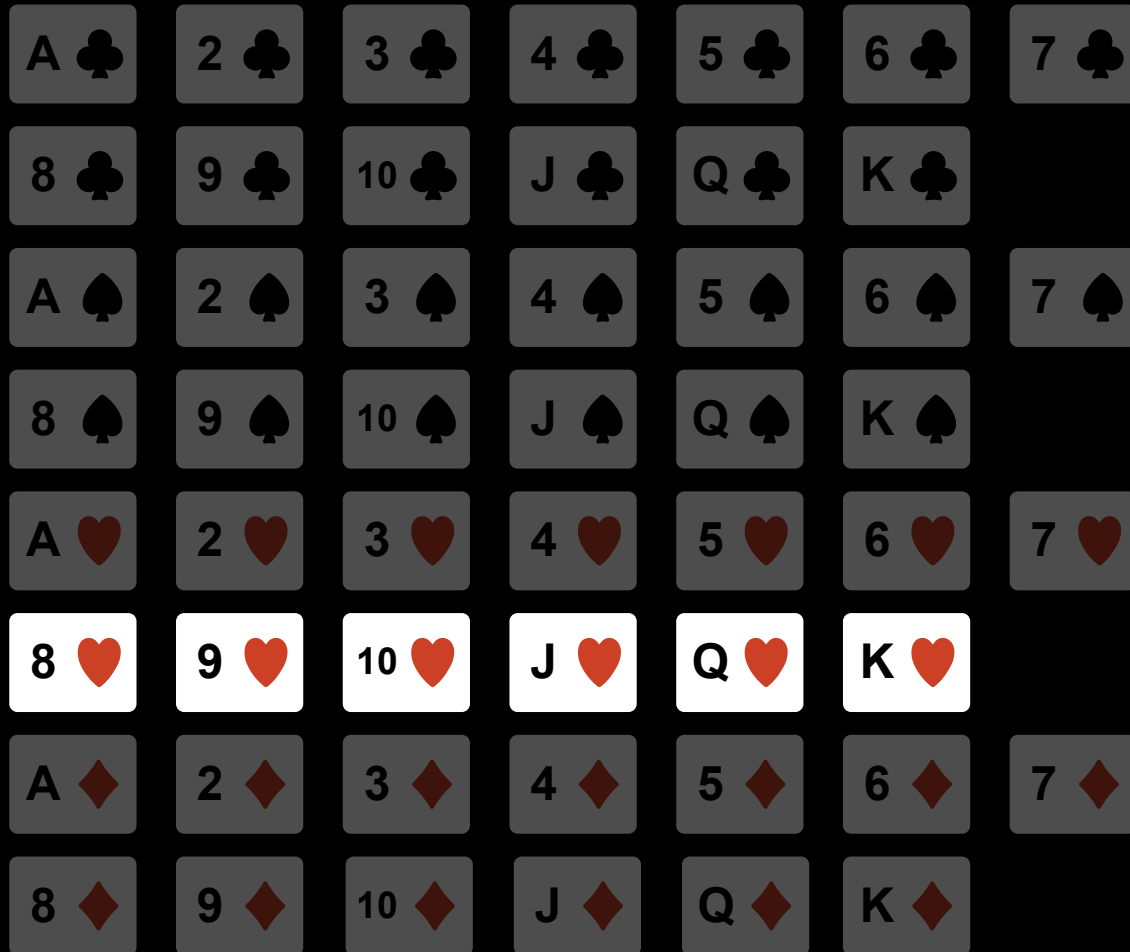
is it hearts?

yes

is it 8 or above?

yes

is it jack or above?



is the card black?

no



is it hearts?

yes



is it 8 or above?

yes



is it jack or above?

yes



is the card black?

no



is it hearts?

yes



is it 8 or above?

yes



is it jack or above?

yes



is it queen or above?



is the card black?

no



is it hearts?

yes



is it 8 or above?

yes



is it jack or above?

yes



is it queen or above?

yes



is the card black?

no



is it hearts?

yes



is it 8 or above?

yes



is it jack or above?

yes



is it queen or above?

yes



is it king?



is the card black?

no



is it hearts?

yes



is it 8 or above?

yes



is it jack or above?

yes



is it queen or above?

yes



is it king?

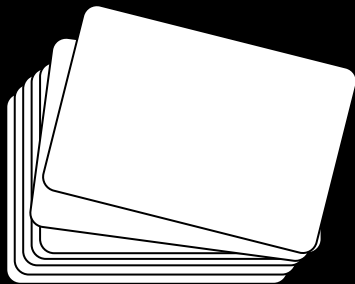
no



with 6 questions
from 52 to 1

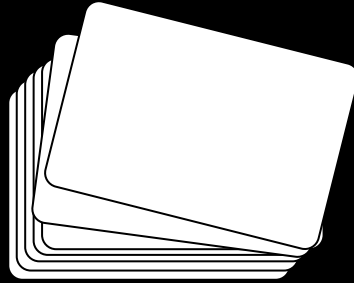
A ♣	2 ♣	3 ♣	4 ♣	5 ♣	6 ♣	7 ♣
8 ♣	9 ♣	10 ♣	J ♣	Q ♣	K ♣	
A ♠	2 ♠	3 ♠	4 ♠	5 ♠	6 ♠	7 ♠
8 ♠	9 ♠	10 ♠	J ♠	Q ♠	K ♠	
A ♥	2 ♥	3 ♥	4 ♥	5 ♥	6 ♥	7 ♥
8 ♥	9 ♥	10 ♥	J ♥	Q ♥	K ♥	
A ♦	2 ♦	3 ♦	4 ♦	5 ♦	6 ♦	7 ♦
8 ♦	9 ♦	10 ♦	J ♦	Q ♦	K ♦	

uncertainty with $N = 52$ possibilities?

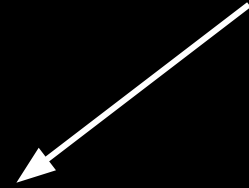


$$H = \log_2(52) \approx 5.7$$

uncertainty with $N = 52$ possibilities?



average # of yes/no
questions



$$H = \log_2(52) \approx 5.7$$

one bit of information with each answer...

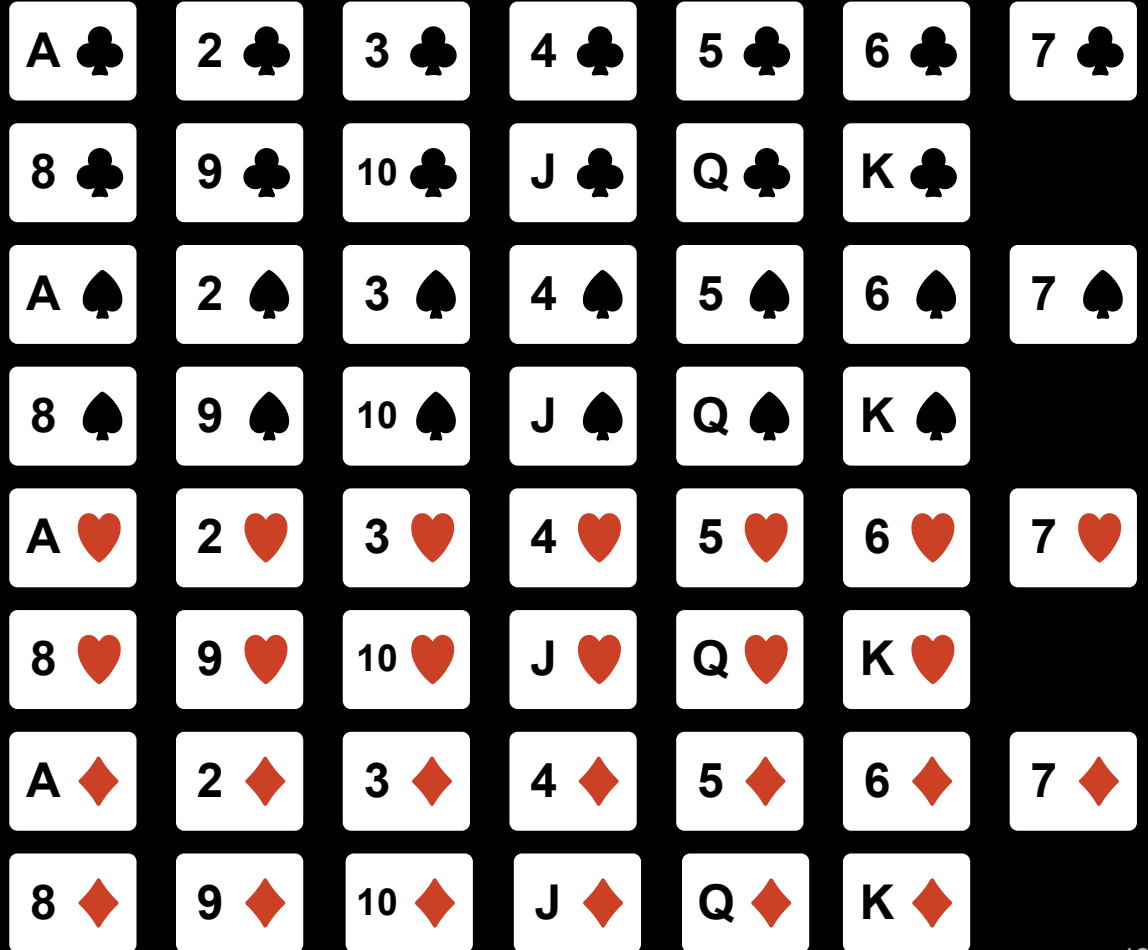
$$\log_2(52) - \log_2(26) = 1$$

one bit of information with each answer...

$$\log_2(52) - \log_2(26) = 1$$

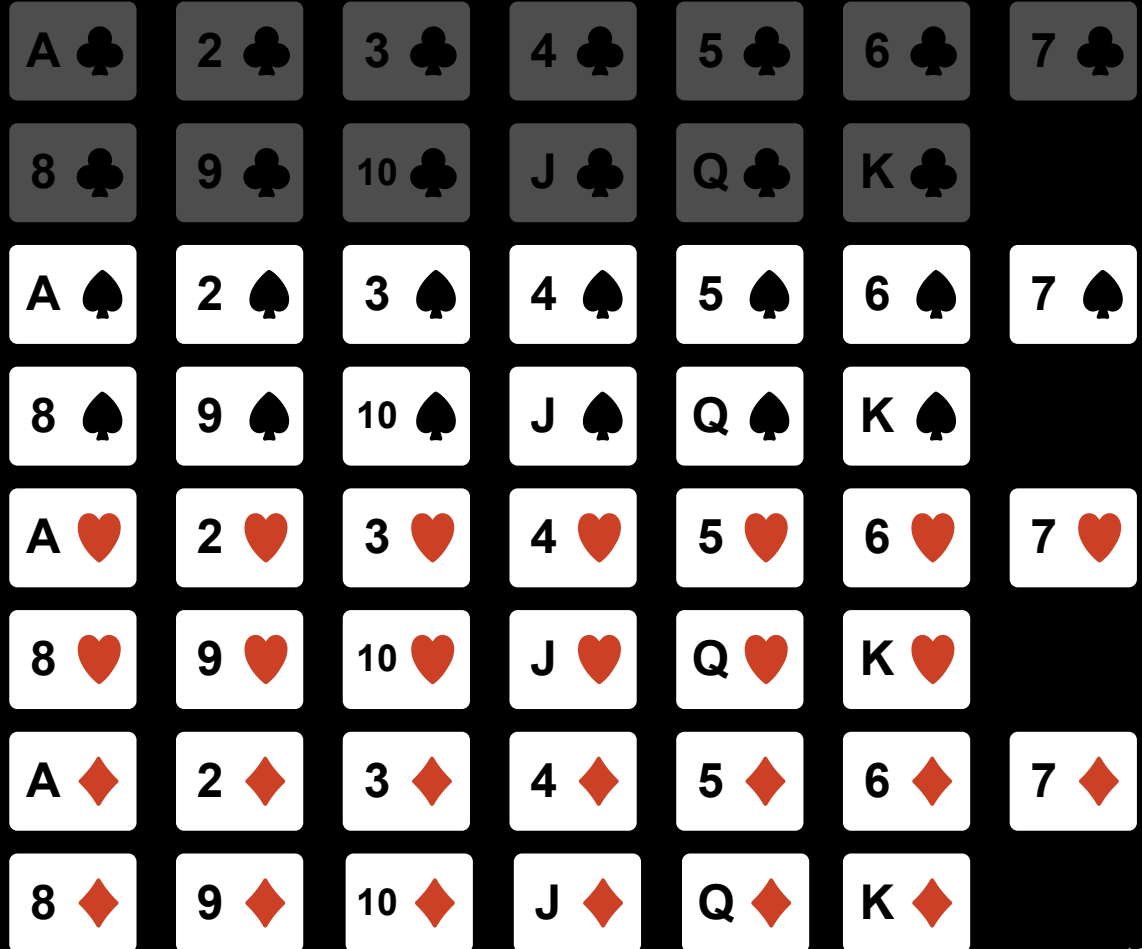
...that cuts the remaining options in half

is it a spades card?



is it a spades card?

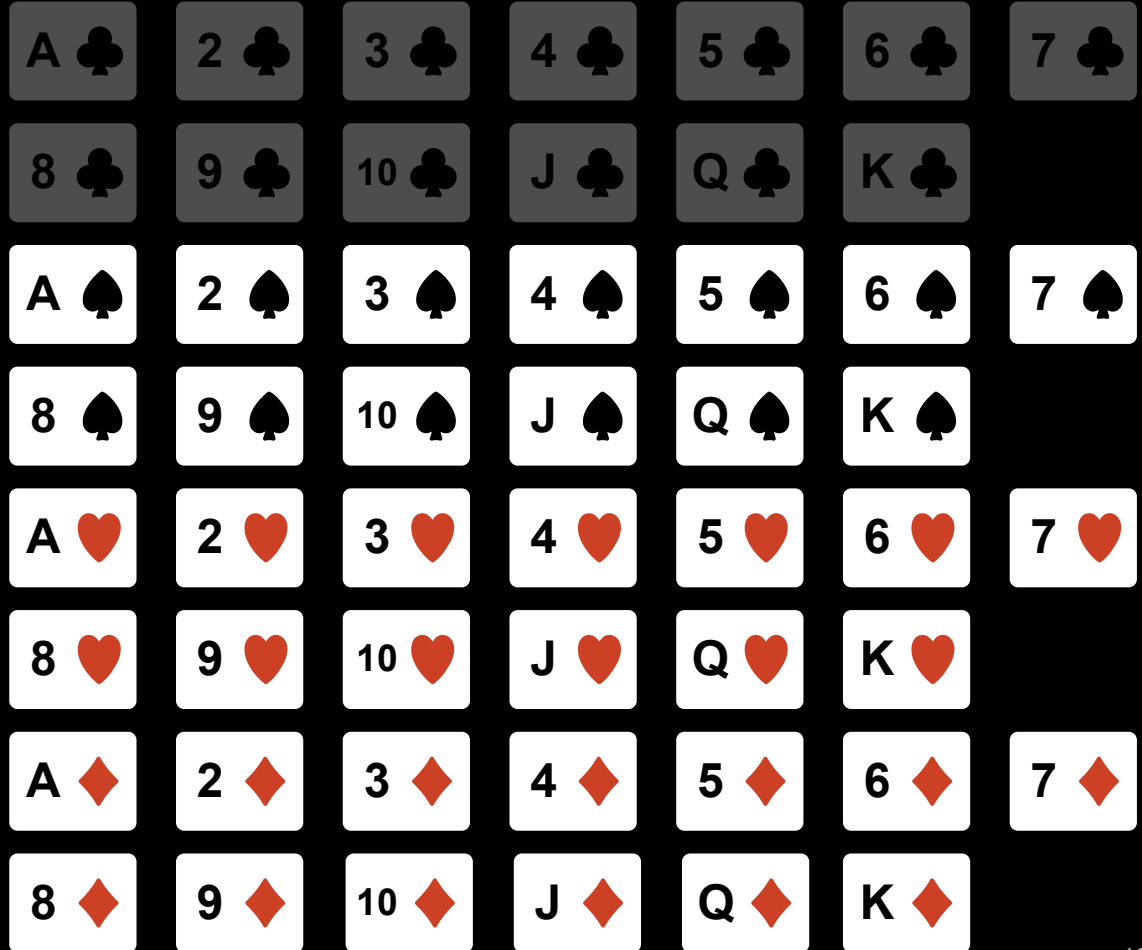
no



is it a spades card?

no

how much information?



is it a spades card?

no



how much information?



$$H_0 = \log_2(52) \approx 5.7$$



$$H_1 = \log_2(39) \approx 5.29$$



is it a spades card?

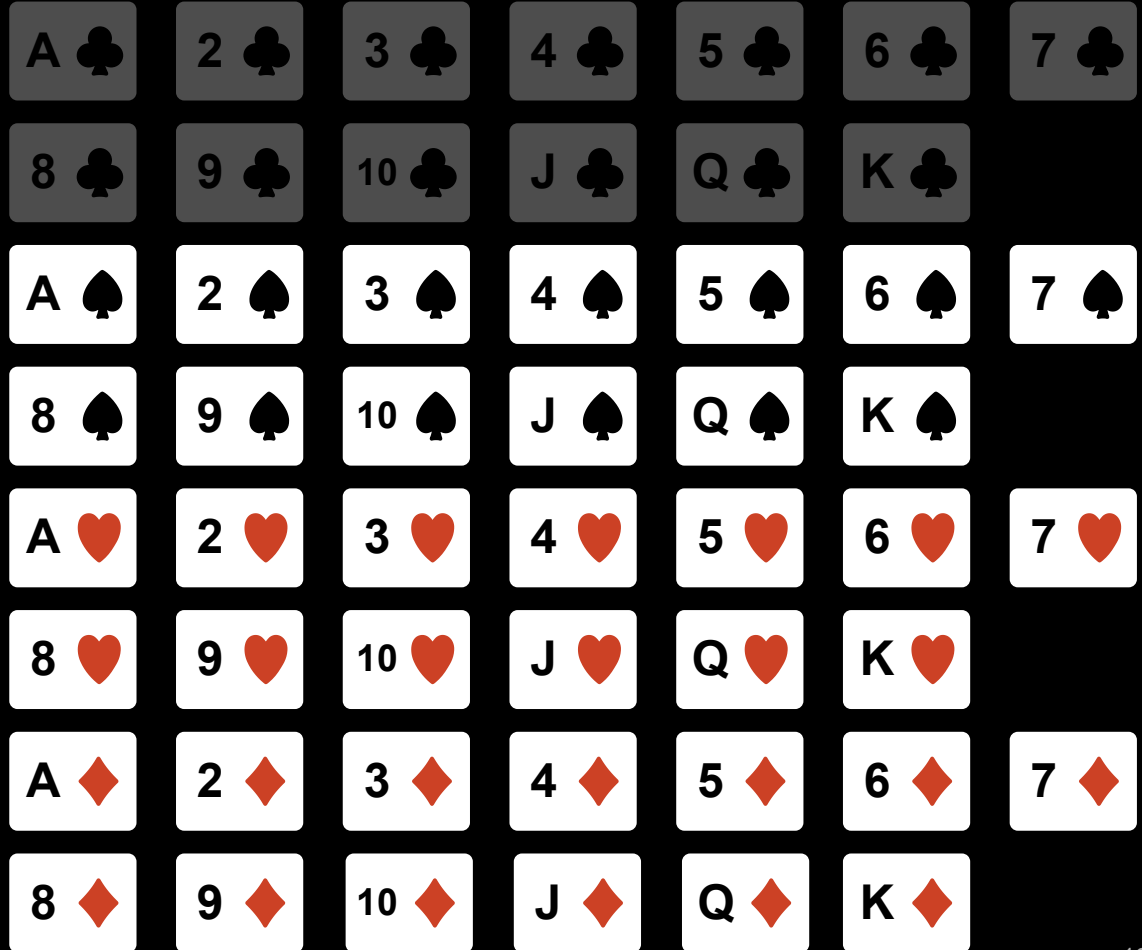
no

how much information?

$$H_0 = \log_2(52) \approx 5.7$$

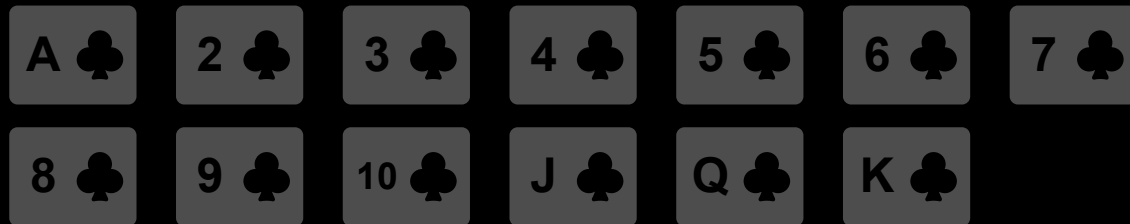
$$H_1 = \log_2(39) \approx 5.29$$

$$H_0 - H_1 \approx 0.41$$



is it a spades card?

no



how much information?



$$H_0 = \log_2(52) \approx 5.7$$



$$H_1 = \log_2(39) \approx 5.29$$



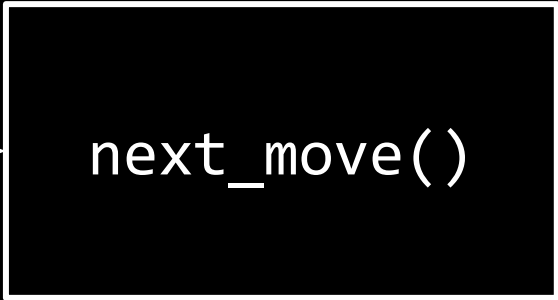
$$H_0 - H_1 \approx 0.41$$



that's less than 1 bit

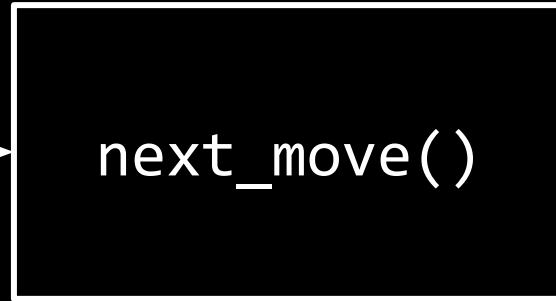
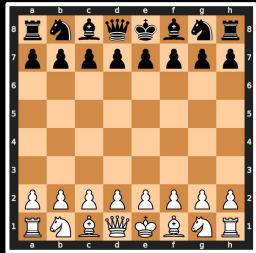


chess

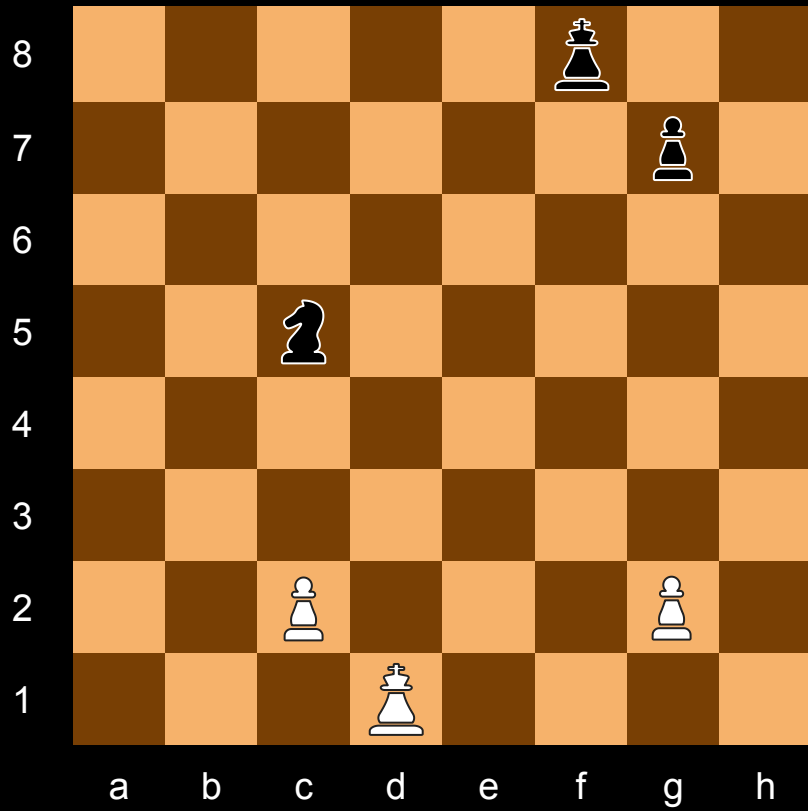


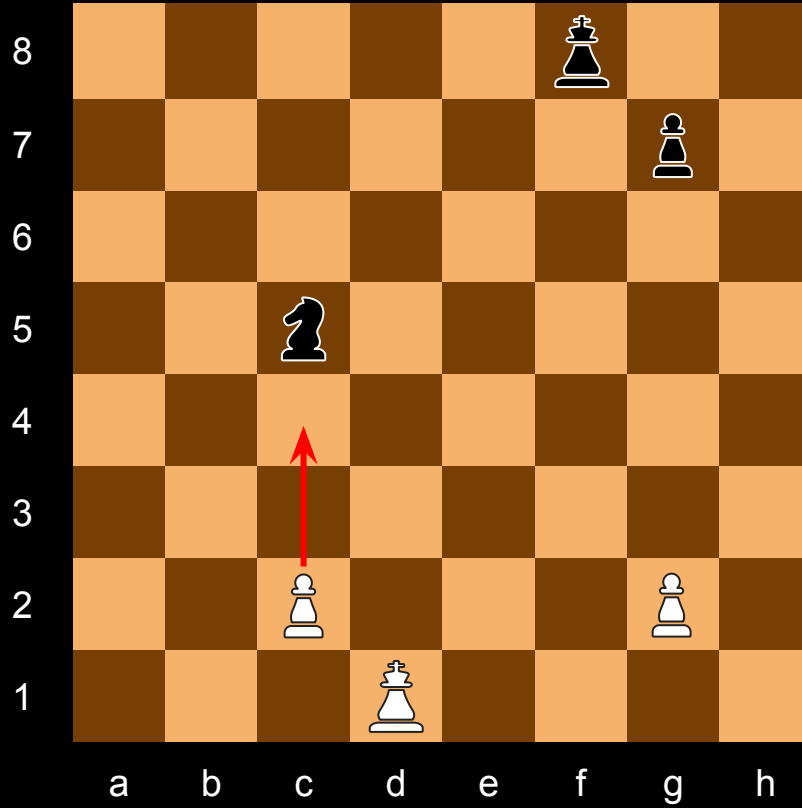
E2 → E4

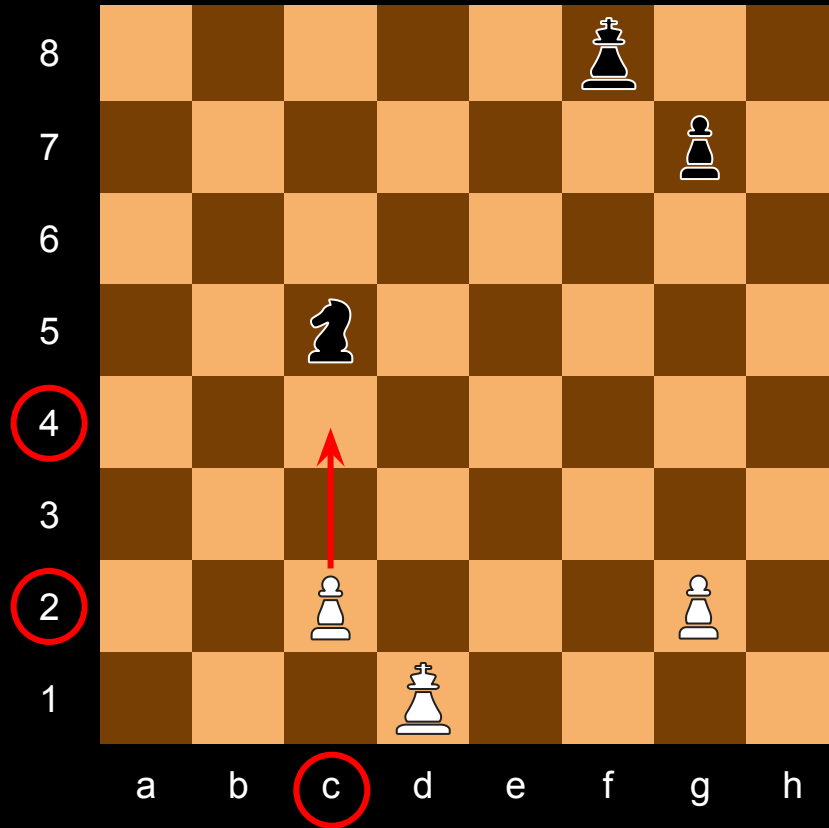
how much information is
one move?



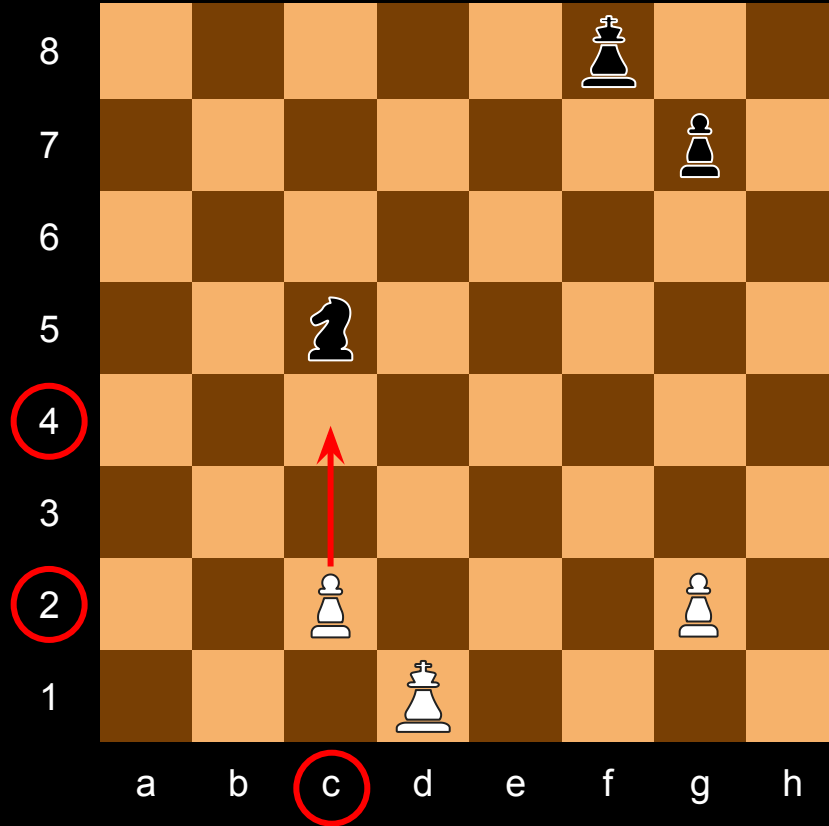
`E2 → E4`



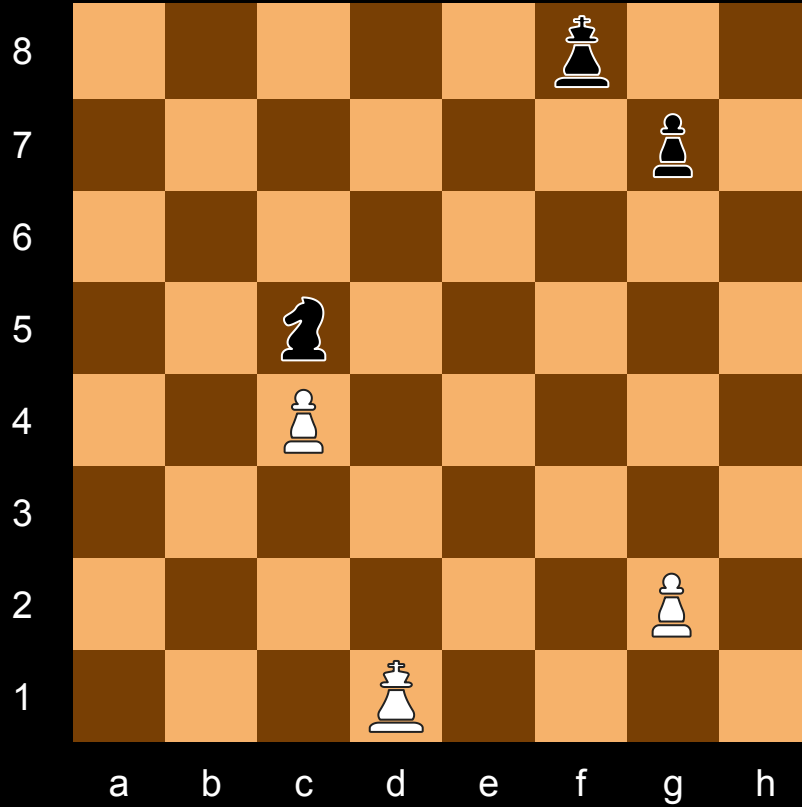




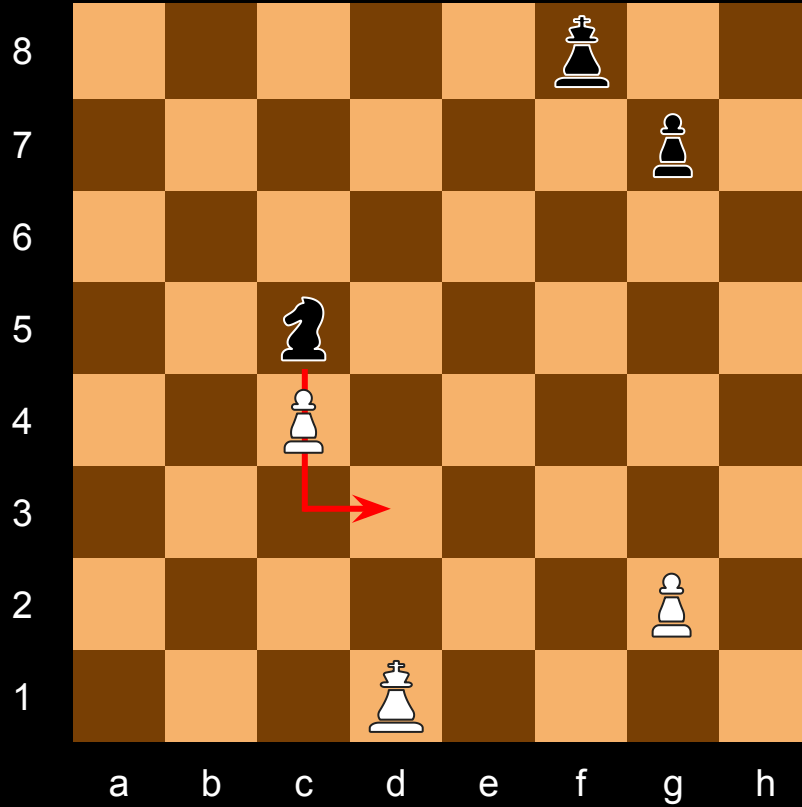
c2 → c4



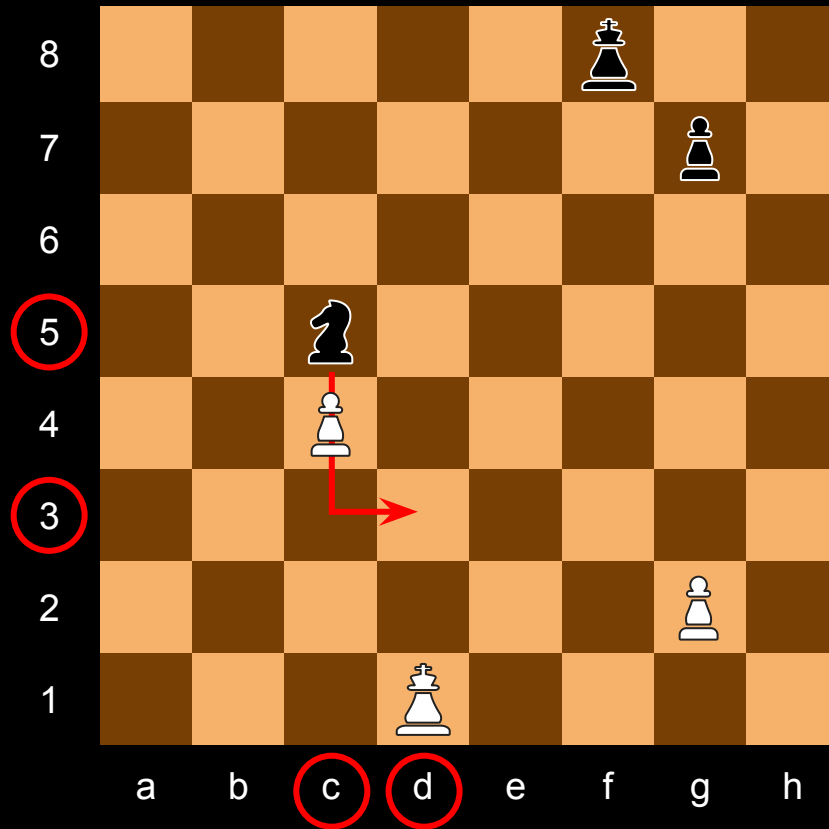
c2 → c4



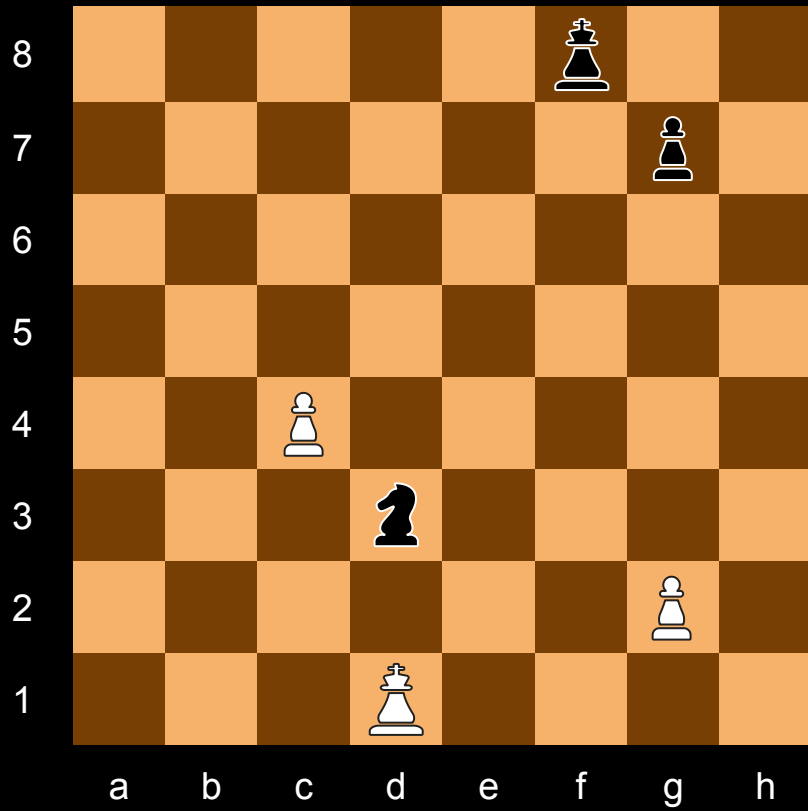
c2 → c4



c2 → c4
c5 → d3



c2 → c4
c5 → d3
...



$$c_2 \rightarrow c_4$$

how many possibilities?

64 fields x 64 fields

how many possibilities?

$$64 \times 64 = 4096$$

possible moves*

*disregarding impossible moves

$$64 \times 64 = 4096$$

$$H = \log_2(4096) = 12$$

$$64 \times 64 = 4096$$

$$H = \log_2(4096) = 12$$

one chess move is 12 bits of information

an alternative way to calculate # bits

c 2 c 4

4 digits

c 2 c 4

4 digits

8 possible symbols per digit

c 2 c 4

4 digits

8 possible symbols per digit
how many bits per digit?

c 2 c 4

4 digits

8 possible symbols per digit
how many bits per digit?

$$H_{digit} = \log_2(8) = 3$$

c 2 c 4

4 digits

8 possible symbols per digit

how many bits per digit?

$$H_{digit} = \log_2(8) = 3$$

$$H_{move} = \log_2(8) \times 4 = 12$$

$$H_{avg} = \log_2(S) \times n$$

S : number of possible symbols

n : number of digits in our message

$$H_{max} = \lceil \log_2(S) \rceil \times n$$

when calculating bits for storage, we must
always consider the worst case

digits and # symbols

{A}

— —

{A}

A A

{A, B}

— —

{A, B}

AA, AB, BA, BB

{A, B, C}

— —

{A, B, C}

AA, AB, BA, BB,
AC, BC, CA, CB, CC

{A, B, C, D}

— —

{A, B, C, D}

AA, AB, BA, BB, AC, BC, CA, CB,
CC, AD, DA, BD, DB, CD, DC, DD

{A, B, C, D, E}

— —

{A, B, C, D, E}

AA, AB, BA, BB, AC, BC, CA, CB, CC,
AD, DA, BD, DB, CD, DC, DD, AE, EA,
BE, EB, CE, EC, DE, ED, EE

with # digits $n = 2$

symbols

messages

1

1

2

4

3

9

4

16

5

25

with length $n = 2$

symbols

messages

1

1

2

4

3

$f(x)$

9

4

16

5

25



and more digits?

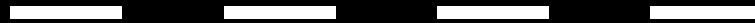
{A, B}

— — —

{A, B}

AAA, AAB, ABA, ABB,
BBB, BBA, BAA, BAB

{A, B}



{A, B}

AAAA, AAAB, AABA, AABB,
ABAA, ABAB, ABBA, ABBB,
BAAA, BAAB, BABA, BABB,
BBAA, BBAB, BBBA, BBBB

with # symbols $S = 2$

digits

messages

1

2

2

4

3

8

4

16

5

32

with # symbols $S = 2$

digits

messages

1

2

2

4

3



8

4

16

5

32

$f(x)$

with # symbols $S = 2$

digits

messages

1

2

2

4

3

8

4

16

5

32

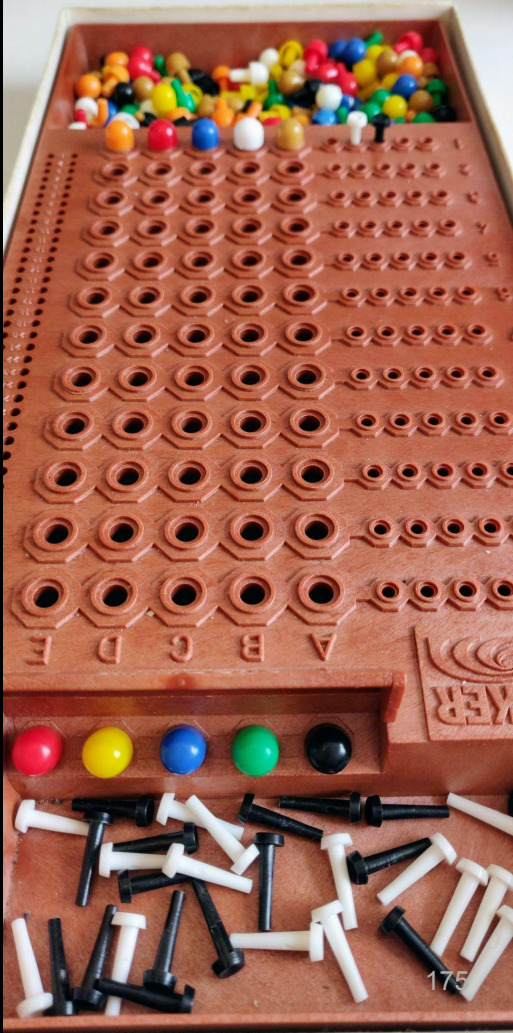
$f(x)$



possible messages with n digits and S symbols

$$N = S^n$$

mastermind



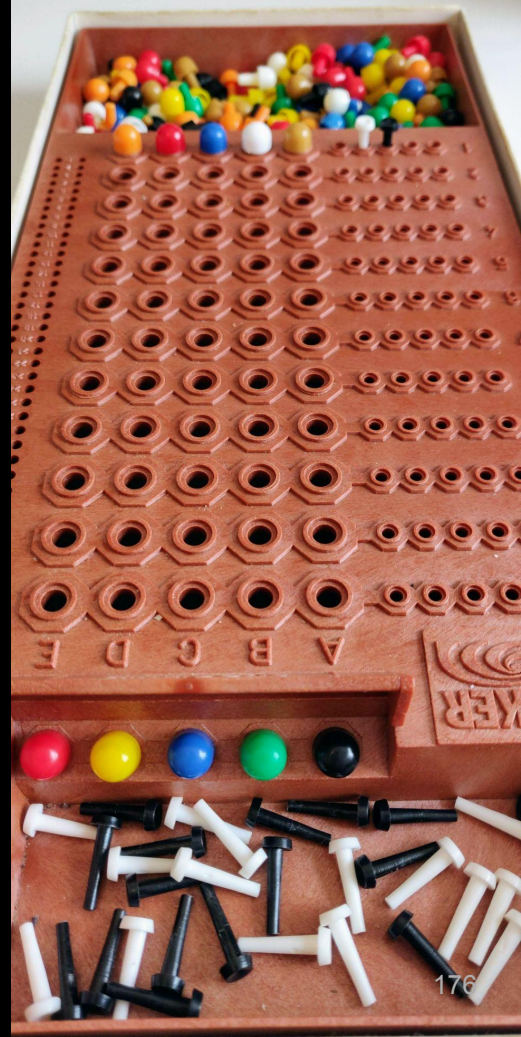
eight colors



five slots



A B C D E



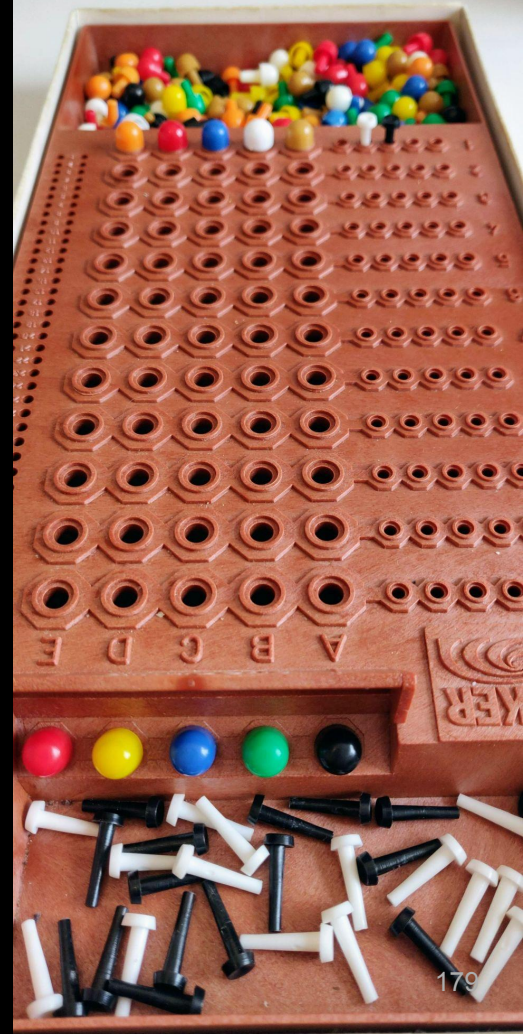
possible permutations

$$N = 5^8 = 390625$$

maximum entropy in bits

$$H_{max} = \log_2 5^8 = 18.575$$

hints reduce uncertainty (entropy)



first guess

opponent's hints



A

B

C

D

E

first guess

opponent's hints

correct



A

B

C

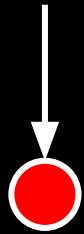
D

E

first guess

opponent's hints

correct



A



B



C



D



E

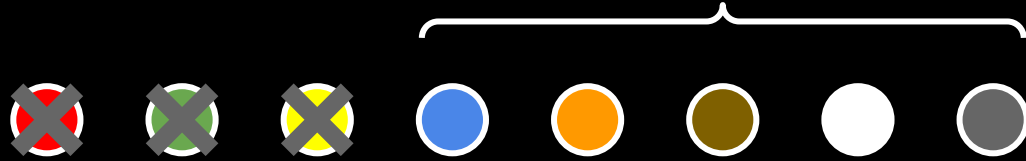
wrong position



how much information did we get?



colors left



slots left



new possible permutations?

$$N = 4^8 = 65536$$

reduced entropy in bits?

$$H = \log_2 4^8 = 16$$

COUNTING

1

2

3

1

2

3

10^2

10^1

10^0

1 2 3

10^2

10^1

10^0

$$= 1 \times 10^2 + 2 \times 10^1 + 3 \times 10^0$$

$$= 1 \times 100 + 2 \times 10 + 3 \times 1$$

$$= 123$$

4

1

2

3

?

10^2

10^1

10^0

4 1 2 3

?

10^2

10^1

10^0

$$= 4 \times 10^3 + 1 \times 10^2 + 2 \times 10^1 + 3 \times 10^0$$

4 1 2 3

?

10^2

10^1

10^0

$$= 4 \times 10^3 + 1 \times 10^2 + 2 \times 10^1 + 3 \times 10^0$$

$$= 4 \times 1000 + 1 \times 100 + 2 \times 10 + 3 \times 1$$

4 1 2 3

?

10^2

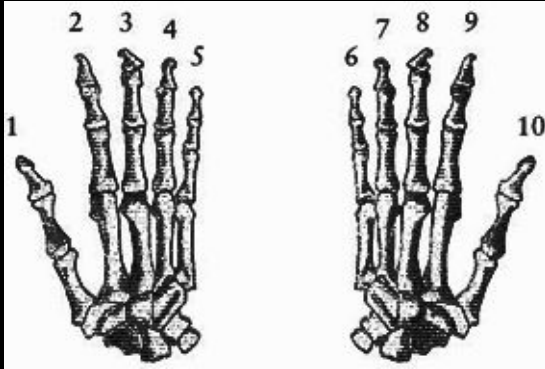
10^1

10^0

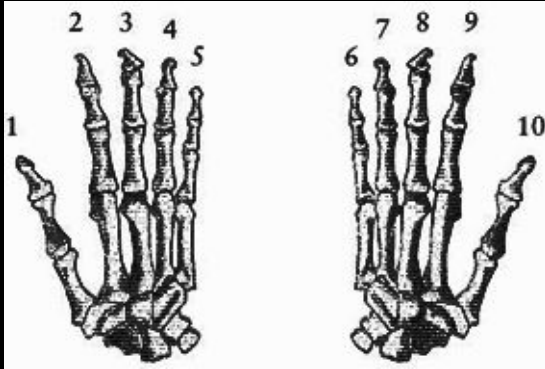
$$= 4 \times 10^3 + 1 \times 10^2 + 2 \times 10^1 + 3 \times 10^0$$

$$= 4 \times 1000 + 1 \times 100 + 2 \times 10 + 3 \times 1$$

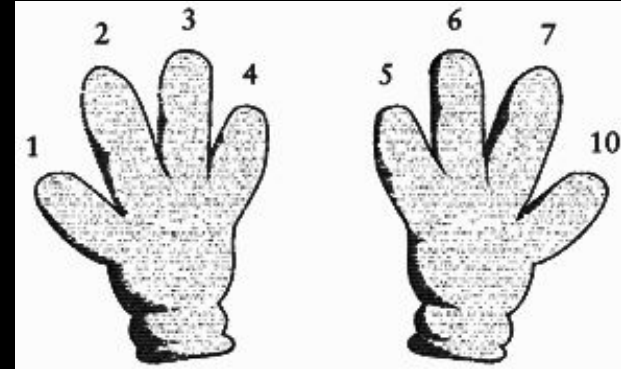
$$= 4123$$



human hand



human hand



cartoon character's hand

1

2

3

(octal)

1

2

3

(octal)

8^2

8^1

8^0

1 2 3

(octal)

8^2

8^1

8^0

$$= 1 \times 8^2 + 2 \times 8^1 + 3 \times 8^0$$

1 2 3

(octal)

8^2

8^1

8^0

$$= 1 \times 8^2 + 2 \times 8^1 + 3 \times 8^0$$

$$= 1 \times 64 + 2 \times 8 + 3 \times 1$$

1

2

3

(octal)

8^2

8^1

8^0

$$= 1 \times 8^2 + 2 \times 8^1 + 3 \times 8^0$$

$$= 1 \times 64 + 2 \times 8 + 3 \times 1$$

$$= 83 \text{ (decimal)}$$

decimal

octal

8



?

decimal

octal

?



7

decimal

octal

16



?

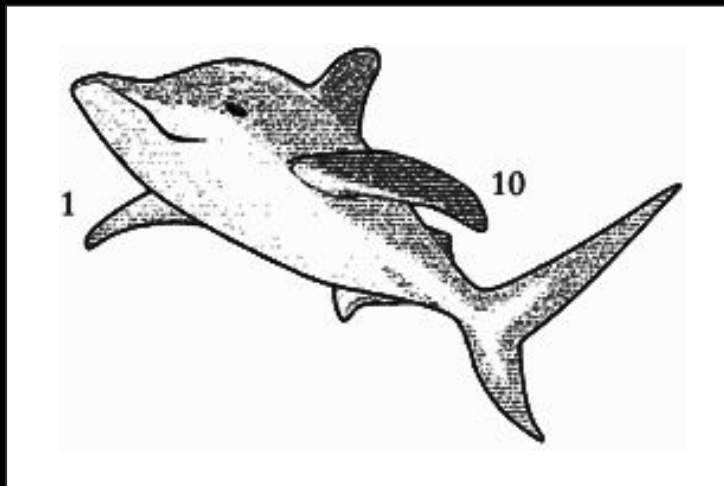
decimal

octal

?



100



what now?

0, 1, ...

0, 1, 10, ...

0, 1, 10, 11, ...

0, 1, 10, 11, 100, ...

0, 1, 10, 11, 100, 101, ...

0, 1, 10, 11, 100, 101, 110

1 1 1 0

(binary)

1

1

0

(binary)

2^2

2^1

2^0

1 1 0

(binary)

2^2

2^1

2^0

$$= 1 \times 2^2 + 1 \times 2^1 + 0 \times 2^0$$

1 1 0

(binary)

2^2

2^1

2^0

$$= 1 \times 2^2 + 1 \times 2^1 + 0 \times 2^0$$

$$= 1 \times 4 + 1 \times 2 + 0 \times 1$$

1 1 0

(binary)

2^2

2^1

2^0

$$= 1 \times 2^2 + 1 \times 2^1 + 0 \times 2^0$$

$$= 1 \times 4 + 1 \times 2 + 0 \times 1$$

$$= 6 \text{ (decimal)}$$

2 3 4 5 6

0, 1, 10, 11, 100, 101, 110

place value systems

$$N = d_n * R^{n-1} + \dots + d_2 * R^1 + d_1 * R^0$$

$$d \in \{0, 1, \dots, R-1\}$$

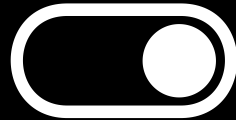
n = number of digits

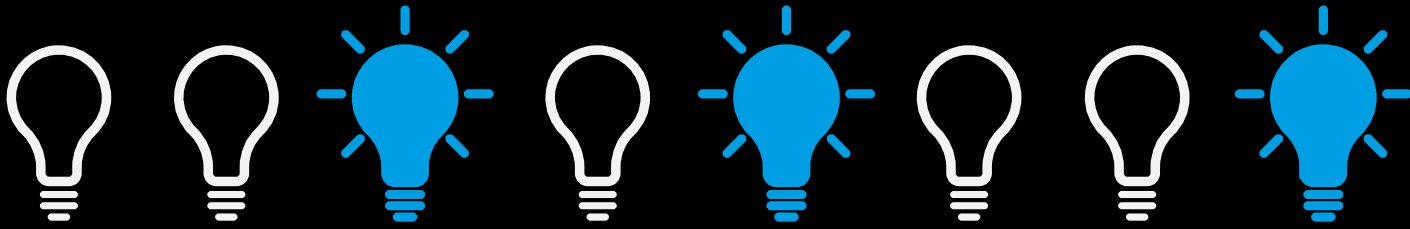
R = base

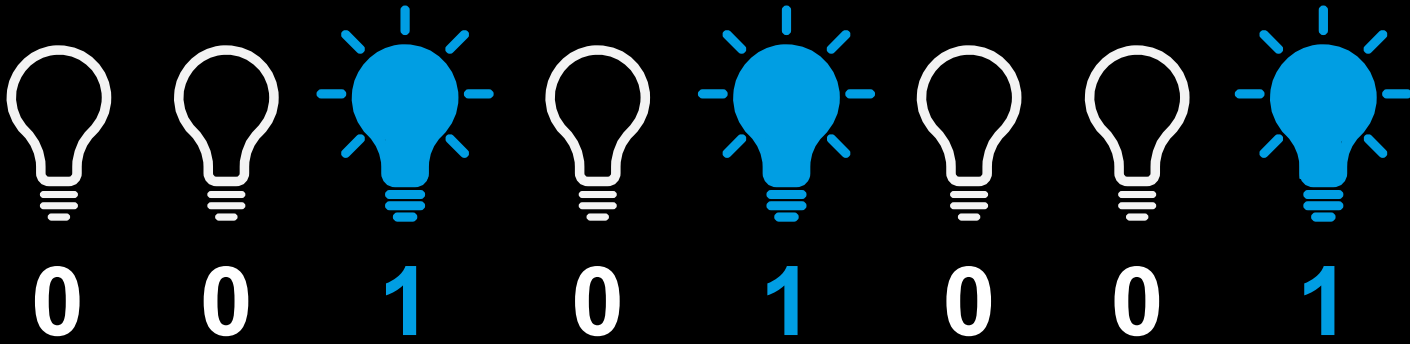
$$R \geq 2$$

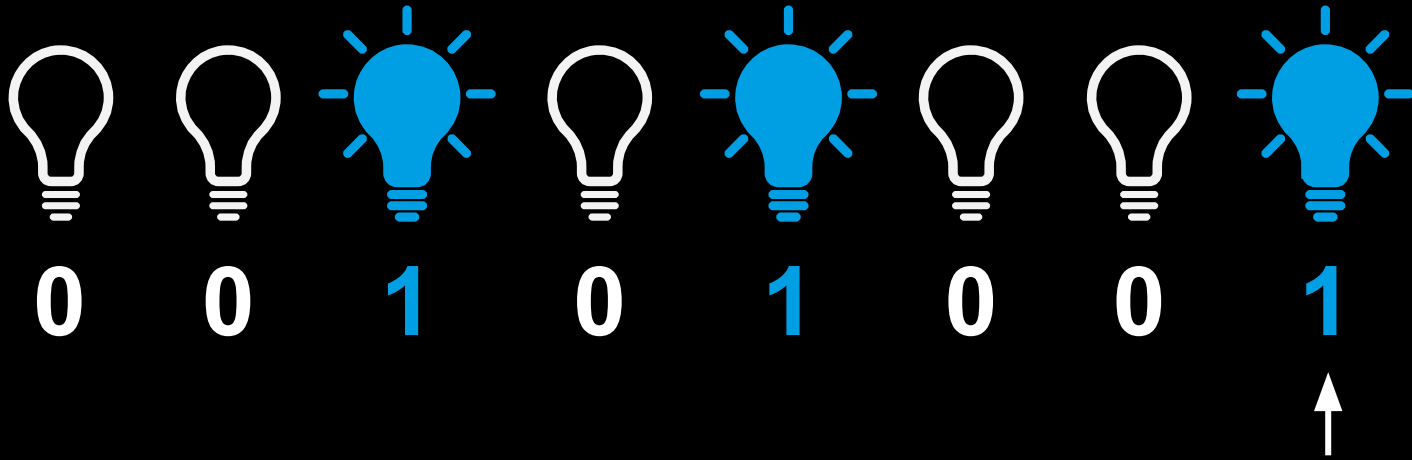
BITS

why do computers think binary?

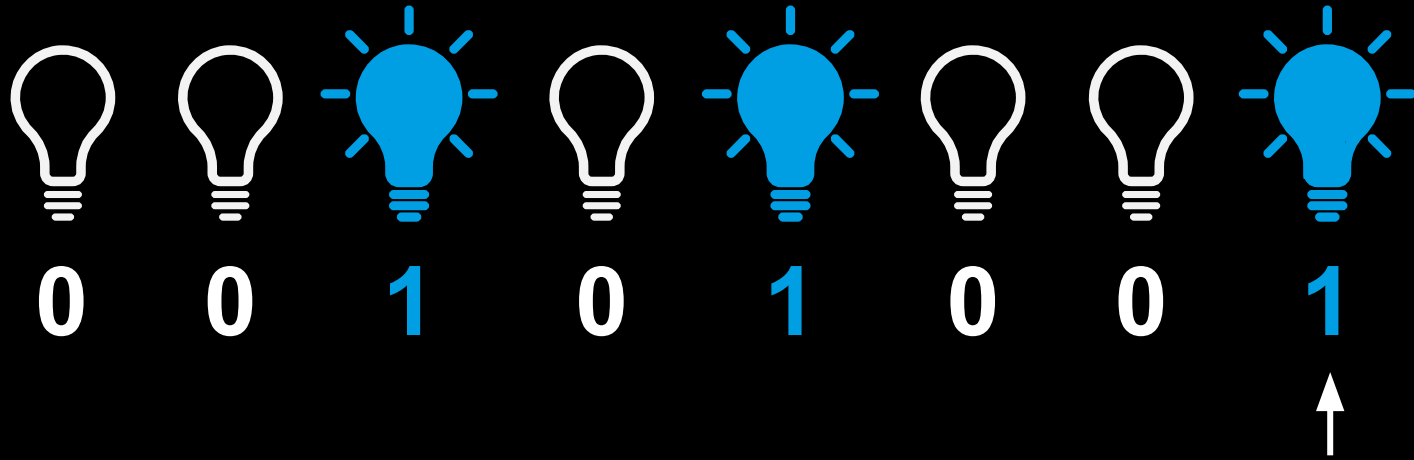








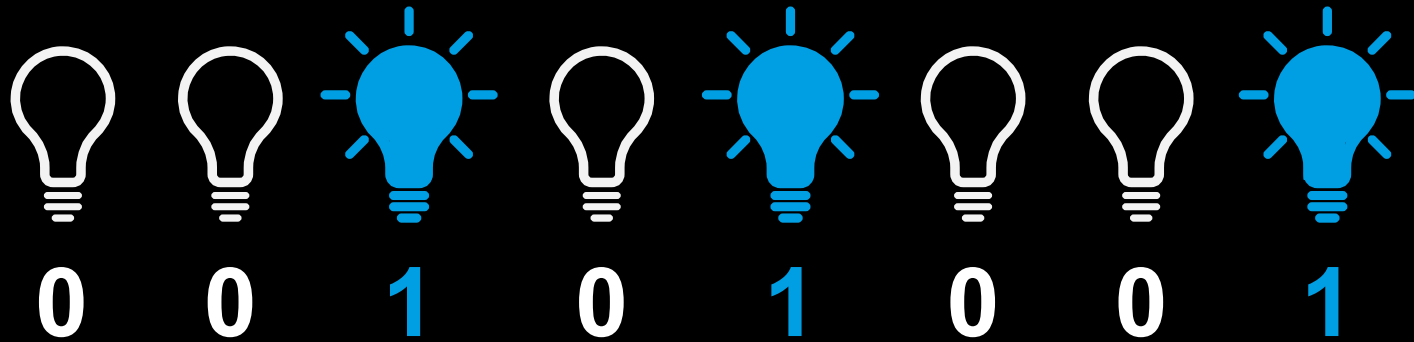
a **bit** (binary digit)



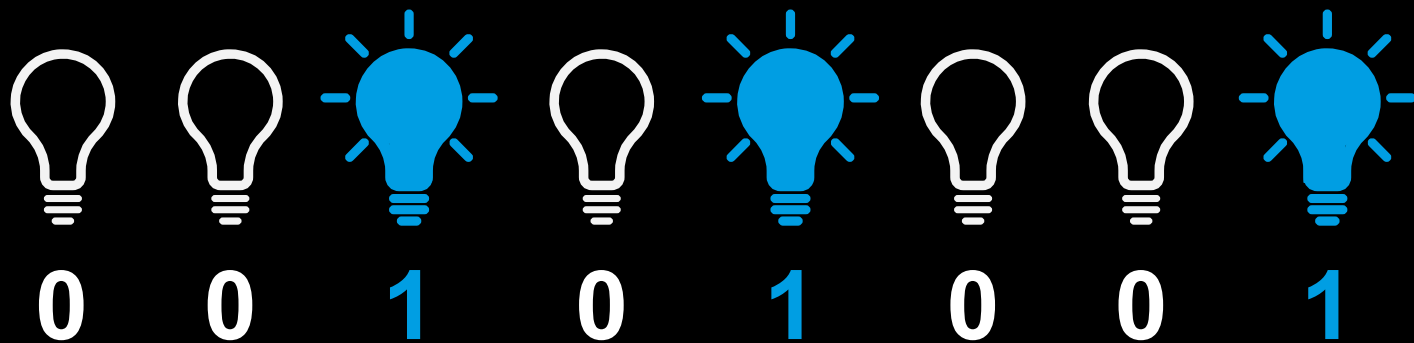
a **bit** (binary digit)



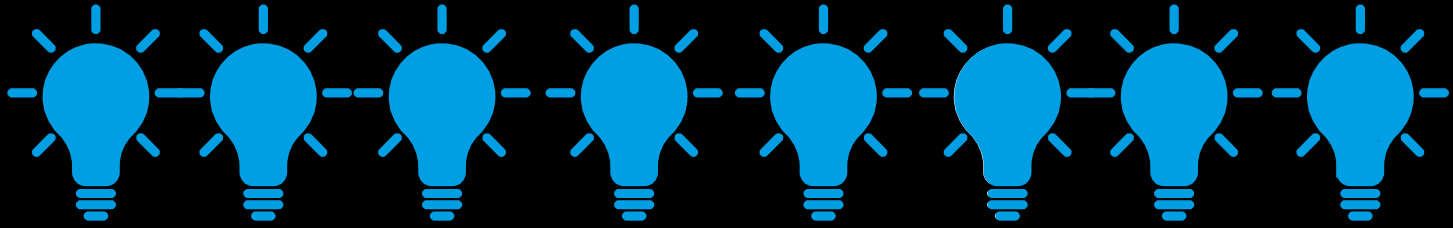
a **byte** (8 bits)



2^7 2^6 2^5 2^4 2^3 2^2 2^1 2^0



2^7 2^6 2^5 2^4 2^3 2^2 2^1 2^0
128 64 32 16 8 4 2 1



what can we store in one byte?

what comes after the byte?

2^{10} bytes = 1.024 bytes = 1 Kibibyte (KiB)

2^{20} bytes = 1.048.576 bytes = 1 Mebibyte (MiB)

2^{30} bytes = 1.073.741.824 bytes = 1 Gibibyte (GiB)

10^3 bytes = 1.000 bytes = 1 Kilobyte (KB)

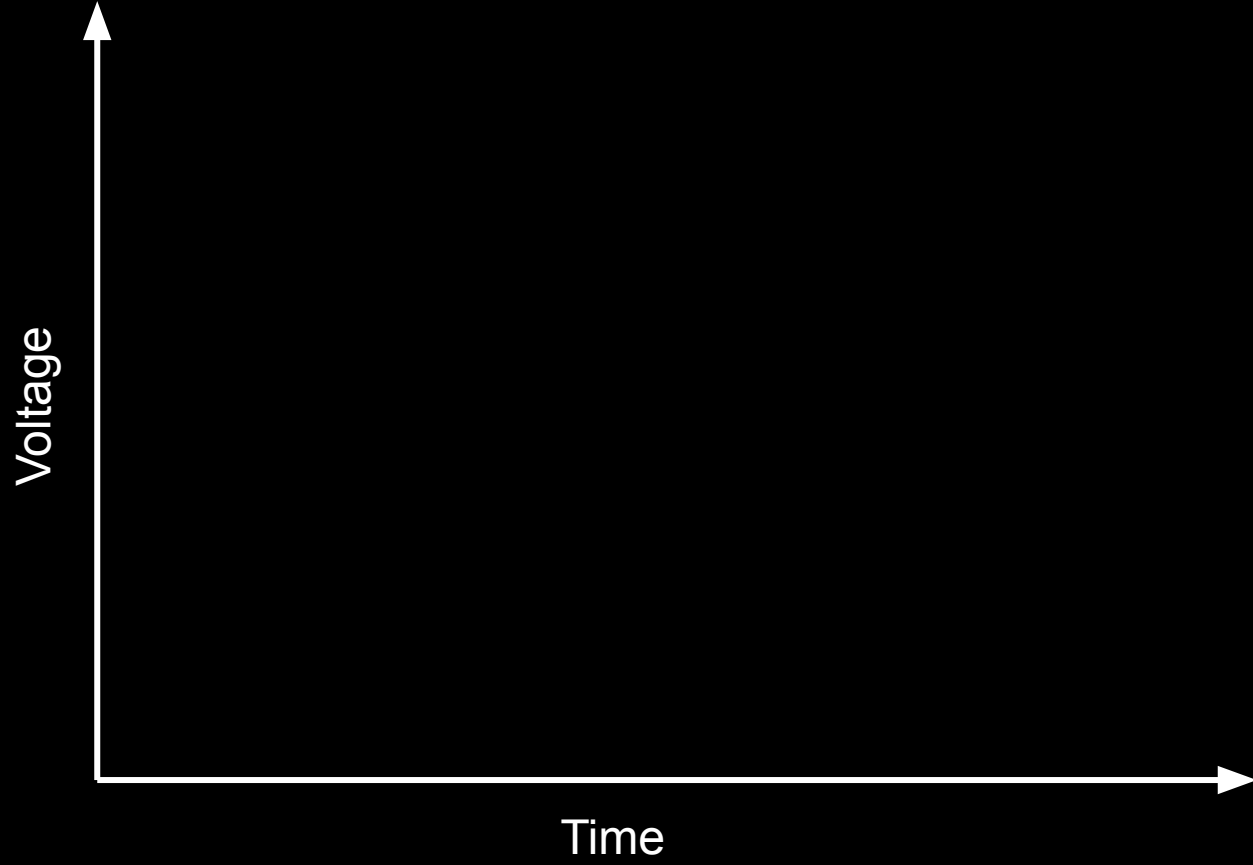
10^6 bytes = 1.000.000 bytes = 1 Megabyte (MB)

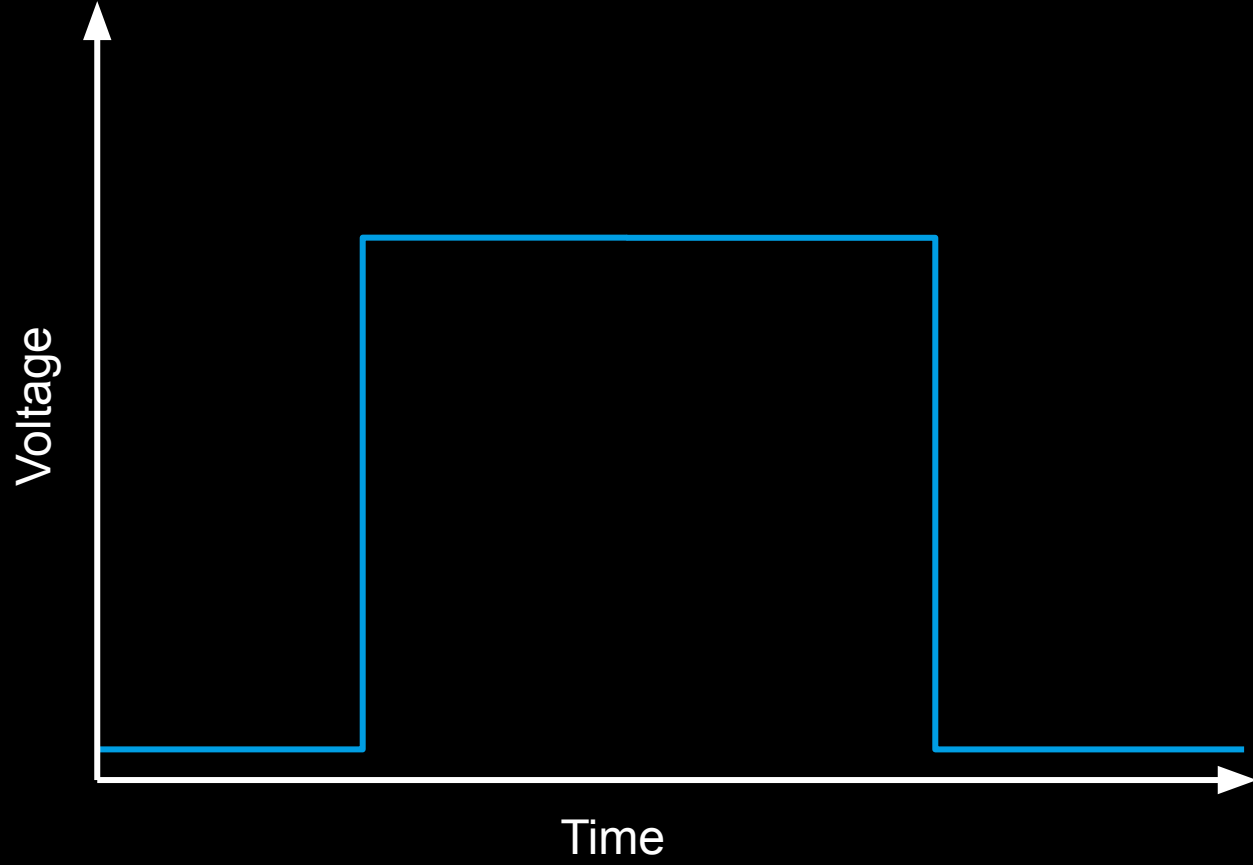
10^9 bytes = 1.000.000.000 bytes = 1 Gigabyte (GB)

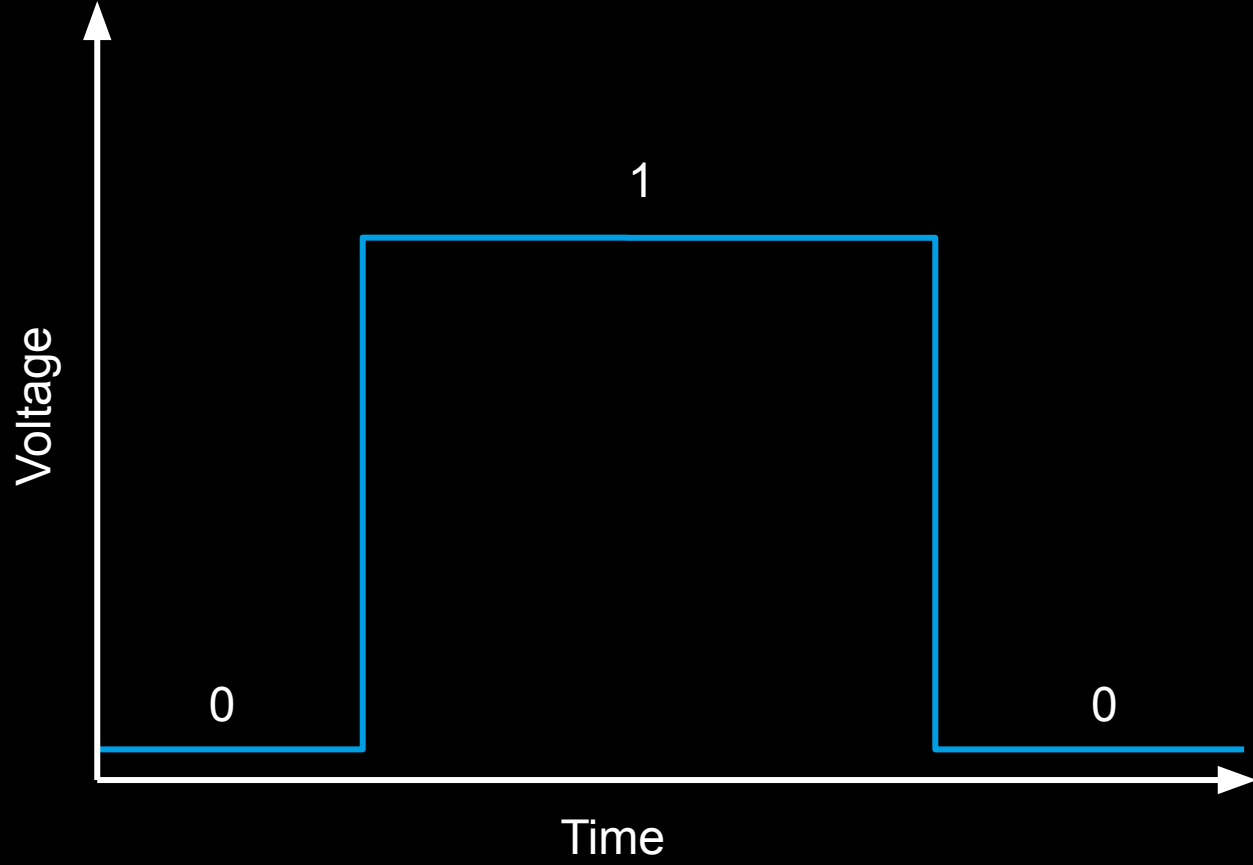
10^{12} bytes = ?

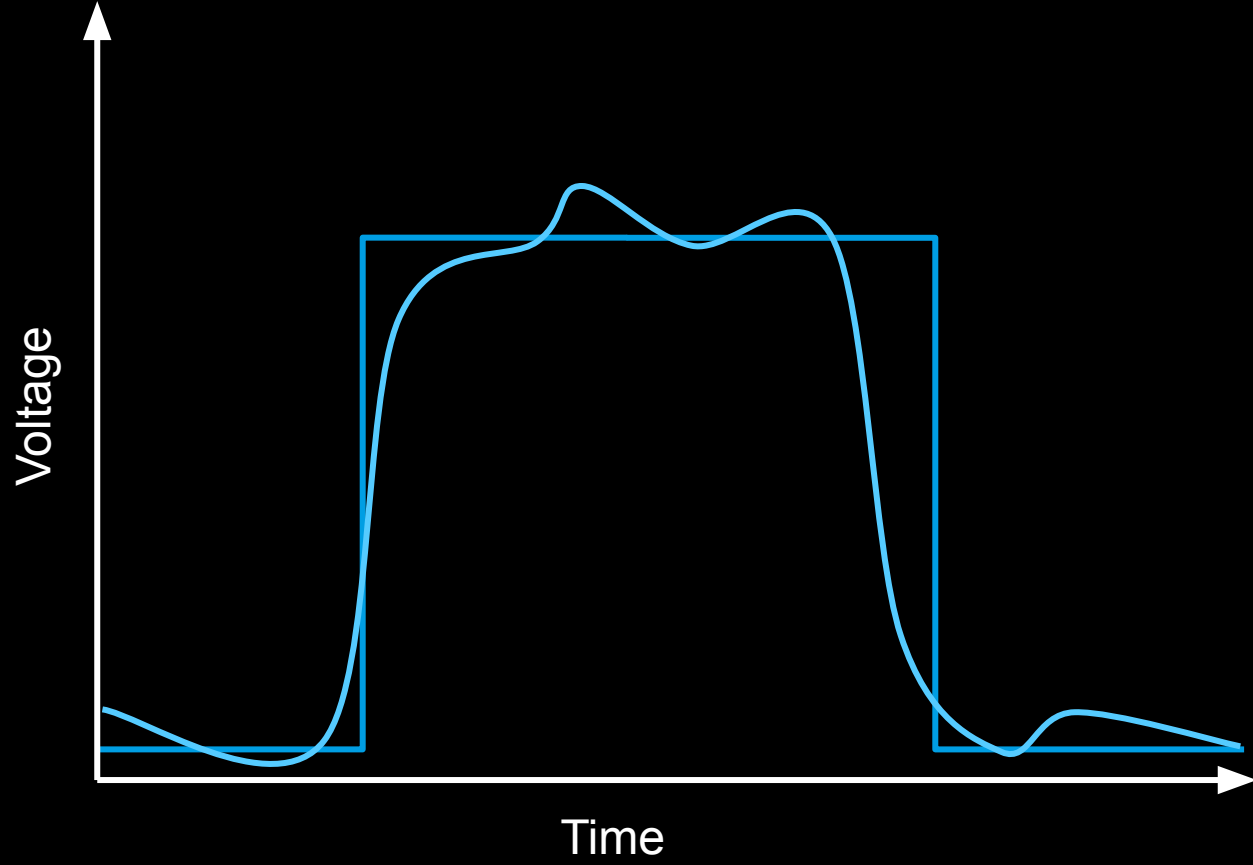
how many bits are on a DVD with
4.7 GB capacity?

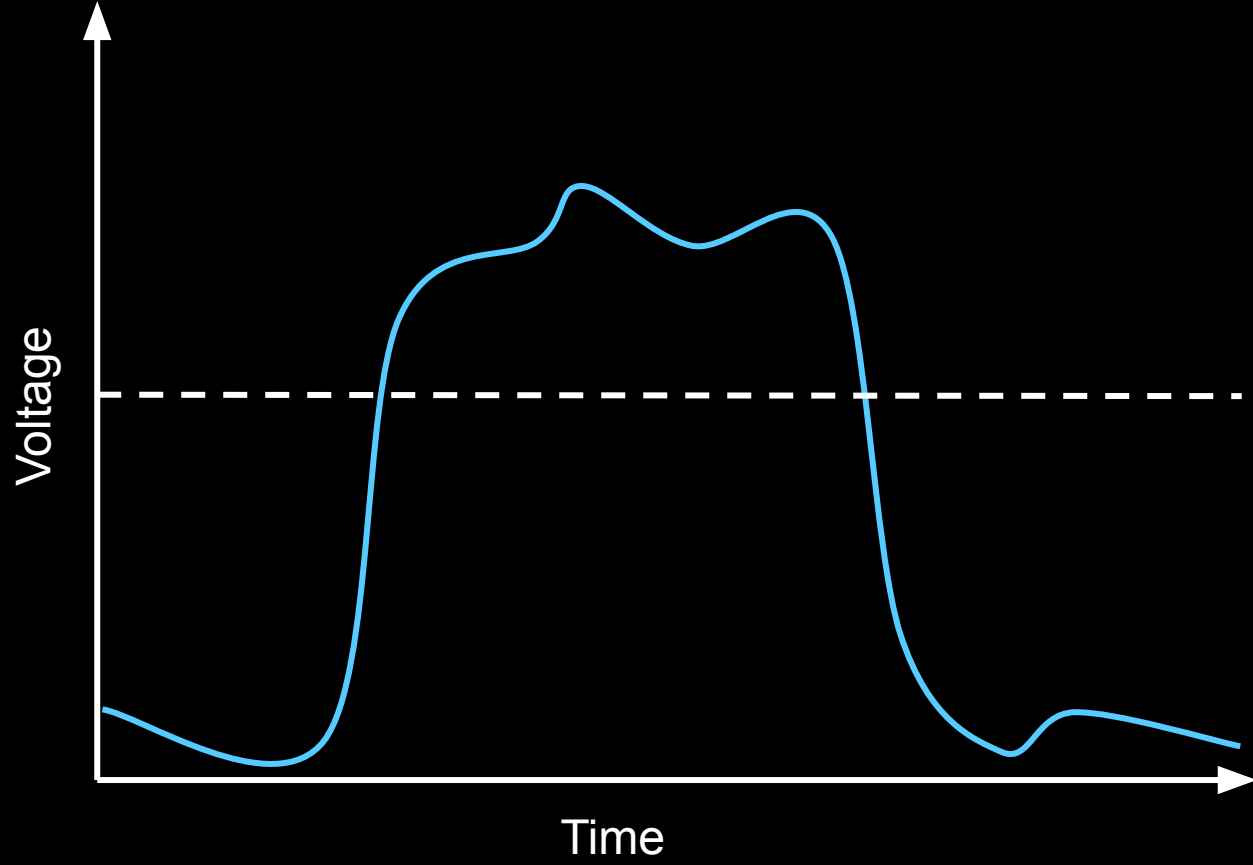
are we stuck with binary?

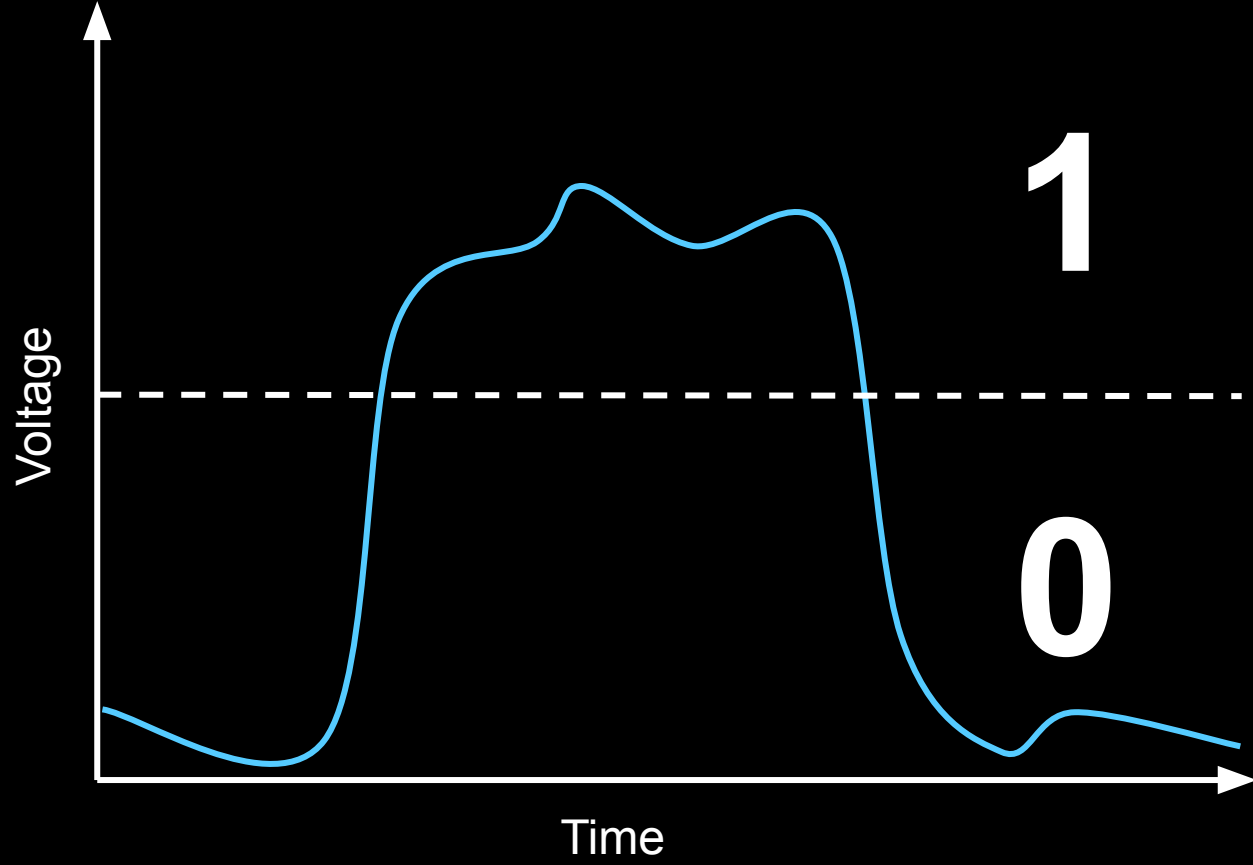


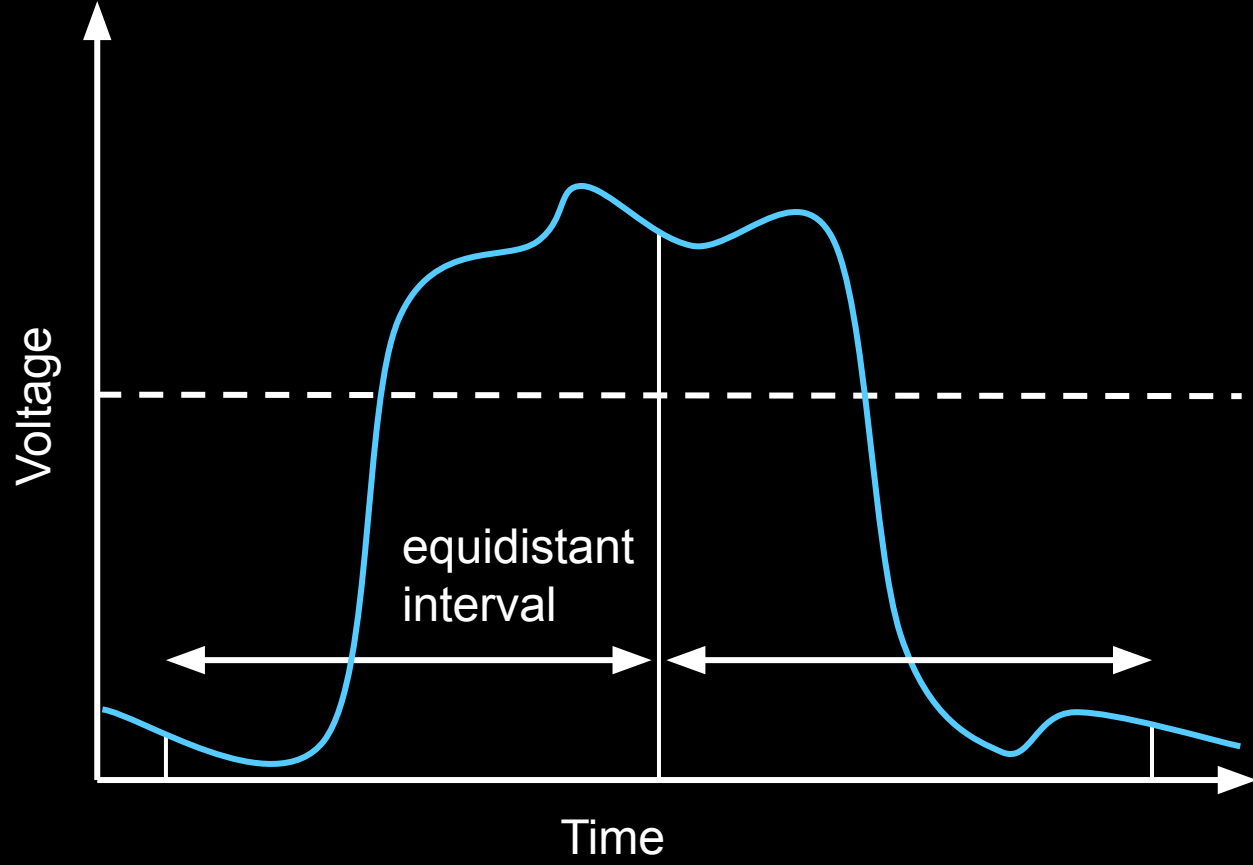


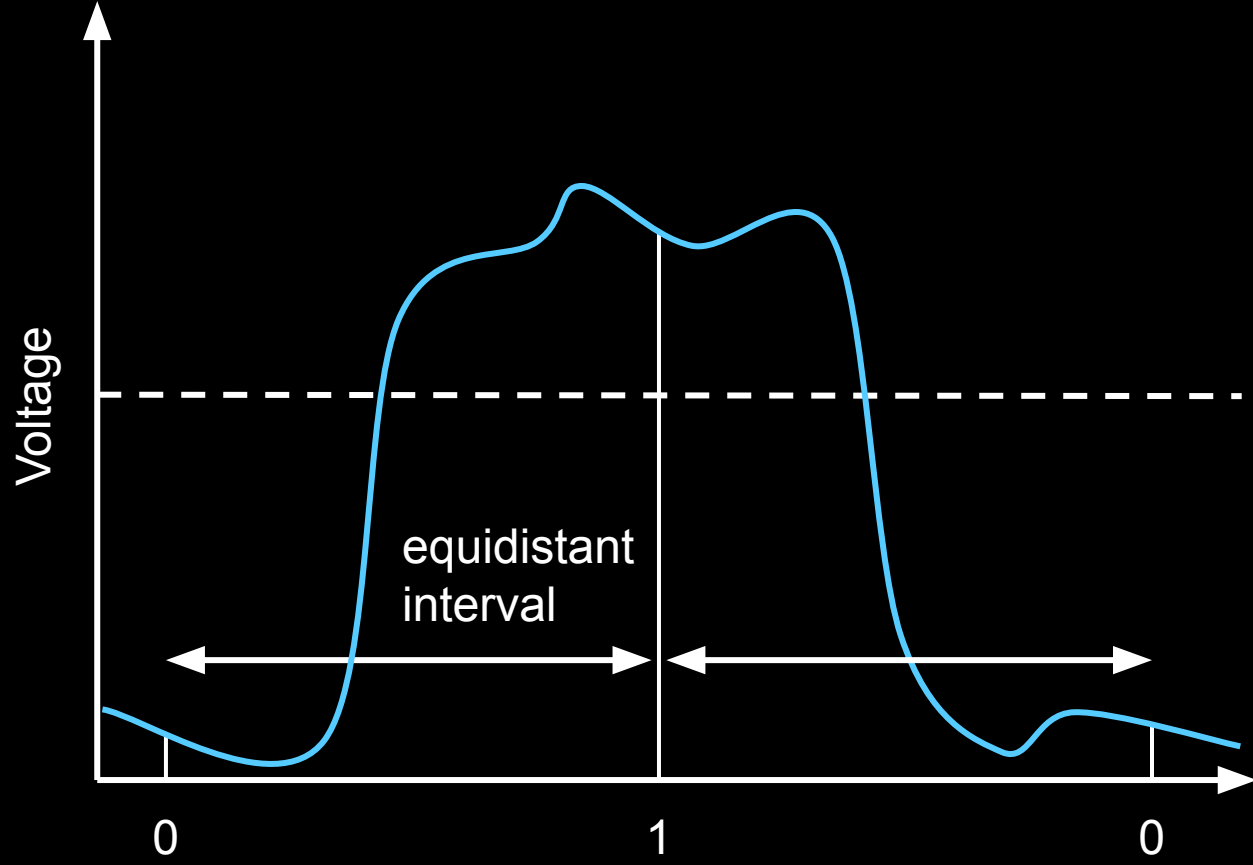


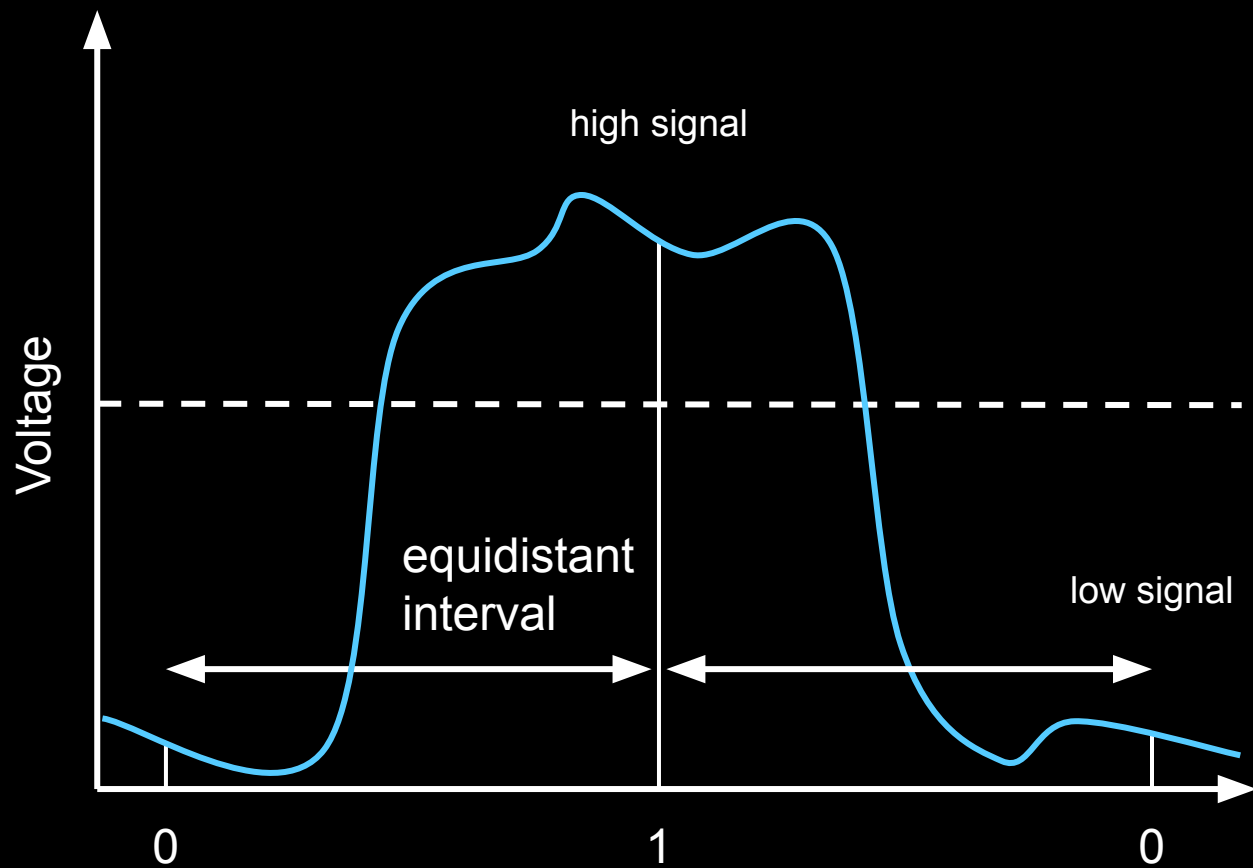




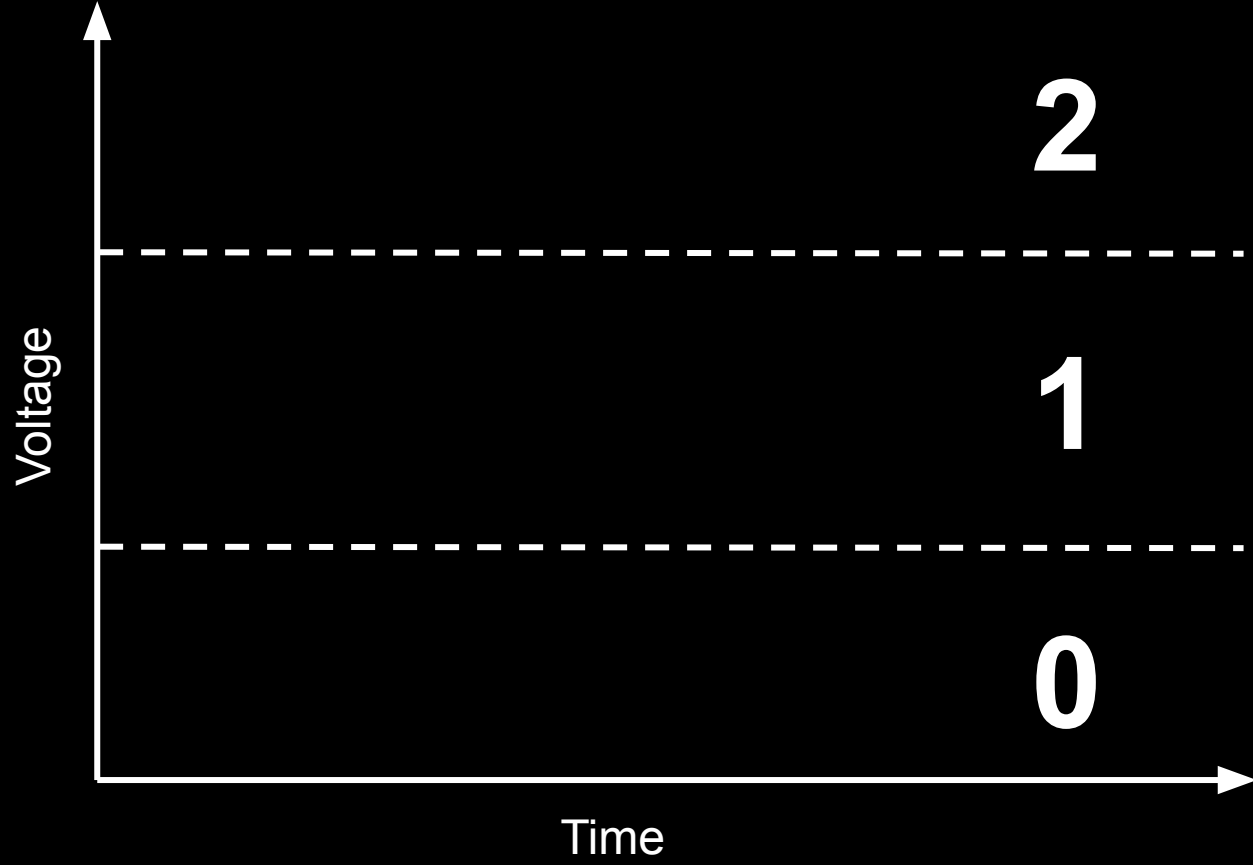


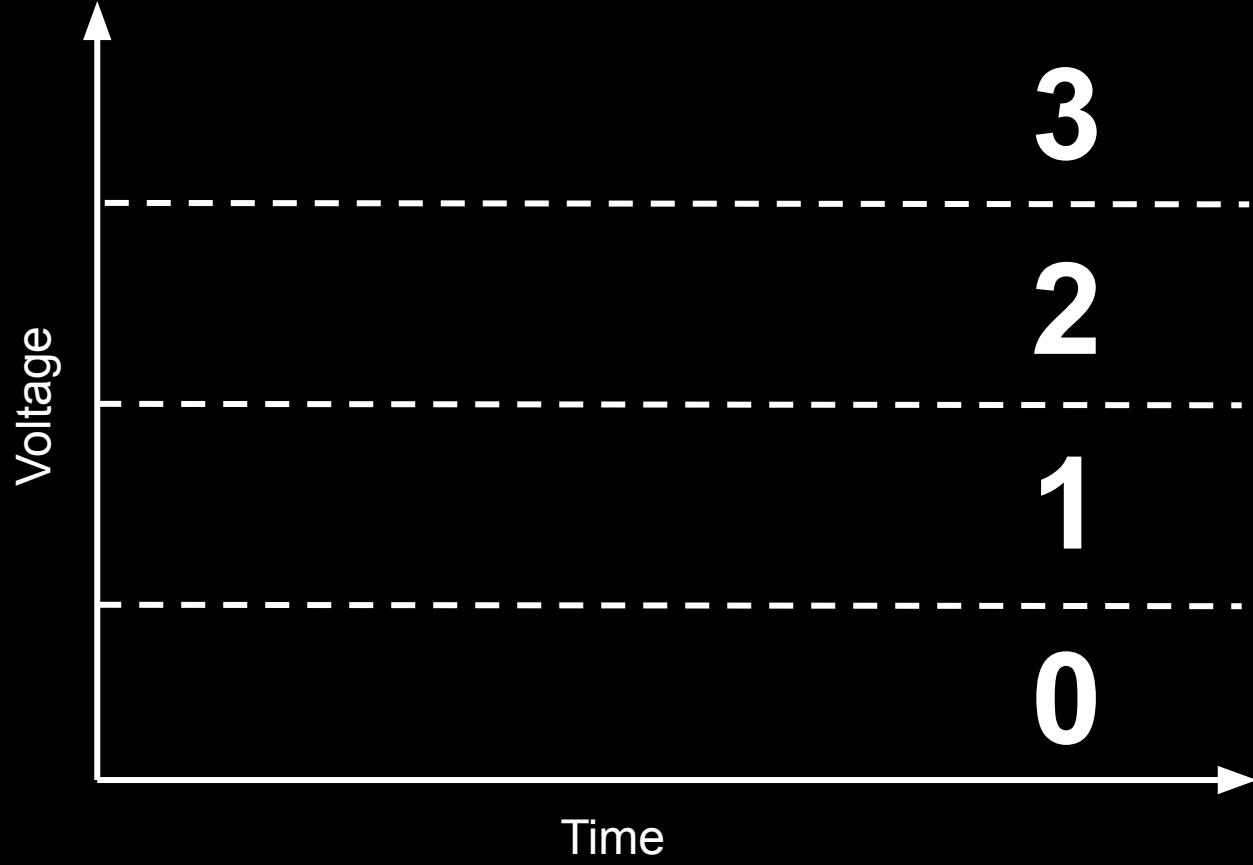


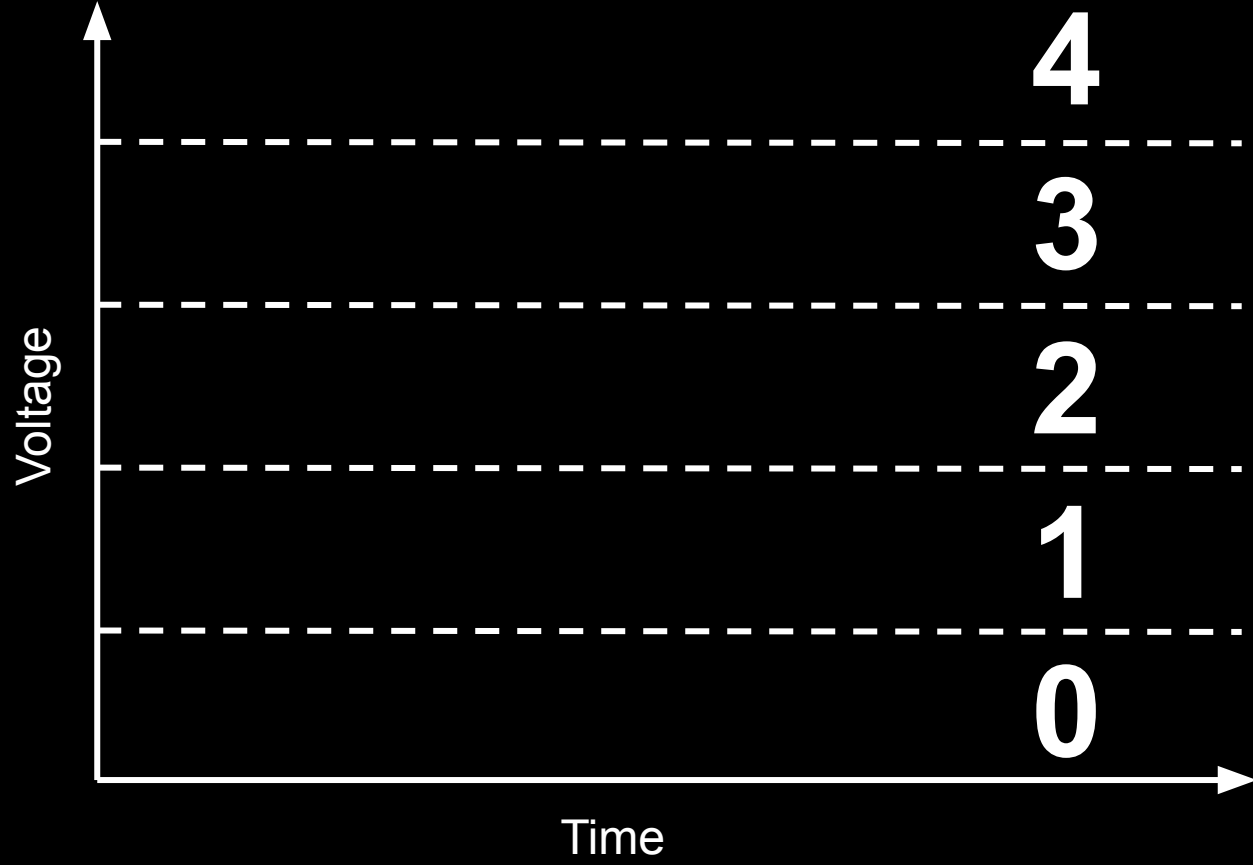


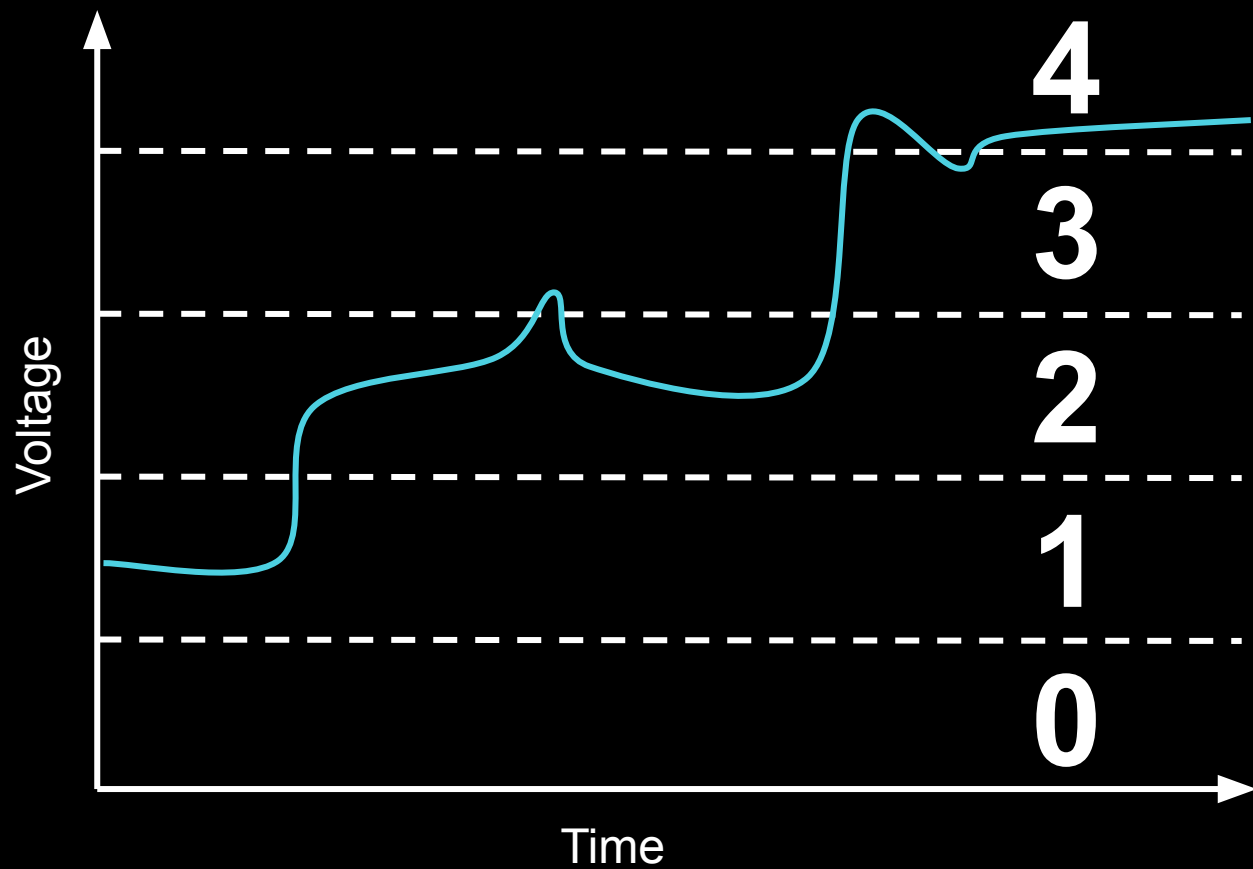


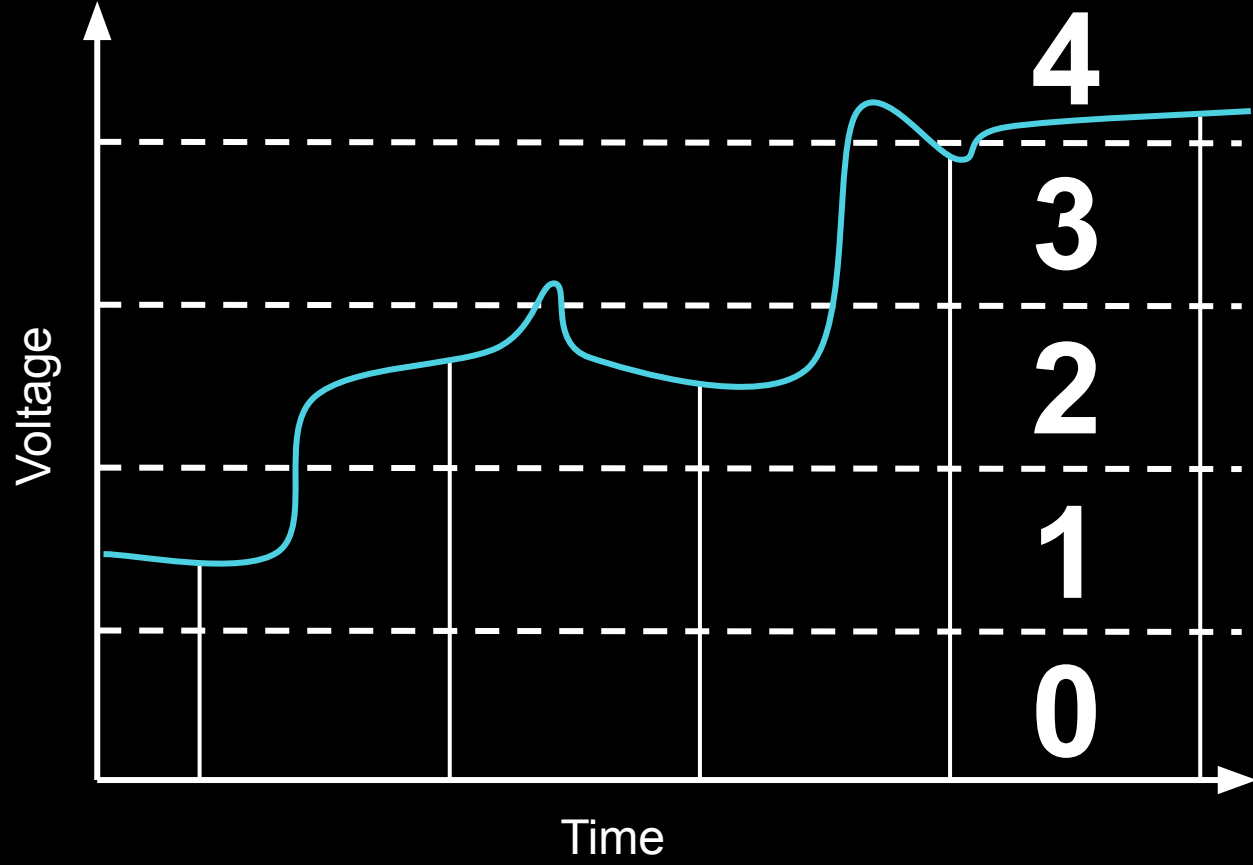
what about $R > 2$?

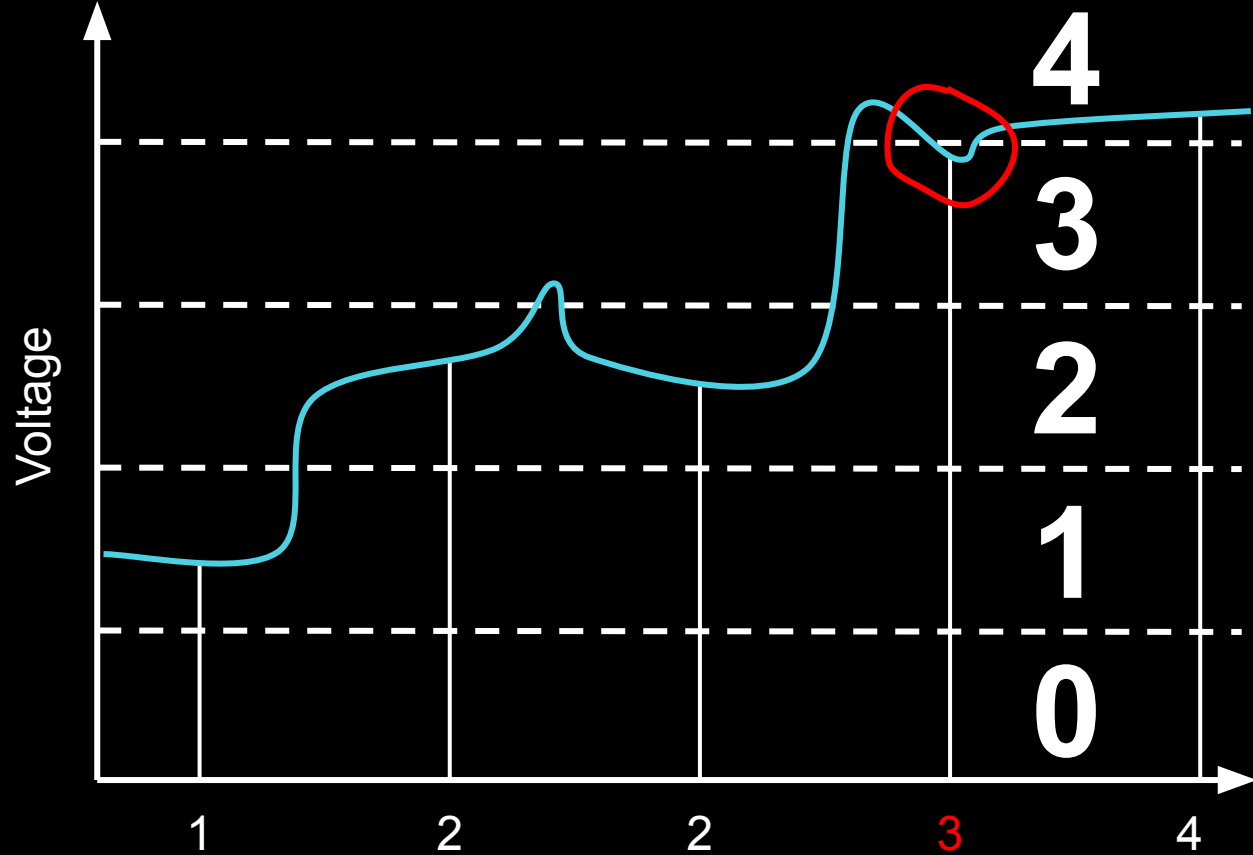












a higher base means less hardware

a higher base means less hardware
but more complex devices

a higher base means less hardware
but more complex devices
and more errors

CODES



MORSE CODE

(ALPHABETICAL)

A	• —	N	— •
B	— • • •	O	— — —
C	— • — •	P	• — — •
D	— • •	Q	— — • —
E	•	R	• — •
F	• • — •	S	• • •
G	— — •	T	—
H	• • • •	U	• • —
I	• •	V	• • • —
J	• — — —	W	• — —
K	— • —	X	— • • —
L	• — • •	Y	— • — —
M	— —	Z	— — • •
1	• — — — —	6	— • • • •
2	• • — — —	7	— — • • •
3	• • • — —	8	— — — • •
4	• • • • —	9	— — — — •
5	• • • • •	0	— — — — —

representing text

A	B	C	D	...	a	b	c	d
65	66	67	68		97	98	99	100

ASCII Code

A	B	C	D	...	a	b	c	d
65	66	67	68		97	98	99	100

Decimal	Binary	Octal	Hex	ASCII	Decimal	Binary	Octal	Hex	ASCII	Decimal	Binary	Octal	Hex	ASCII	Decimal	Binary	Octal	Hex	ASCII
0	00000000	000	00	NUL	32	00100000	040	20	SP	64	01000000	100	40	@	96	01100000	140	60	`
1	00000001	001	01	SOH	33	00100001	041	21	!	65	01000001	101	41	A	97	01100001	141	61	a
2	00000010	002	02	STX	34	00100010	042	22	"	66	01000010	102	42	B	98	01100010	142	62	b
3	00000011	003	03	ETX	35	00100011	043	23	#	67	01000011	103	43	C	99	01100011	143	63	c
4	00000100	004	04	EOT	36	00100100	044	24	\$	68	01000100	104	44	D	100	01100100	144	64	d
5	00000101	005	05	ENQ	37	00100101	045	25	%	69	01000101	105	45	E	101	01100101	145	65	e
6	00000110	006	06	ACK	38	00100110	046	26	&	70	01000110	106	46	F	102	01100110	146	66	f
7	00000111	007	07	BEL	39	00100111	047	27	'	71	01000111	107	47	G	103	01100111	147	67	g
8	00001000	010	08	BS	40	00101000	050	28	(72	01001000	110	48	H	104	01101000	150	68	h
9	00001001	011	09	HT	41	00101001	051	29)	73	01001001	111	49	I	105	01101001	151	69	i
10	00001010	012	0A	LF	42	00101010	052	2A	*	74	01001010	112	4A	J	106	01101010	152	6A	j
11	00001011	013	0B	VT	43	00101011	053	2B	+	75	01001011	113	4B	K	107	01101011	153	6B	k
12	00001100	014	0C	FF	44	00101100	054	2C	,	76	01001100	114	4C	L	108	01101100	154	6C	l
13	00001101	015	0D	CR	45	00101101	055	2D	-	77	01001101	115	4D	M	109	01101101	155	6D	m
14	00001110	016	0E	SO	46	00101110	056	2E	.	78	01001110	116	4E	N	110	01101110	156	6E	n
15	00001111	017	0F	SI	47	00101111	057	2F	/	79	01001111	117	4F	O	111	01101111	157	6F	o
16	00010000	020	10	DLE	48	00110000	060	30	0	80	01010000	120	50	P	112	01110000	160	70	p
17	00010001	021	11	DC1	49	00110001	061	31	1	81	01010001	121	51	Q	113	01110001	161	71	q
18	00010010	022	12	DC2	50	00110010	062	32	2	82	01010010	122	52	R	114	01110010	162	72	r
19	00010011	023	13	DC3	51	00110011	063	33	3	83	01010011	123	53	S	115	01110011	163	73	s
20	00010100	024	14	DC4	52	00110100	064	34	4	84	01010100	124	54	T	116	01110100	164	74	t
21	00010101	025	15	NAK	53	00110101	065	35	5	85	01010101	125	55	U	117	01110101	165	75	u
22	00010110	026	16	SYN	54	00110110	066	36	6	86	01010110	126	56	V	118	01110110	166	76	v
23	00010111	027	17	ETB	55	00110111	067	37	7	87	01010111	127	57	W	119	01110111	167	77	w
24	00011000	030	18	CAN	56	00111000	070	38	8	88	01011000	130	58	X	120	01111000	170	78	x
25	00011001	031	19	EM	57	00111001	071	39	9	89	01011001	131	59	Y	121	01111001	171	79	y
26	00011010	032	1A	SUB	58	00111010	072	3A	:	90	01011010	132	5A	Z	122	01111010	172	7A	z
27	00011011	033	1B	ESC	59	00111011	073	3B	;	91	01011011	133	5B	[123	01111011	173	7B	{
28	00011100	034	1C	FS	60	00111100	074	3C	<	92	01011100	134	5C	\	124	01111100	174	7C	
29	00011101	035	1D	GS	61	00111101	075	3D	=	93	01011101	135	5D]	125	01111101	175	7D	}
30	00011110	036	1E	RS	62	00111110	076	3E	>	94	01011110	136	5E	^	126	01111110	176	7E	~
31	00011111	037	1F	US	63	00111111	077	3F	?	95	01011111	137	5F	_	127	01111111	177	7F	DEL



1F600



1F601



1F602



1F603

...



1F648



1F649



1F64A



1F64B

Unicode



1F600



1F601



1F602



1F603

...



1F648



1F649



1F64A



1F64B

hexadecimal

1

A

D

(hexadecimal)

16^2

16^1

16^0

1 A D

(hexadecimal)

16^2

16^1

16^0

$$= 1 \times 16^2 + 10 \times 16^1 + 13 \times 16^0$$

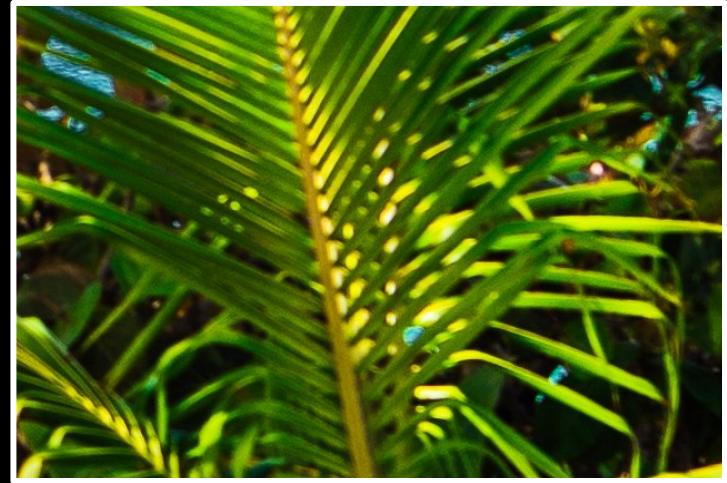
$$= 1 \times 256 + 10 \times 16 + 13 \times 1$$

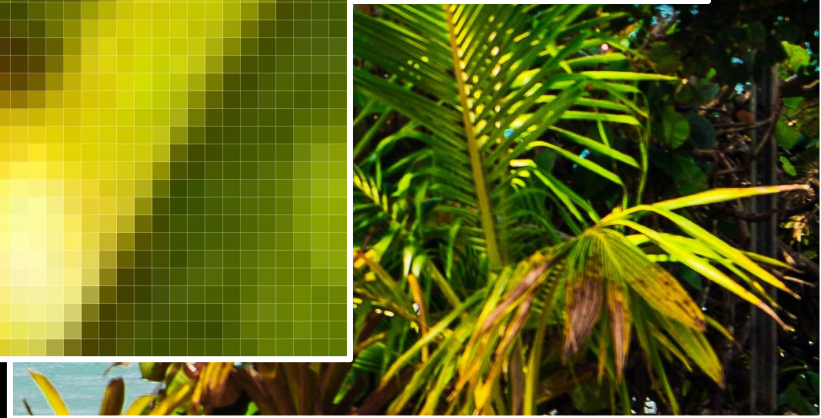
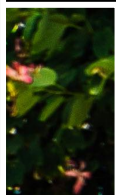
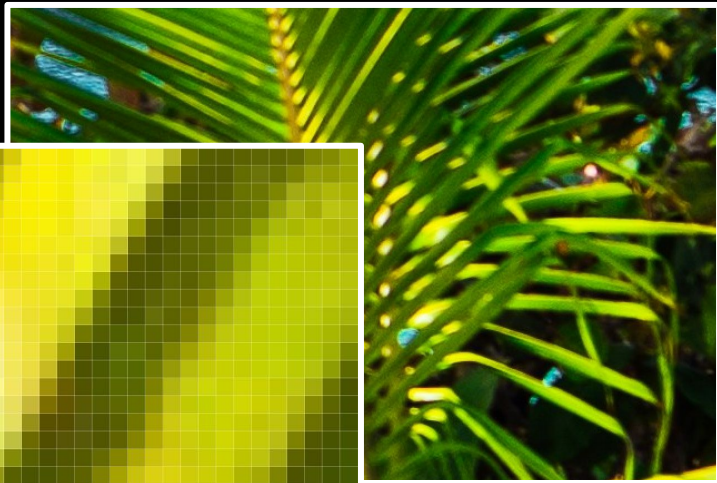
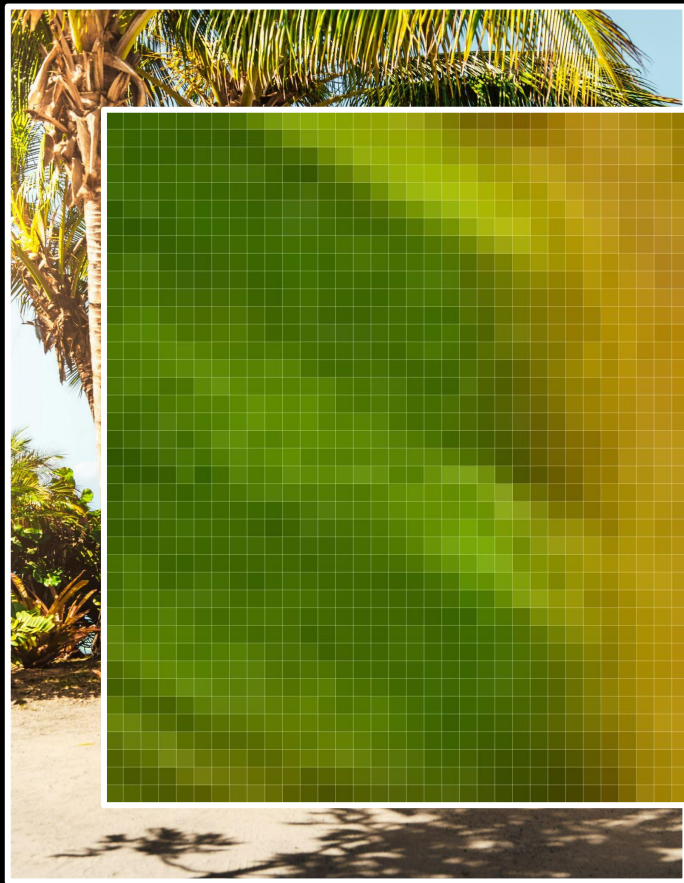
$$= 429 \text{ (decimal)}$$

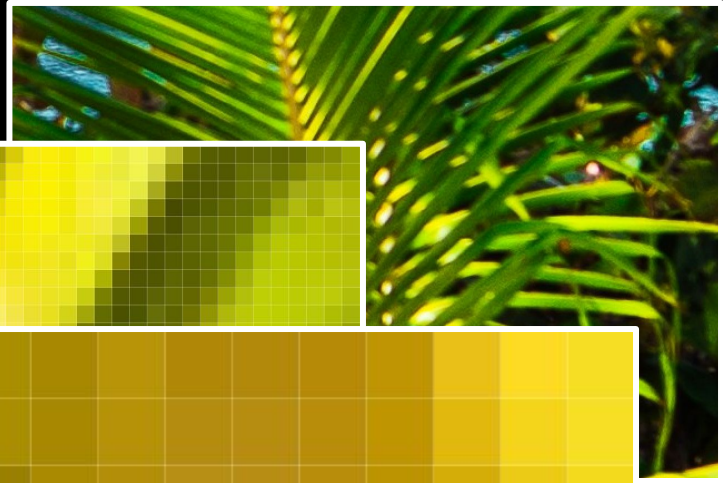
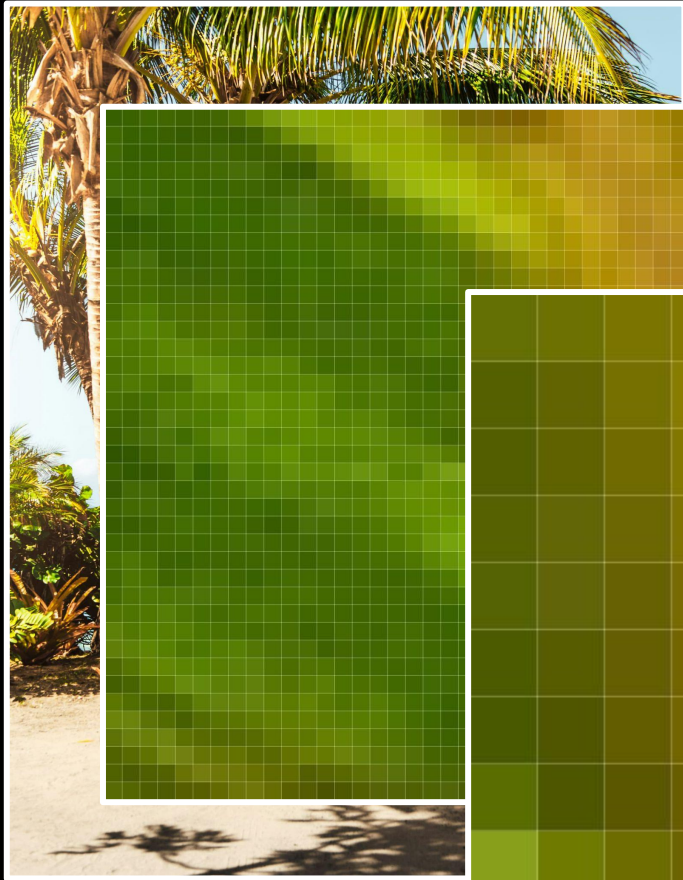
representing images

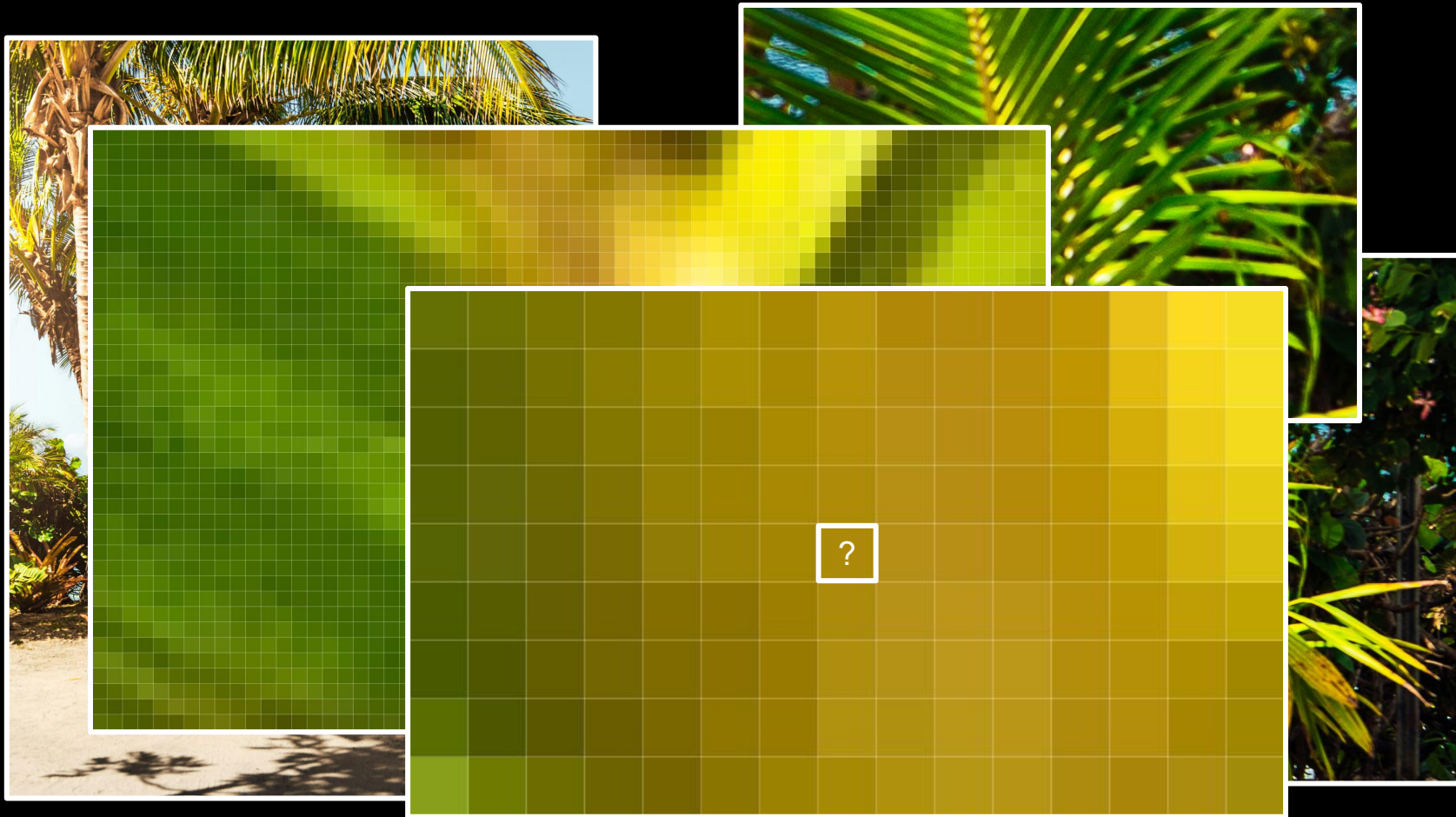




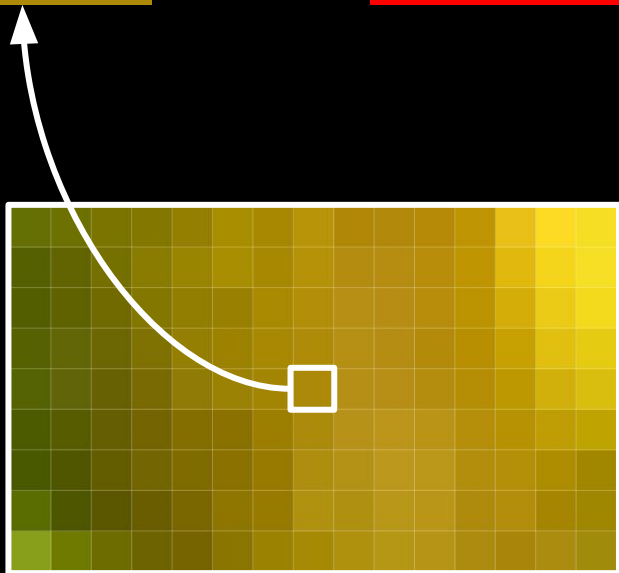






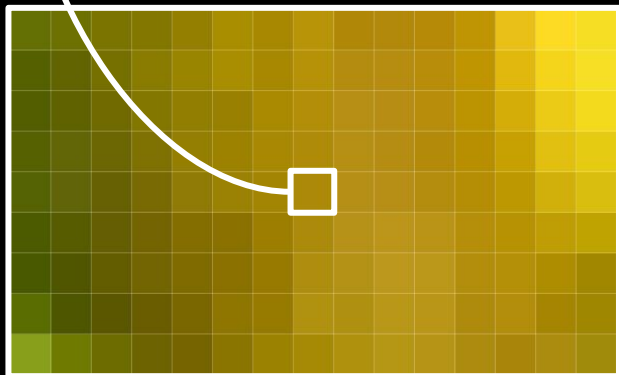


$$\text{[Olive Box]} = \text{[Red Box R]} + \text{[Green Box G]} + \text{[Blue Box B]}$$



$$\text{[Olive Box]} = \text{[Red Box R]} + \text{[Green Box G]} + \text{[Blue Box B]}$$

172 137 9





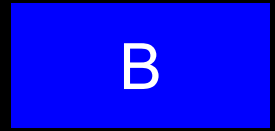
=



+



+

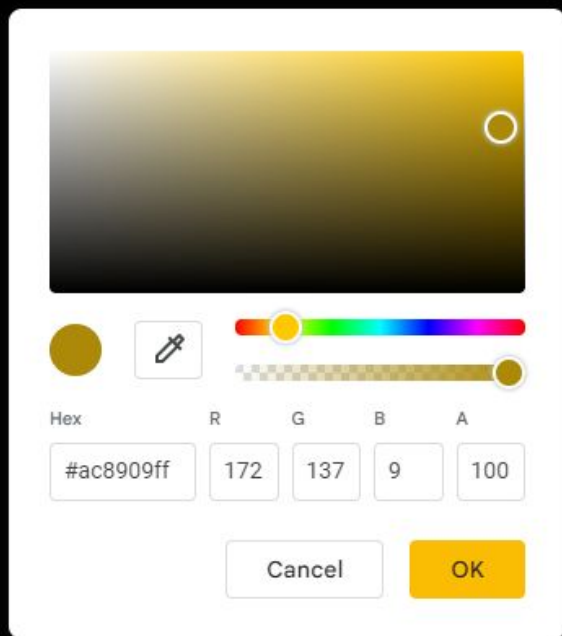


172

137

9

#AC8909





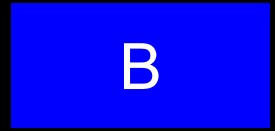
=



+



+



172

137

9

#AC8909

AC

89

09



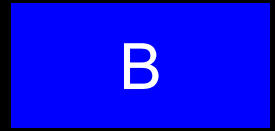
=



+



+



172

137

9

#AC8909

AC

89

09

10101100

01011001

00001001

possible colors?



R

2^7 2^6 2^5 2^4 2^3 2^2 2^1 2^0



R



G

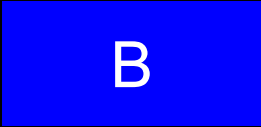


B

2^{23} 2^{22} 2^{21} 2^{20} 2^{19} 2^{18} 2^{17} 2^{16}

2^{15} 2^{14} 2^{13} 2^{12} 2^{11} 2^{10} 2^9 2^8

2^7 2^6 2^5 2^4 2^3 2^2 2^1 2^0



$2^{23} 2^{22} 2^{21} 2^{20} 2^{19} 2^{18} 2^{17} 2^{16}$

$2^{15} 2^{14} 2^{13} 2^{12} 2^{11} 2^{10} 2^9 2^8$

$2^7 2^6 2^5 2^4 2^3 2^2 2^1 2^0$



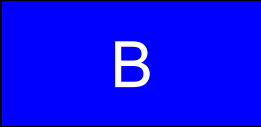
256

×

256

×

256



$2^{23} 2^{22} 2^{21} 2^{20} 2^{19} 2^{18} 2^{17} 2^{16}$

$2^{15} 2^{14} 2^{13} 2^{12} 2^{11} 2^{10} 2^9 2^8$

$2^7 2^6 2^5 2^4 2^3 2^2 2^1 2^0$



256

×

256

×

256

16.777.216



grayscale



grayscale

256 shades of gray



grayscale

256 shades of gray

how many bits ?



grayscale

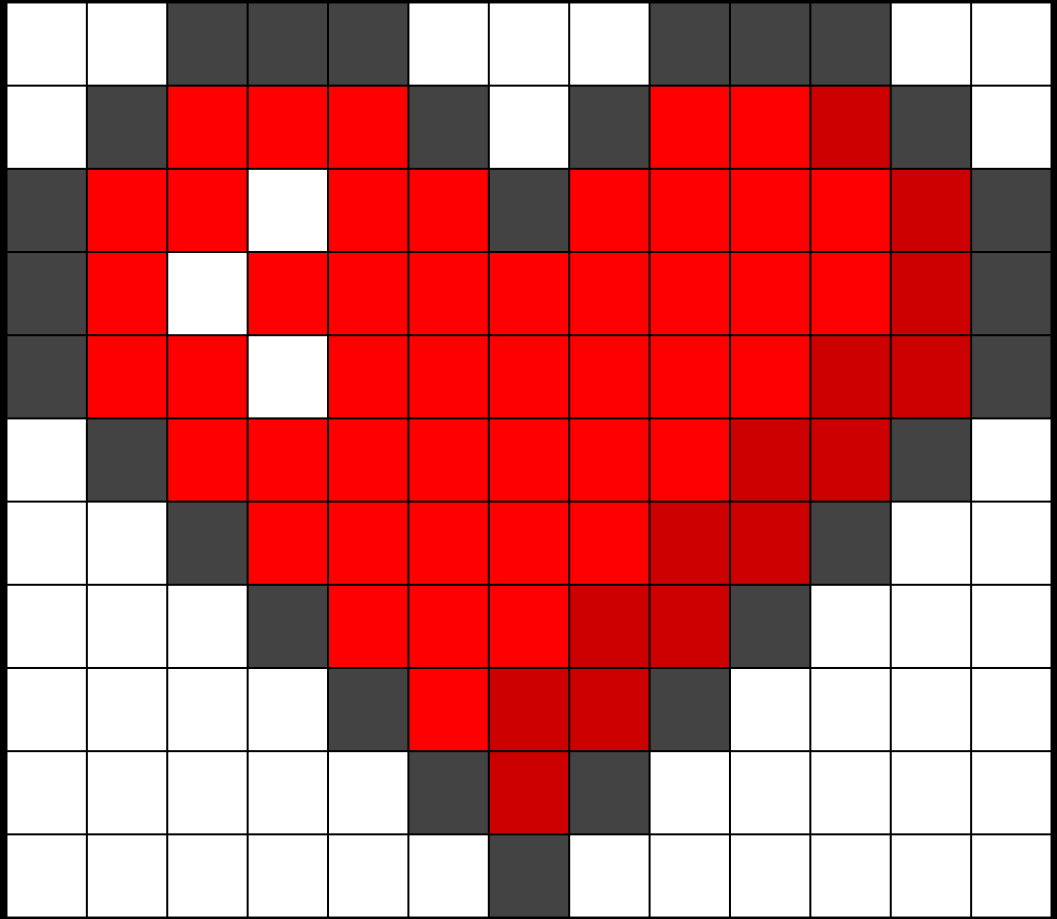
256 shades of gray

how many bits ?



black/white

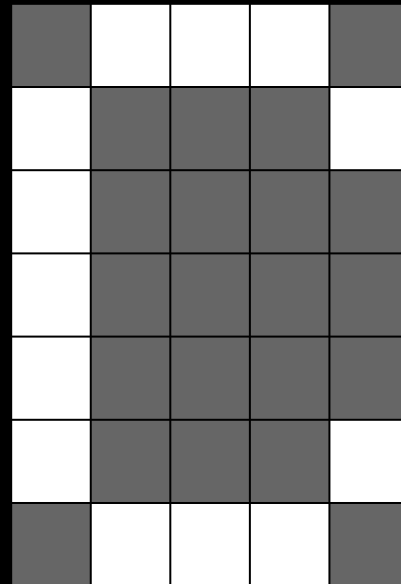
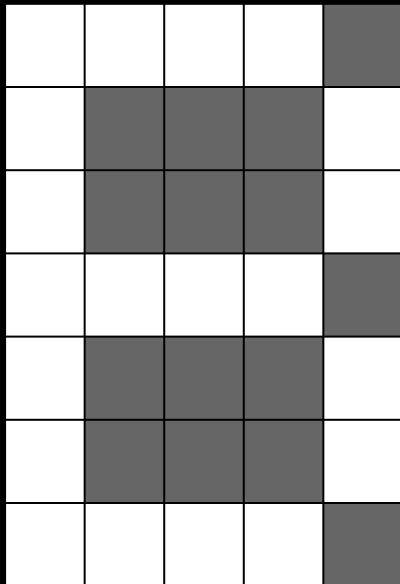
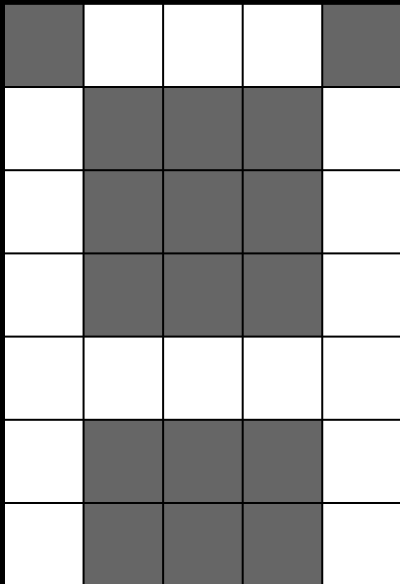


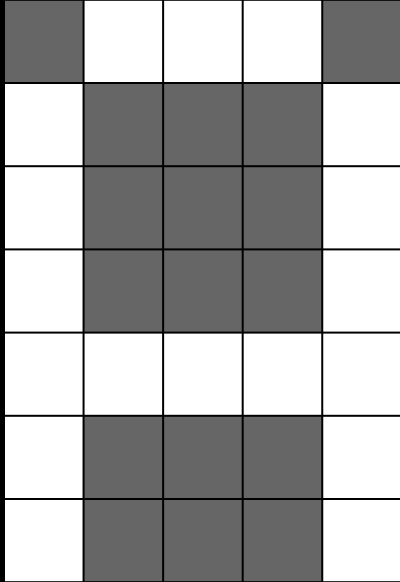




compression?

fonts





0	1	1	1	0
1	0	0	0	1
1	0	0	0	1
1	0	0	0	1
1	1	1	1	1
1	0	0	0	1
1	0	0	0	1

0	1	1	1	0
1	0	0	0	1
1	0	0	0	1
1	0	0	0	1
1	1	1	1	1
1	0	0	0	1
1	0	0	0	1



0 1 1 1 0 1 0 0 0 1 1 0 0 0 1 1 0 0
0 1 1 1 1 1 1 1 0 0 0 1 1 0 0 0 1

5

0	1	1	1	0
1	0	0	0	1
1	0	0	0	1
1	0	0	0	1
1	1	1	1	1
1	0	0	0	1
1	0	0	0	1

7



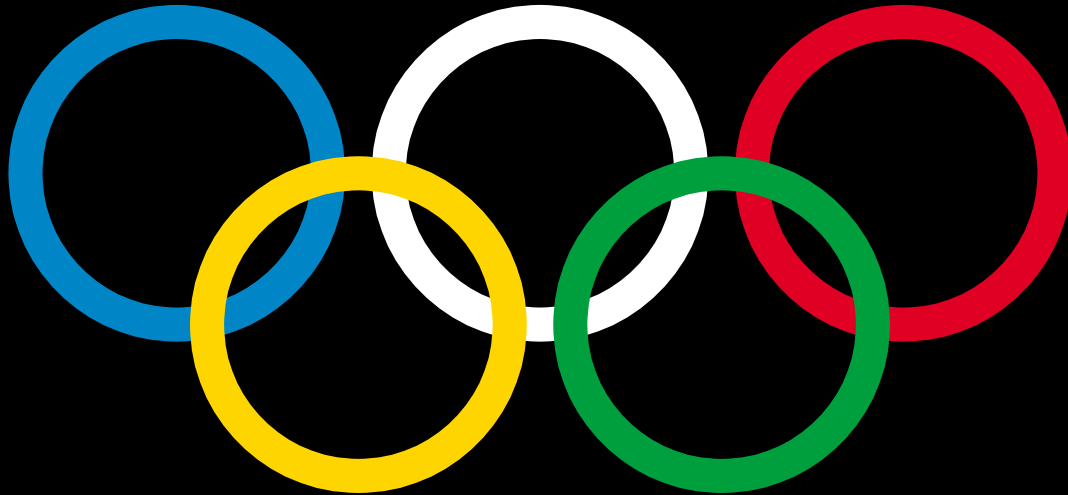
0 1 1 1 0 1 0 0 0 1 1 0 0 0 1 1 0 0
0 1 1 1 1 1 1 1 0 0 0 1 1 0 0 0 1

bitmap

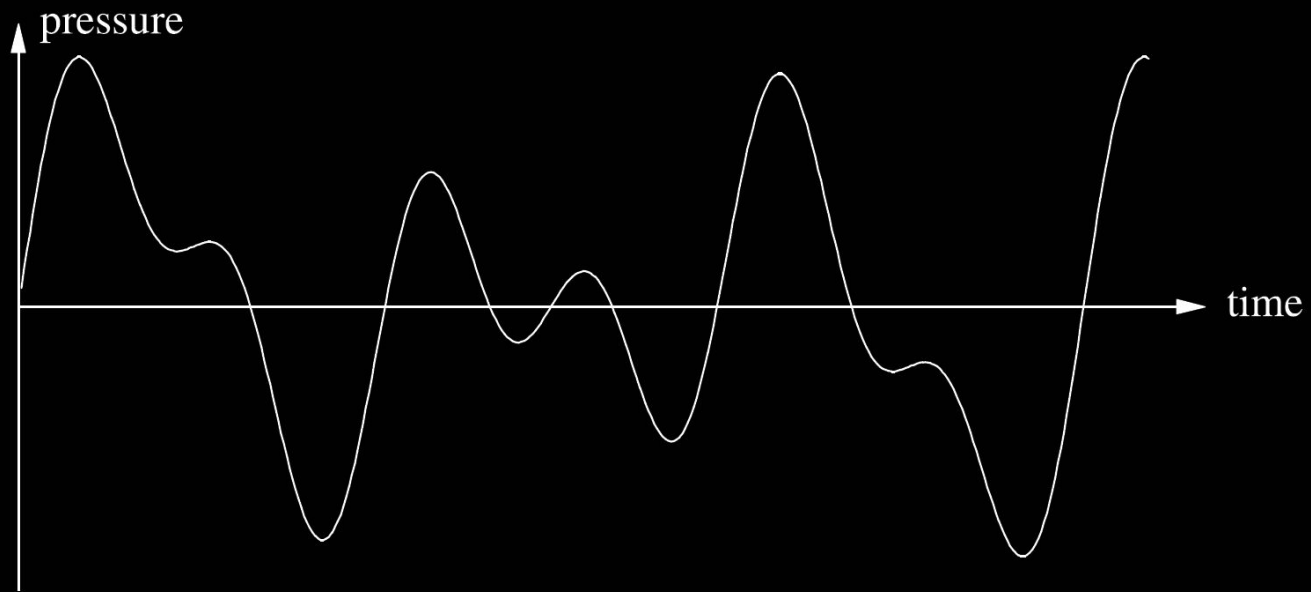
vector graphics

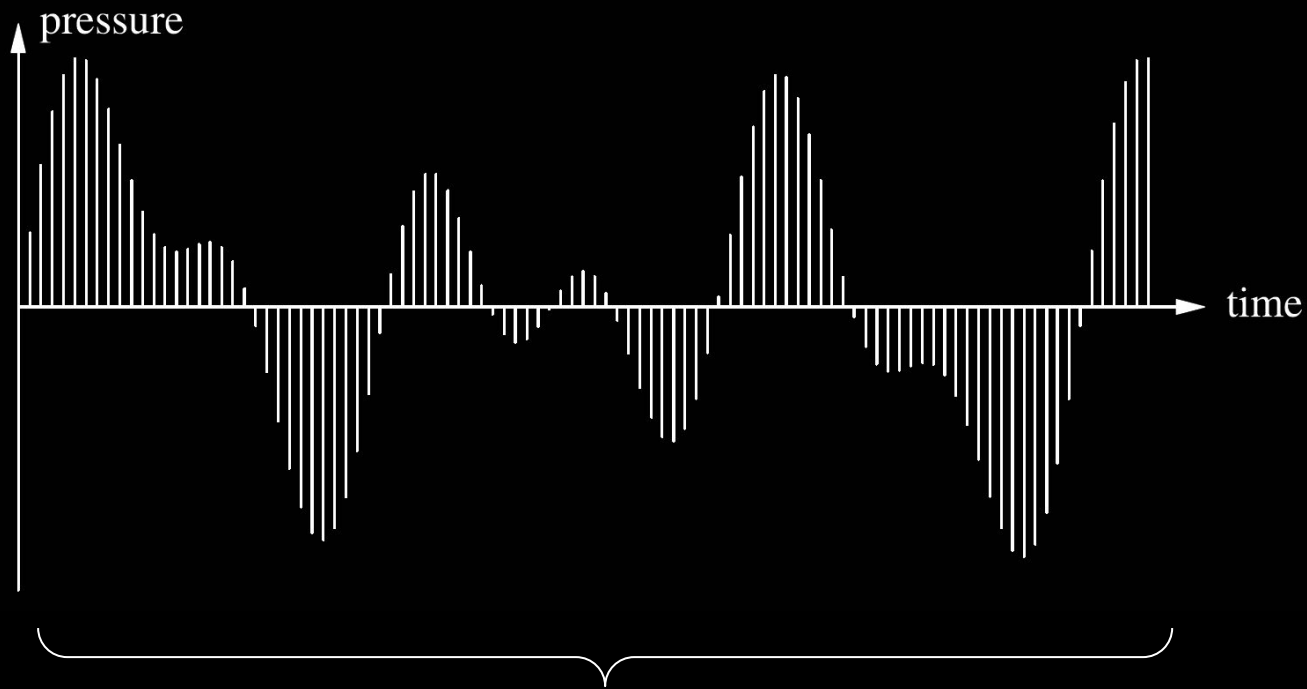
```
<svg width="440" height="220" xmlns="http://www.w3.org/2000/svg">
  <circle cx="60" cy="60" r="50" stroke="#0085C7" stroke-width="10" fill="none" />
  <circle cx="180" cy="60" r="50" stroke="#000000" stroke-width="10" fill="none" />
  <circle cx="300" cy="60" r="50" stroke="#DF0024" stroke-width="10" fill="none" />
  <circle cx="120" cy="110" r="50" stroke="#FFD500" stroke-width="10" fill="none" />
  <circle cx="240" cy="110" r="50" stroke="#009F3D" stroke-width="10" fill="none" />
</svg>
```

```
<svg width="440" height="220" xmlns="http://www.w3.org/2000/svg">  
  <circle cx="60" cy="60" r="50" stroke="#0085C7" stroke-width="10" fill="none" />  
  <circle cx="180" cy="60" r="50" stroke="#000000" stroke-width="10" fill="none" />  
  <circle cx="300" cy="60" r="50" stroke="#DF0024" stroke-width="10" fill="none" />  
  <circle cx="120" cy="110" r="50" stroke="#FFD500" stroke-width="10" fill="none" />  
  <circle cx="240" cy="110" r="50" stroke="#009F3D" stroke-width="10" fill="none" />  
</svg>
```



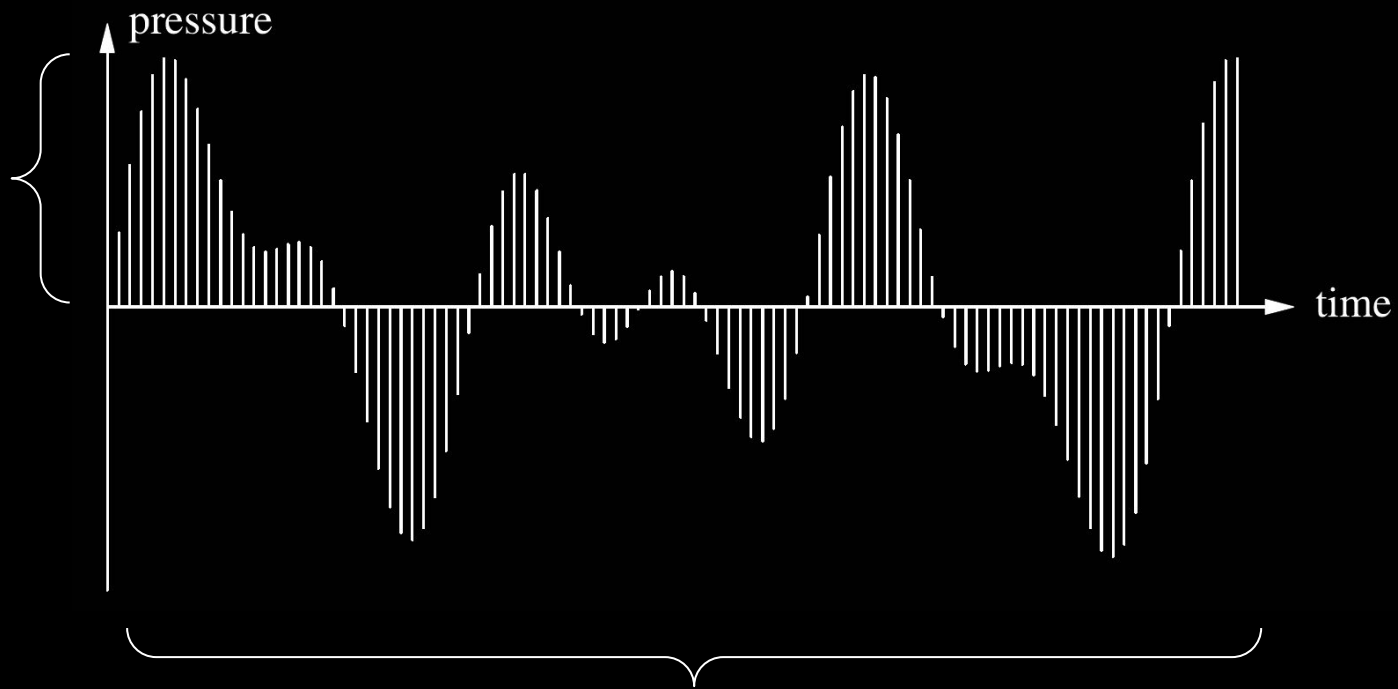
representing sound





how many samples per time unit?

bits per sample?

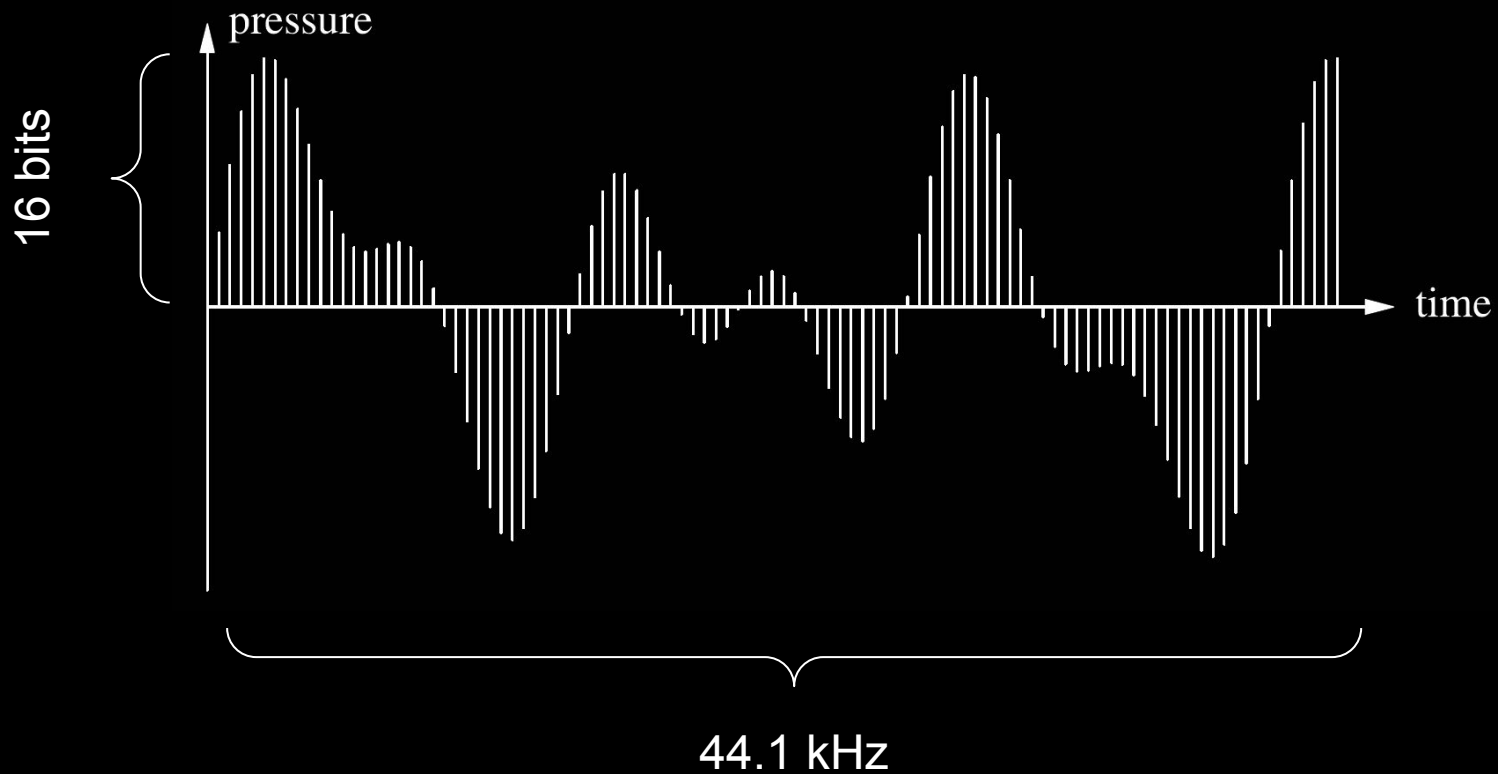


samples per time unit?

telephone

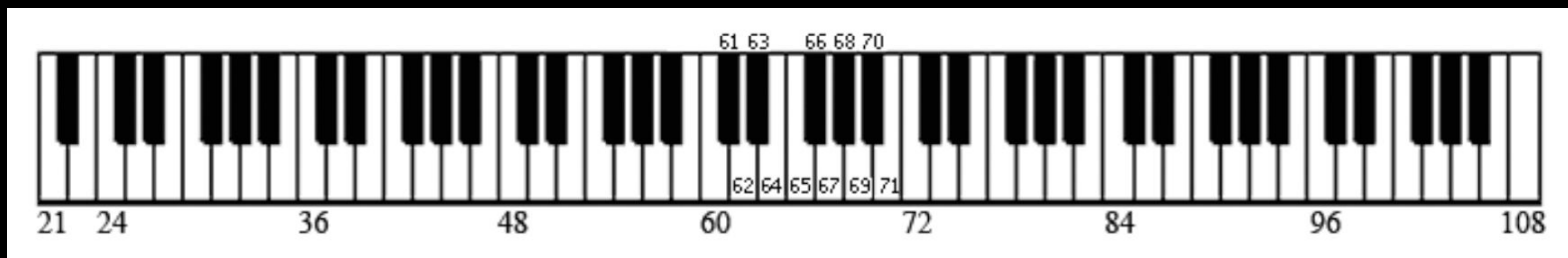


music



musical instrument digital interface (MIDI)

byte 1 = note
byte 2 = velocity



what code systems exist outside
of computers?

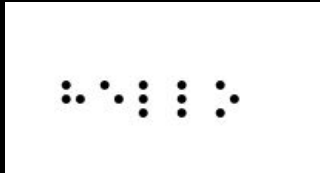
a)



b)



c)



d)

MORSE CODE
(ALPHABETICAL)

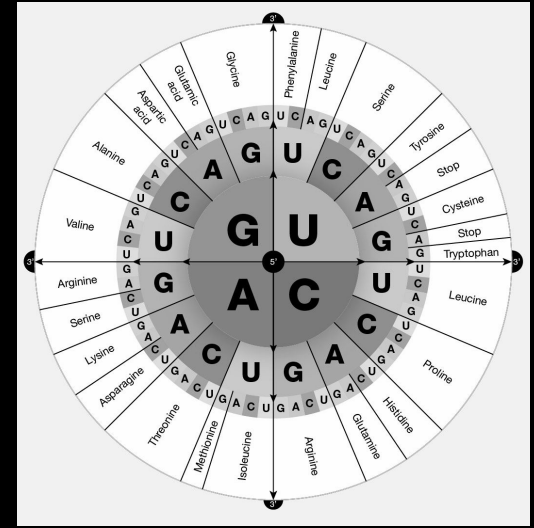
A •—	N —•
B —•••	O ———
C —•—••	P —•—•
D —•••	Q —•—•—
E •	R •—••
F —•—••	S —•••
G —•—•	T —
H ••••	U ••—
I ••	V ••—•
J —•—•—	W ••—•
K —•—•	X —•••—
L —••••	Y —••—•
M —•—	Z —••••
1 •—•—•—	6 —•••••
2 ••—•—•—	7 —••••••
3 •••—•—•	8 —•—••••
4 ••••—•—	9 —•—•—••
5 ••••••	0 —•—•—•—

© Radio Society of Great Britain

e)



f)



ANALOG VS. DIGITAL

where can you stand on each side?



where can you stand on each side?



where can you stand on each side?



where can you stand on each side?



where can you stand on each side?

CONTINUOUS



analog and digital clocks



Image source: [Wikipedia](#)



Image source: [Wikipedia](#)

“Digitization is the representation of an object, image, sound, document or signal by generating a series of numbers that describe a discrete set of its points or samples”

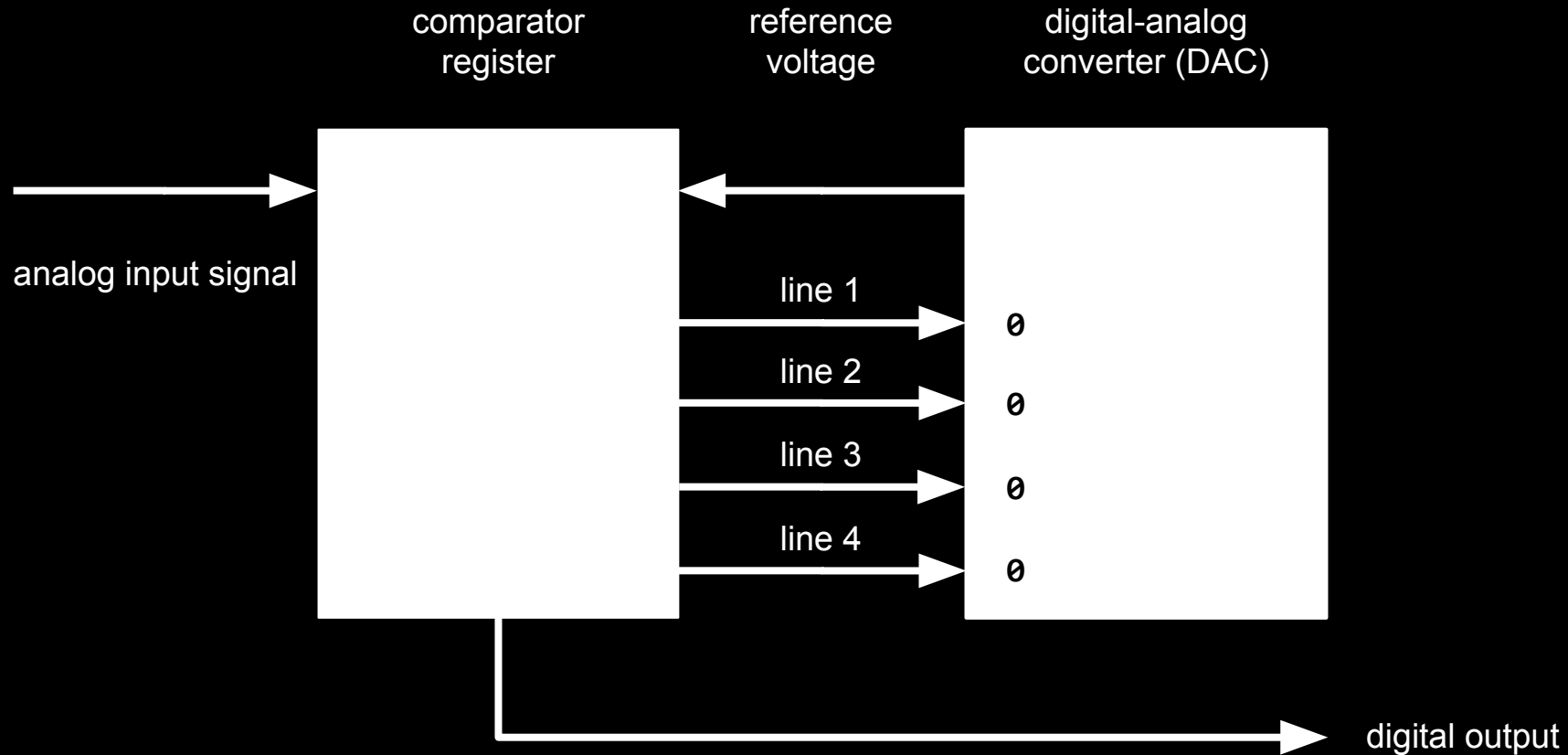
analog-to-digital converter (ADC)

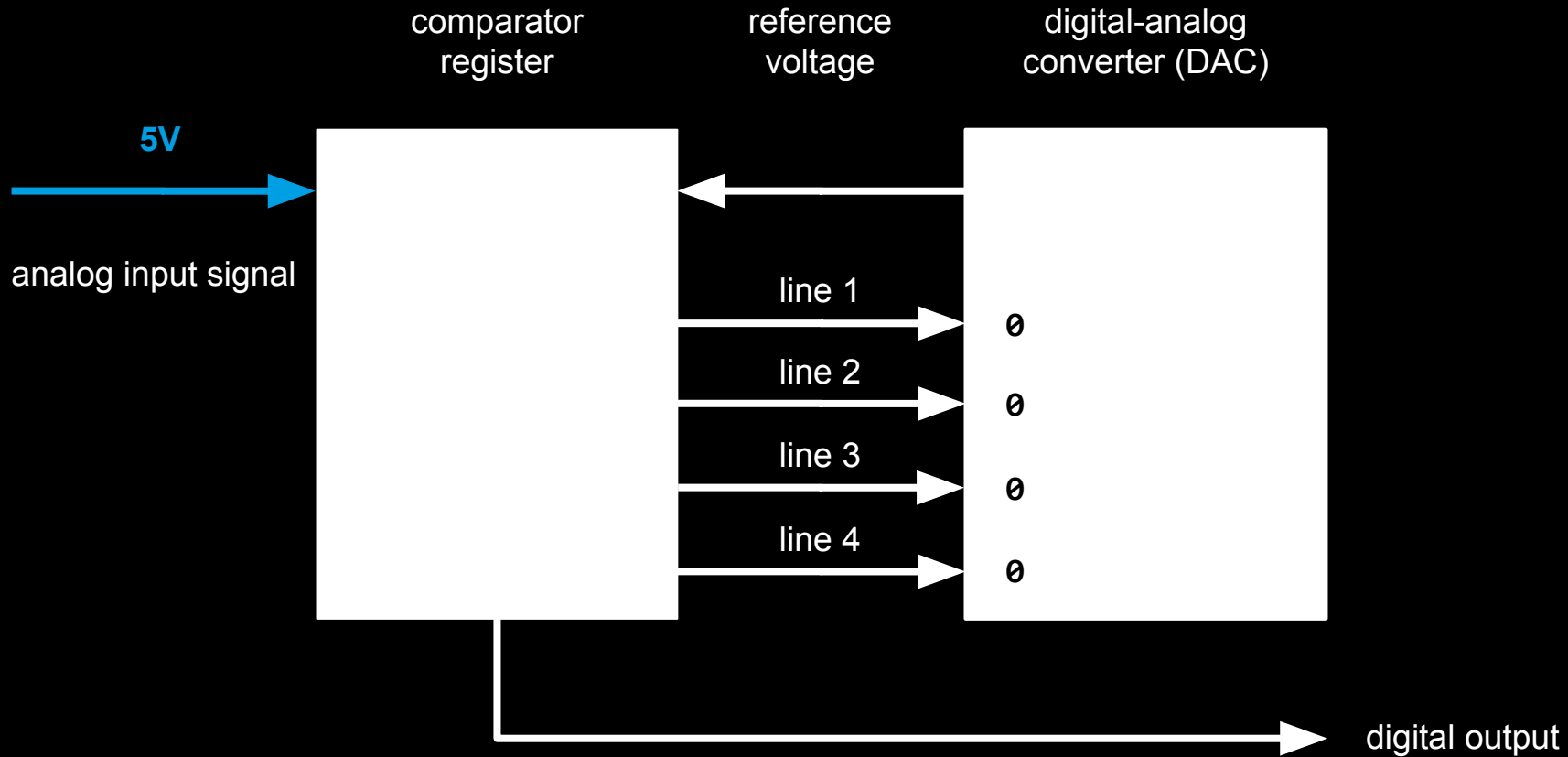


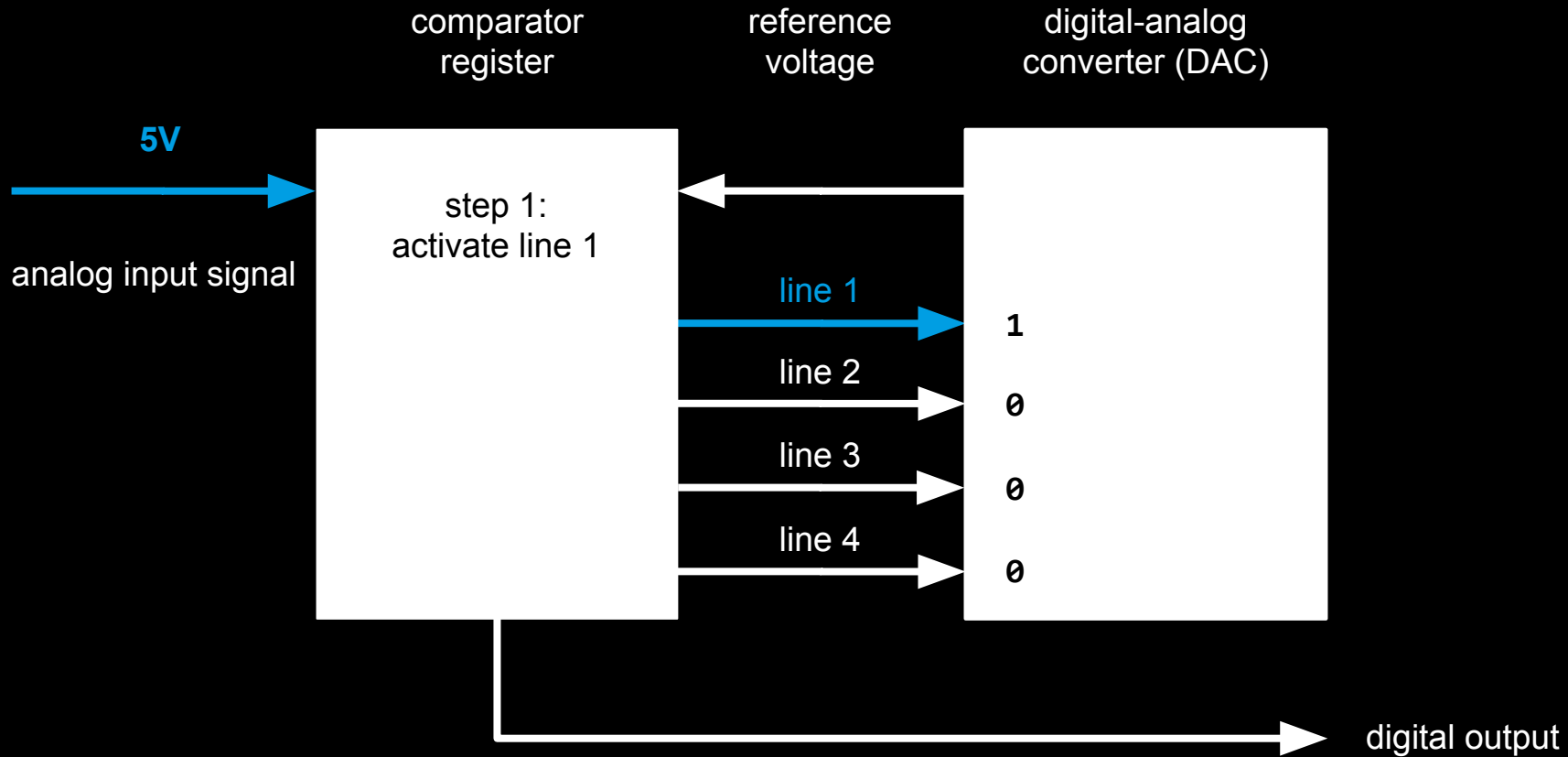
measuring of the
analog signal

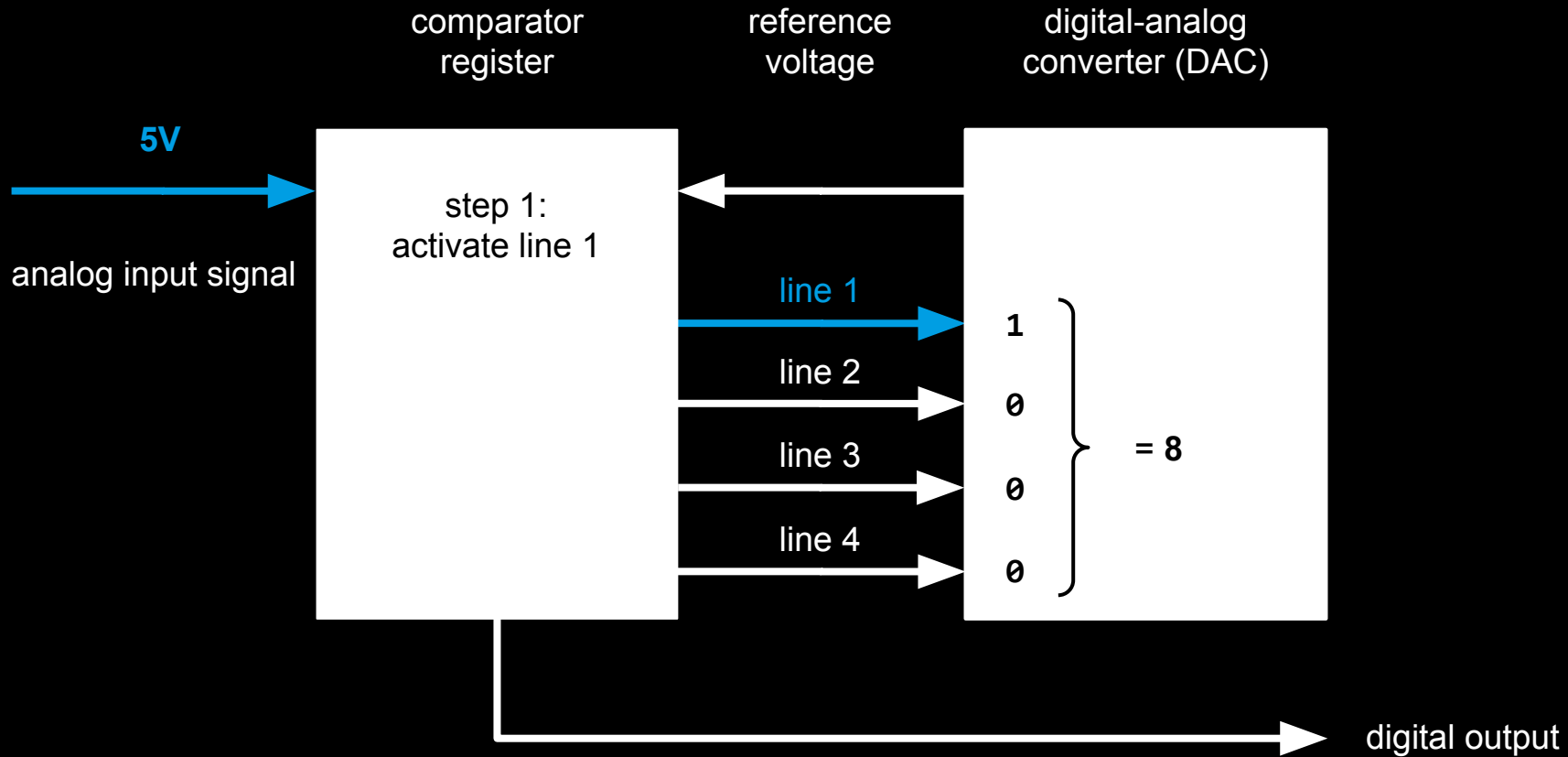
turning the
measurement into a
series of 1 and 0

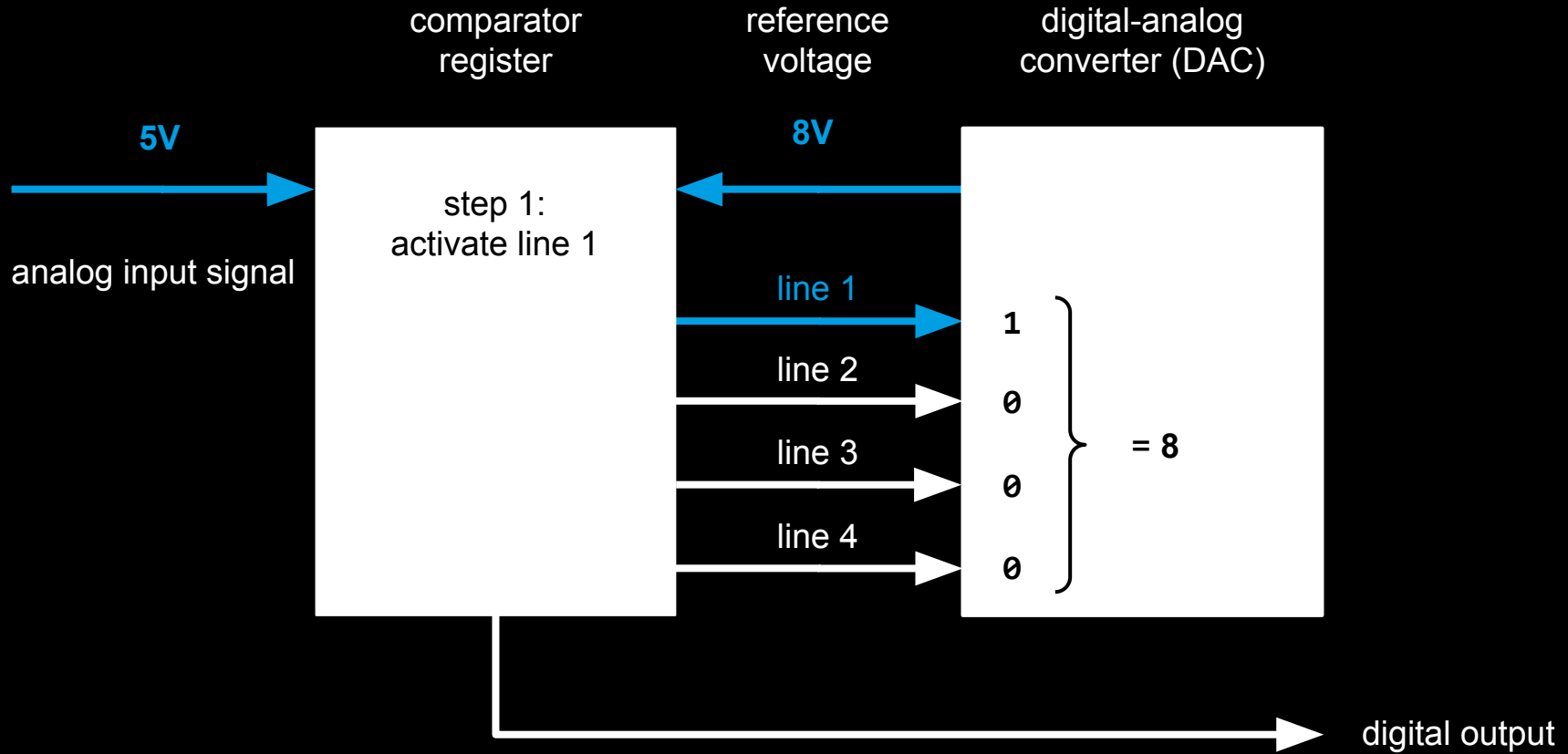
encoding the series of
numbers in binary
and assign meaning

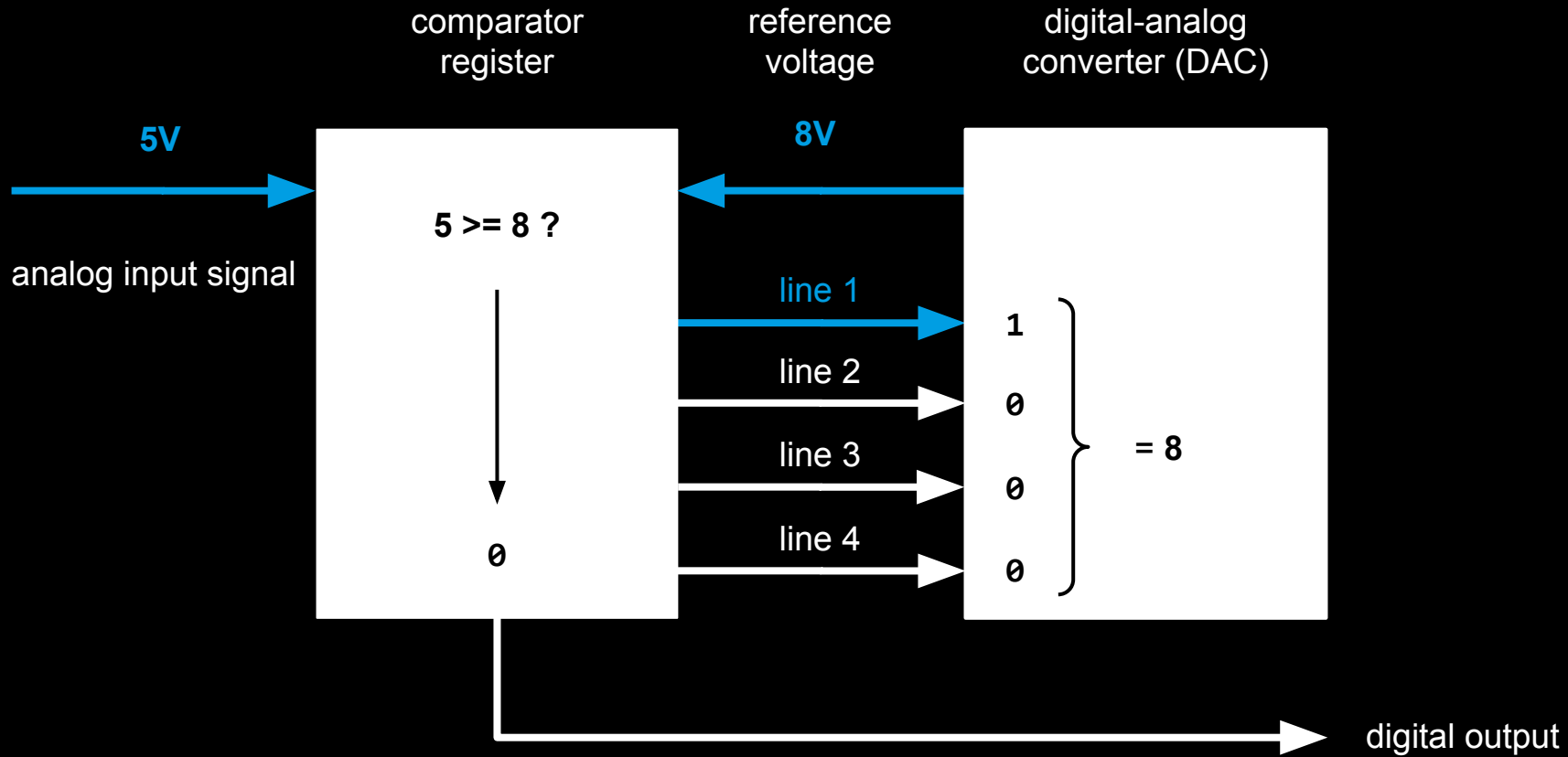


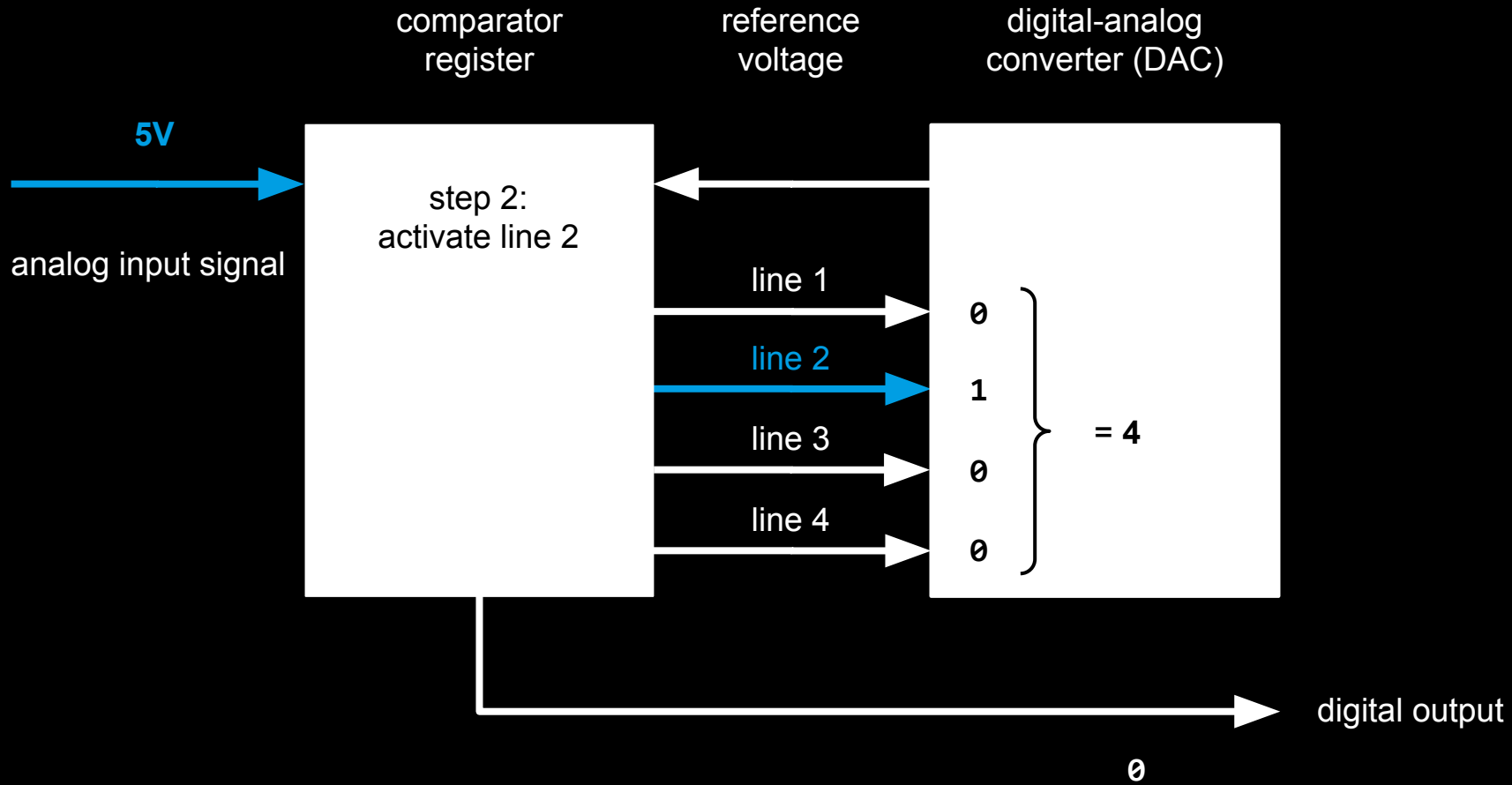


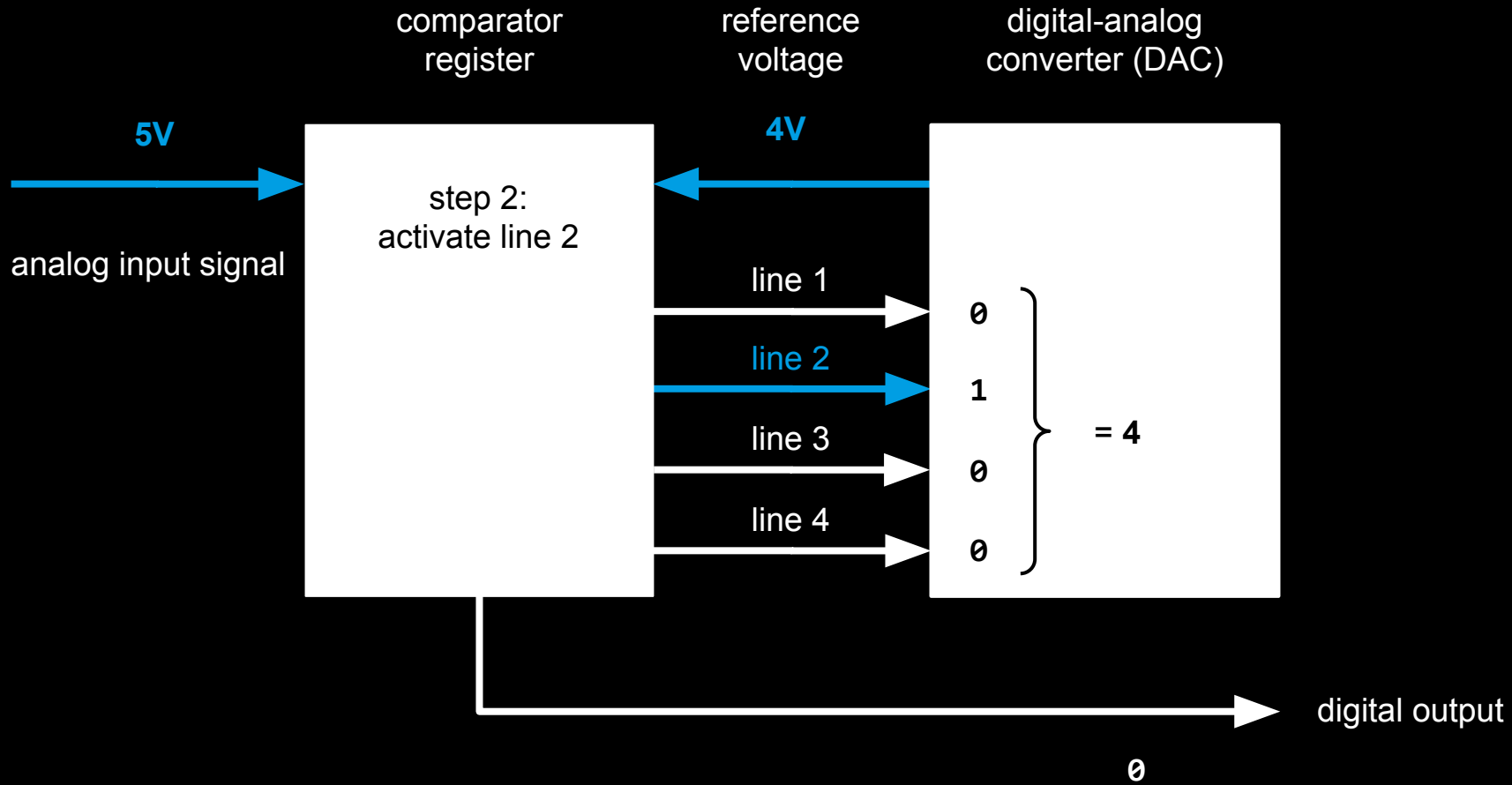


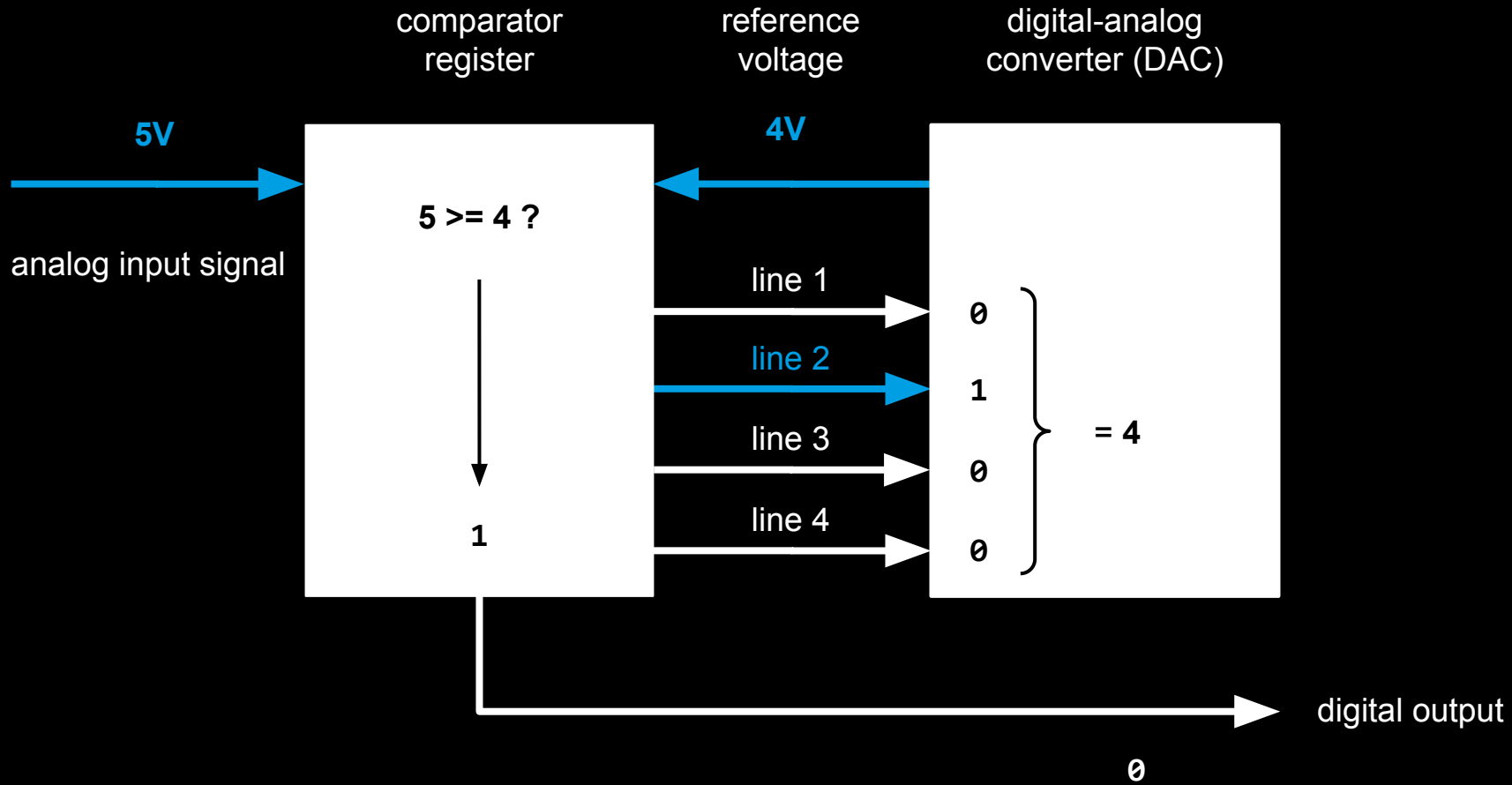


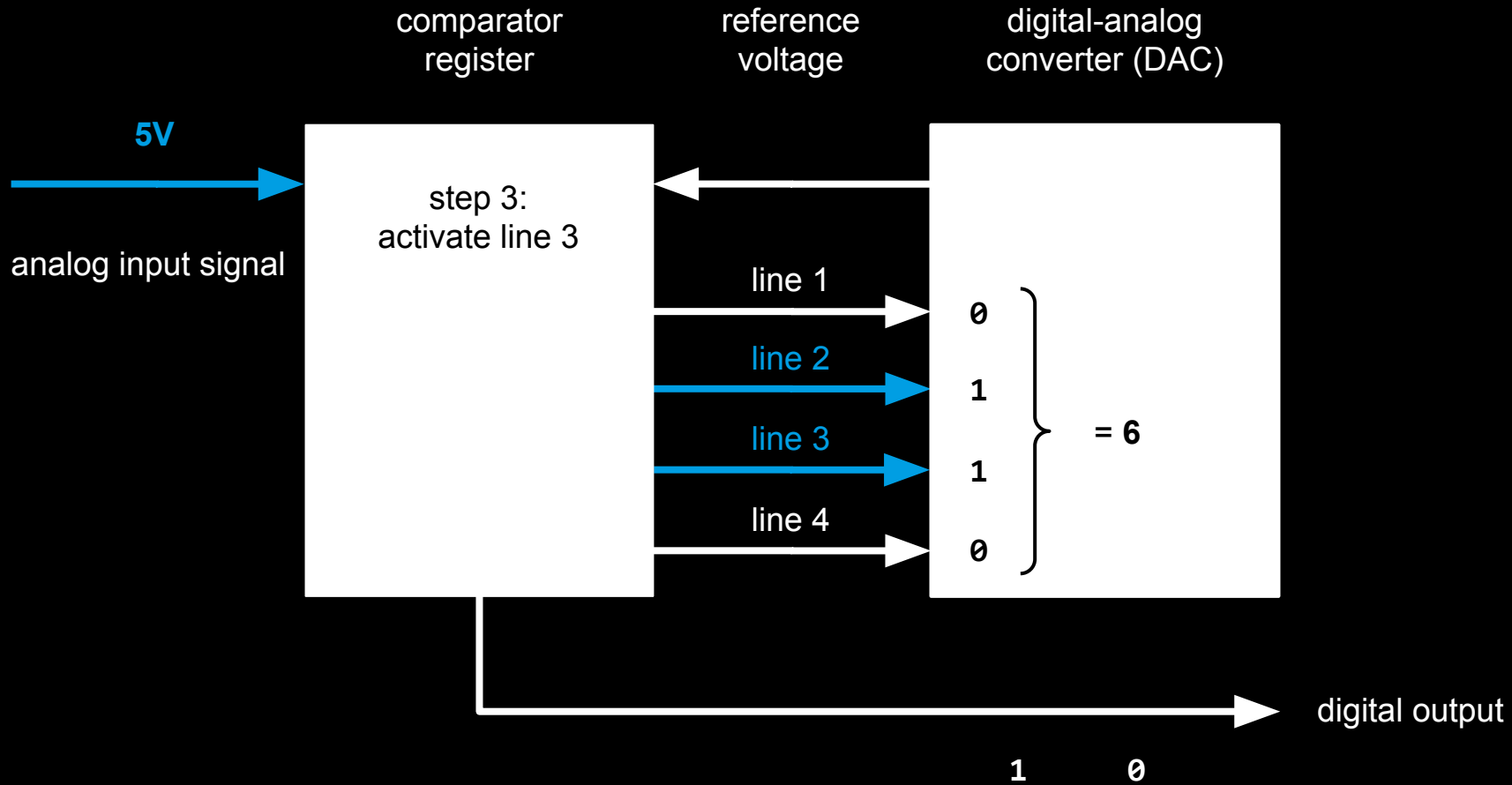


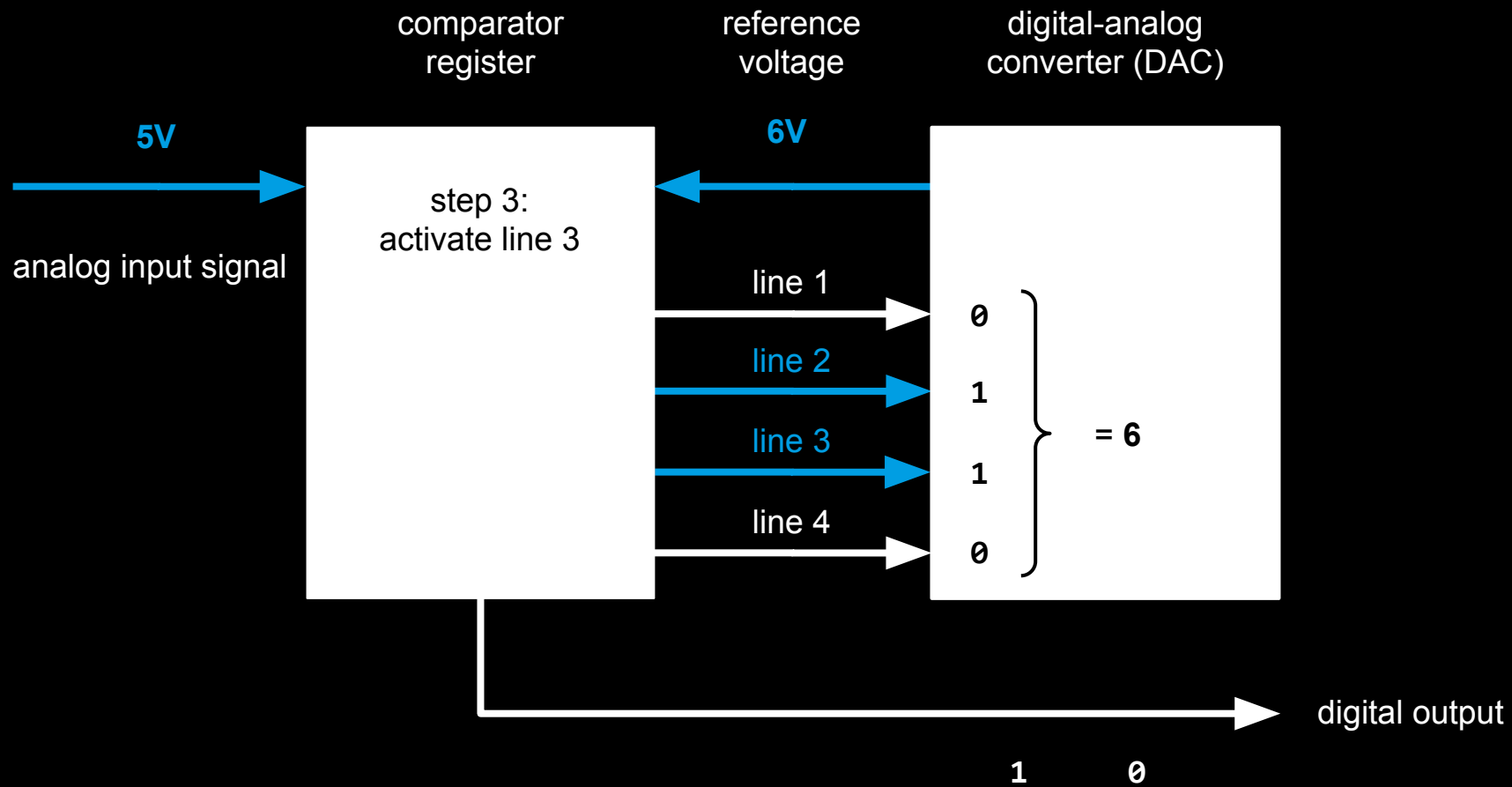


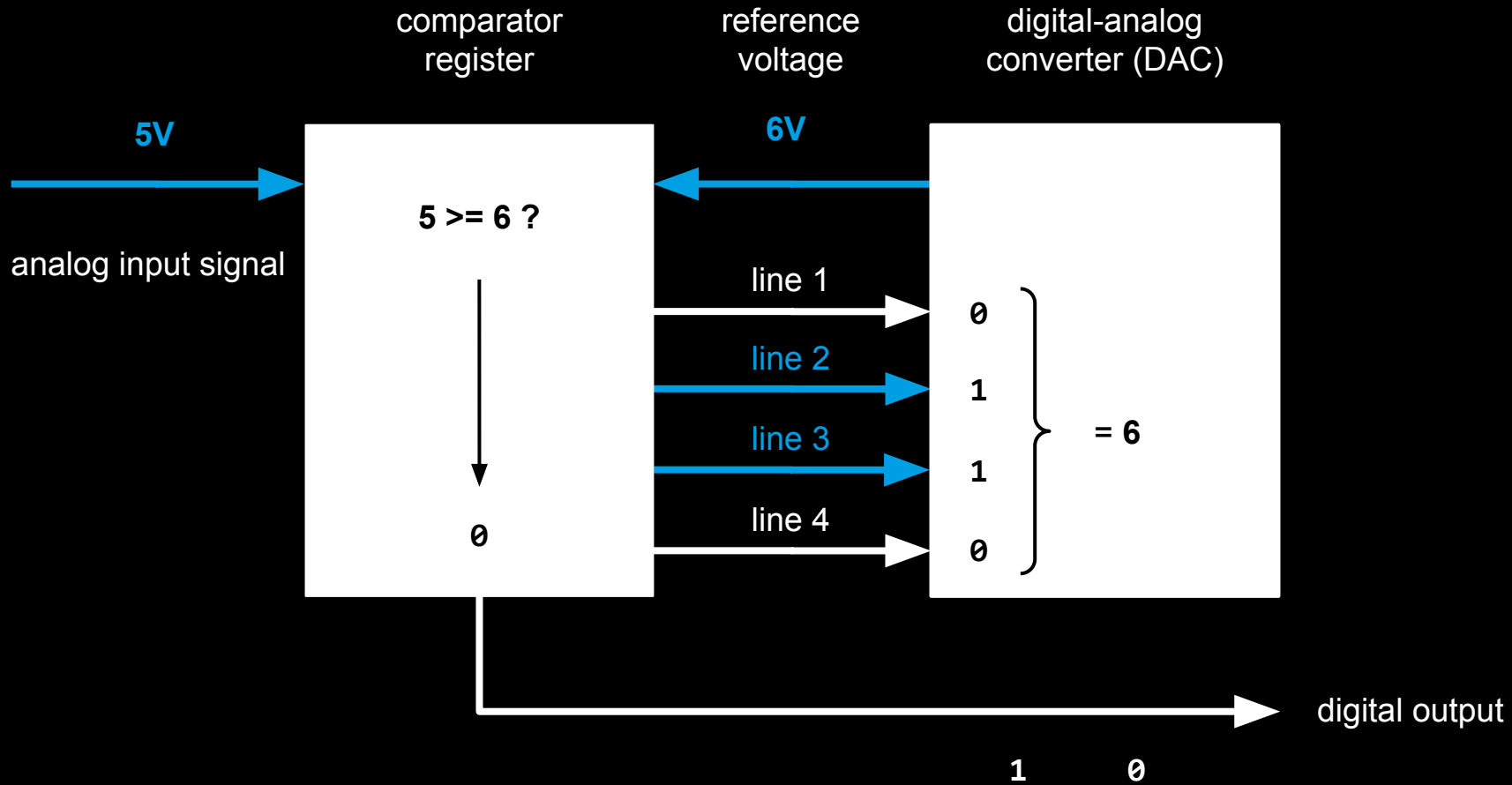


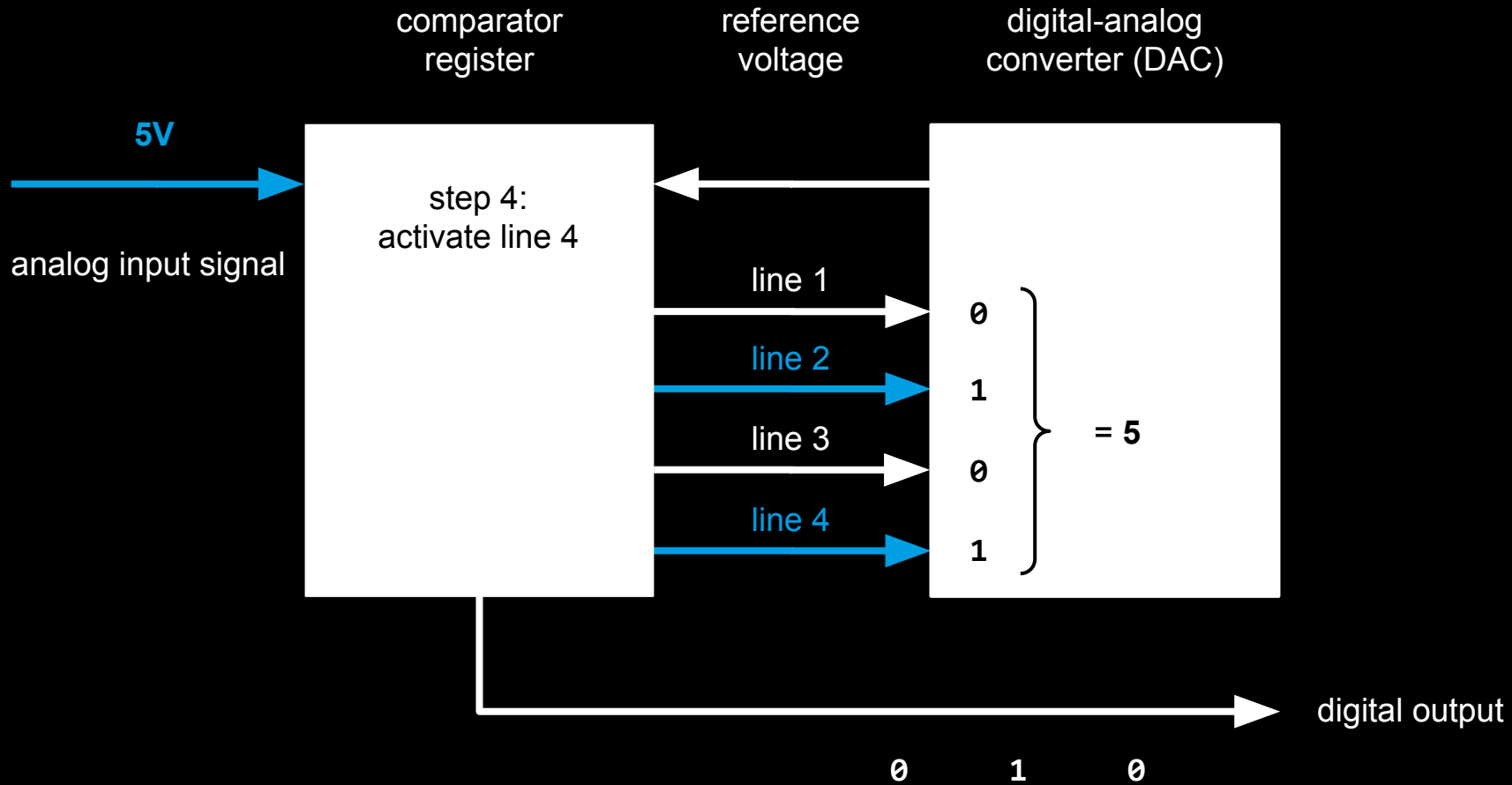


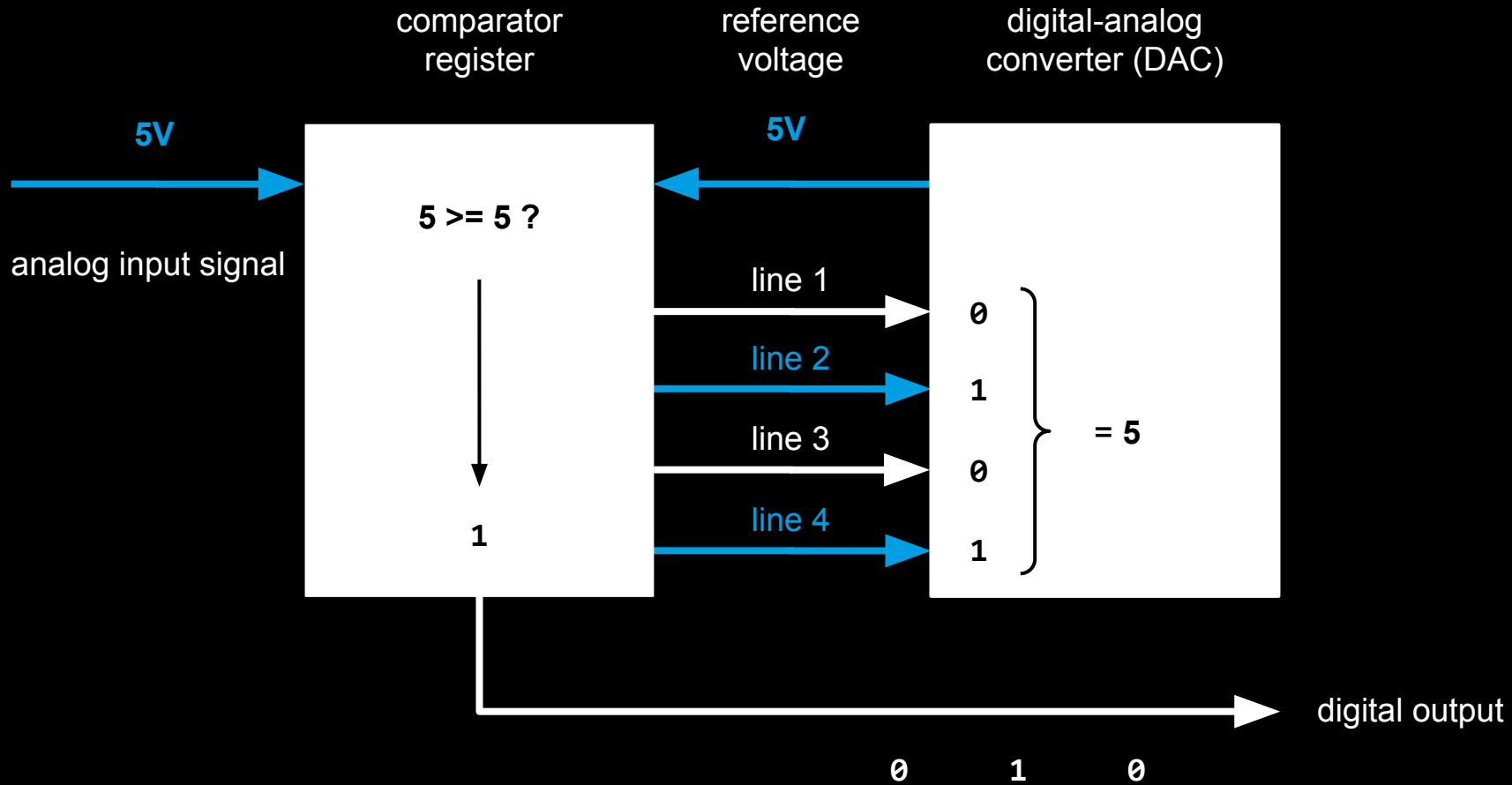


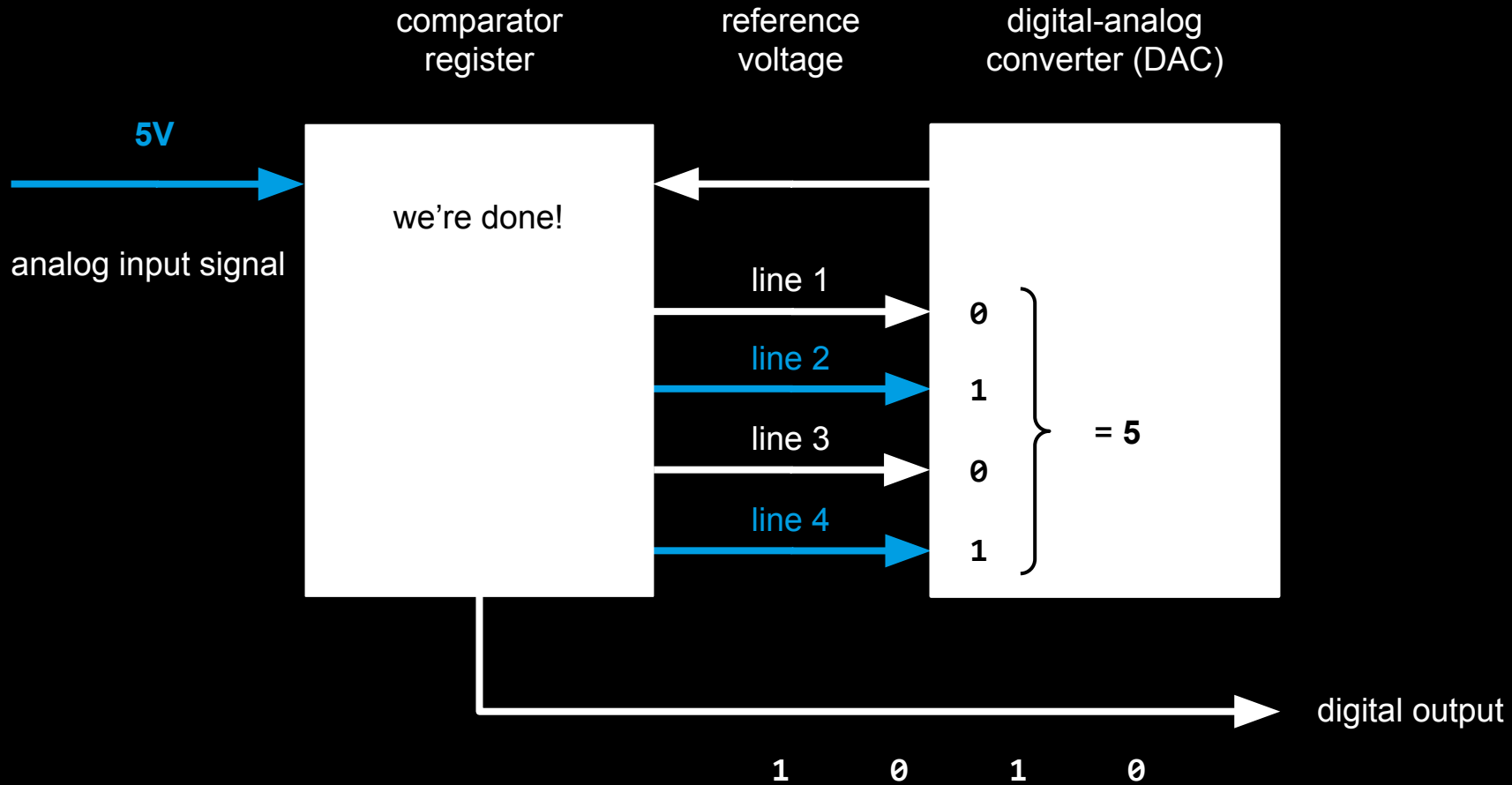






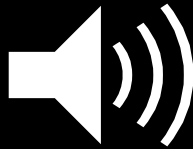






so, what analog signal is measured?





A **continuous** wave is transformed into an array of **discrete numbers** representing pressure.

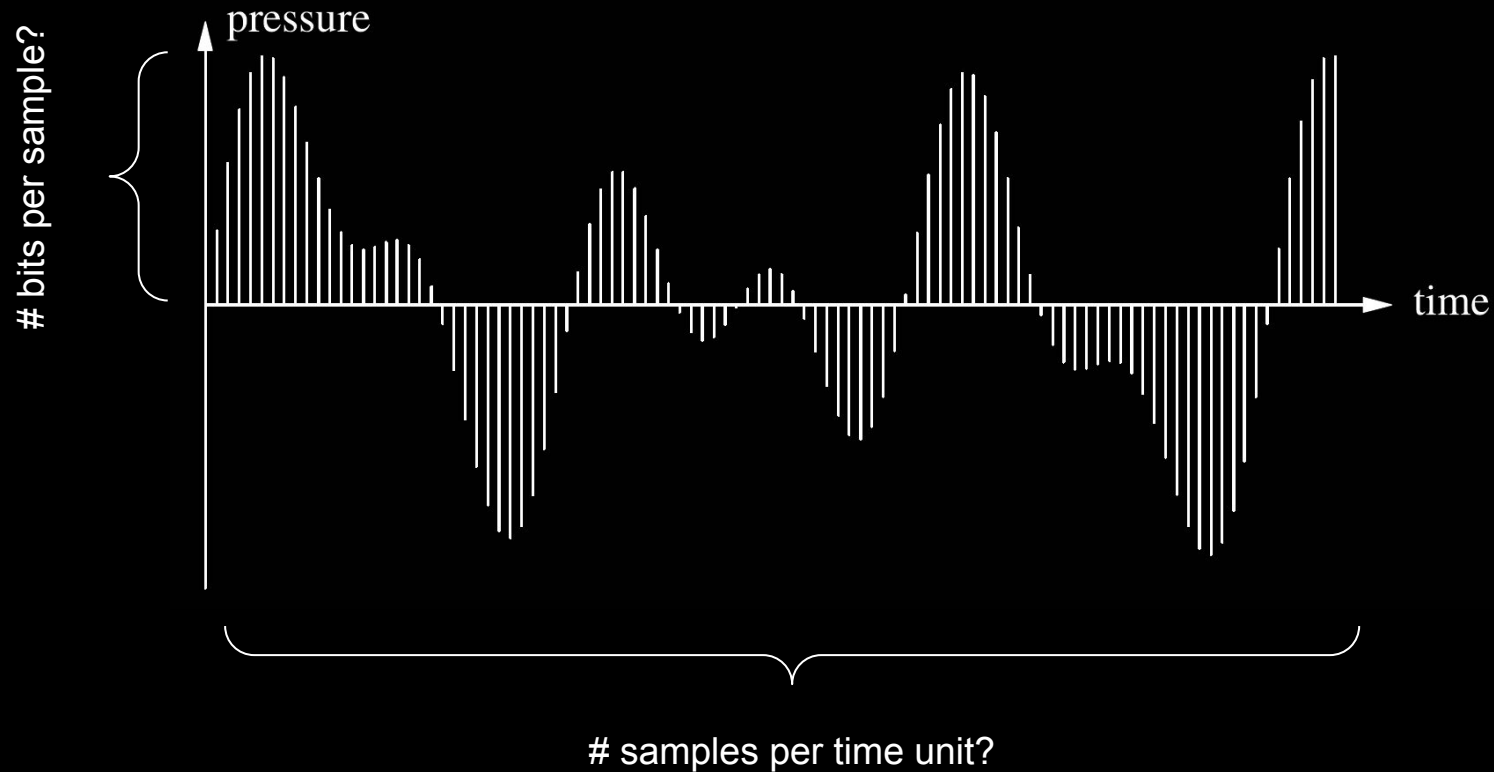




image sensor

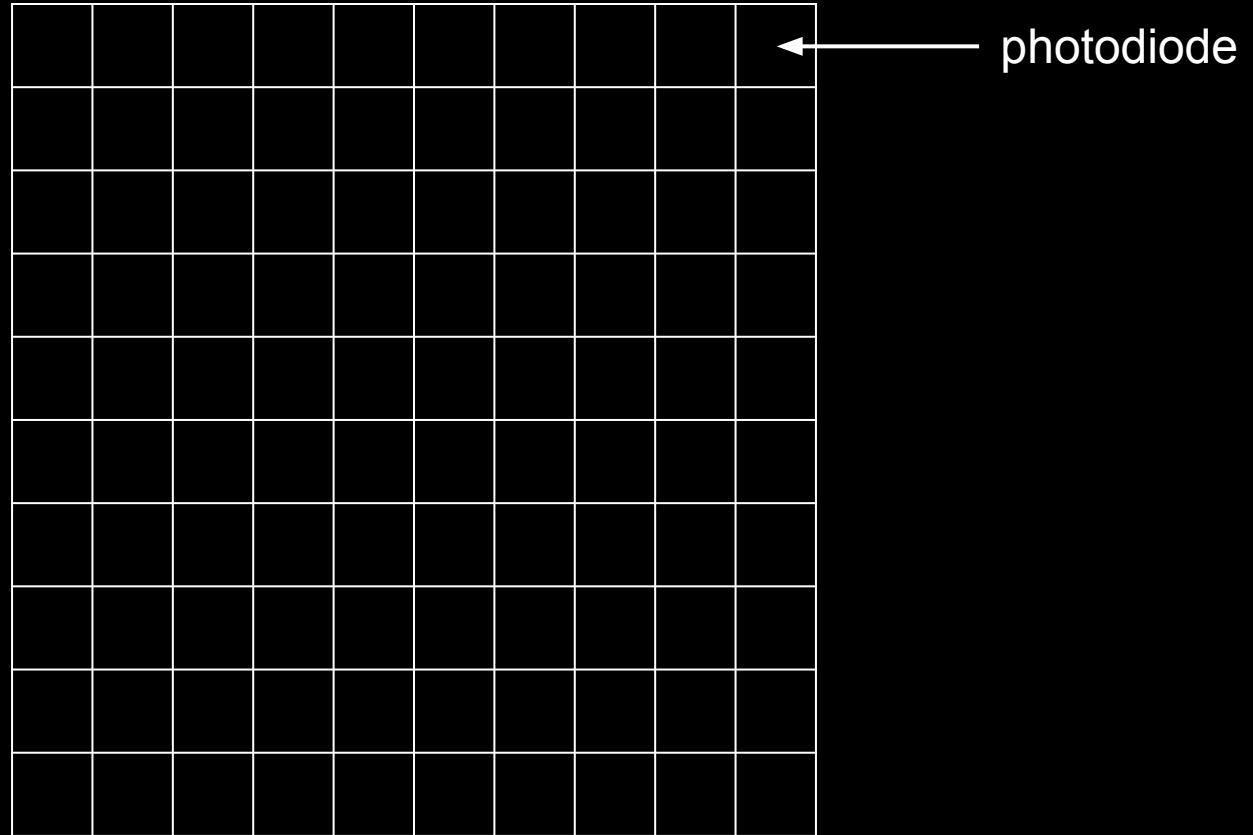
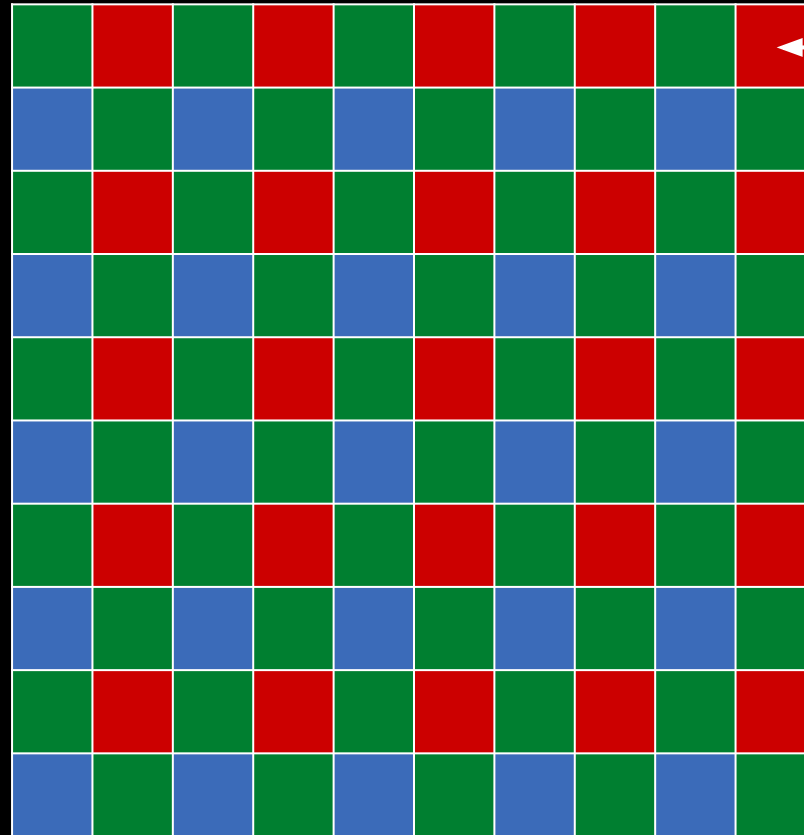


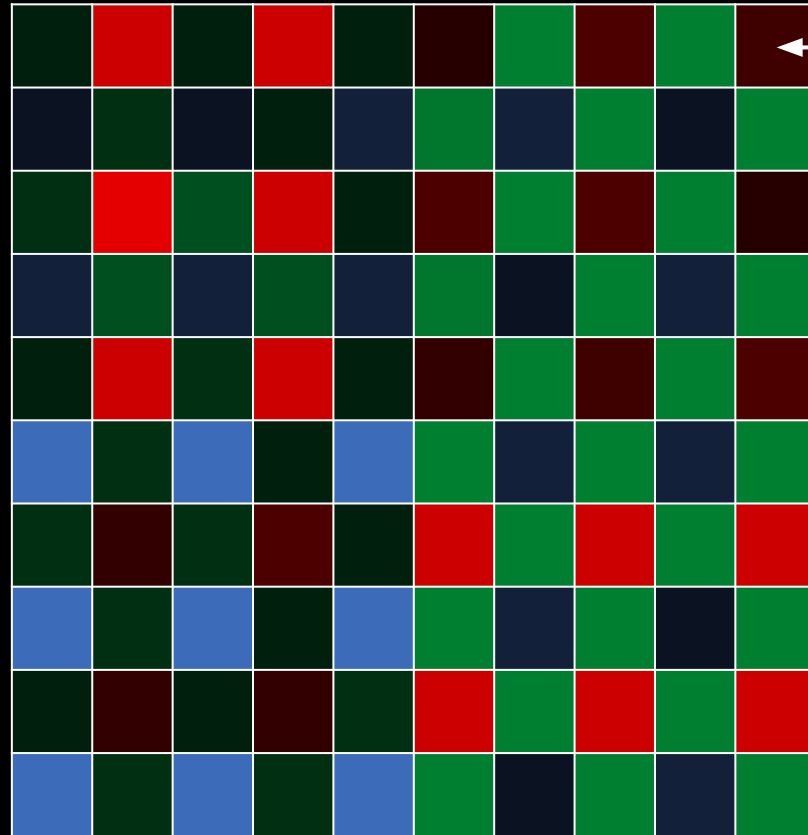
image sensor



color filter on
top of photo-
diodes

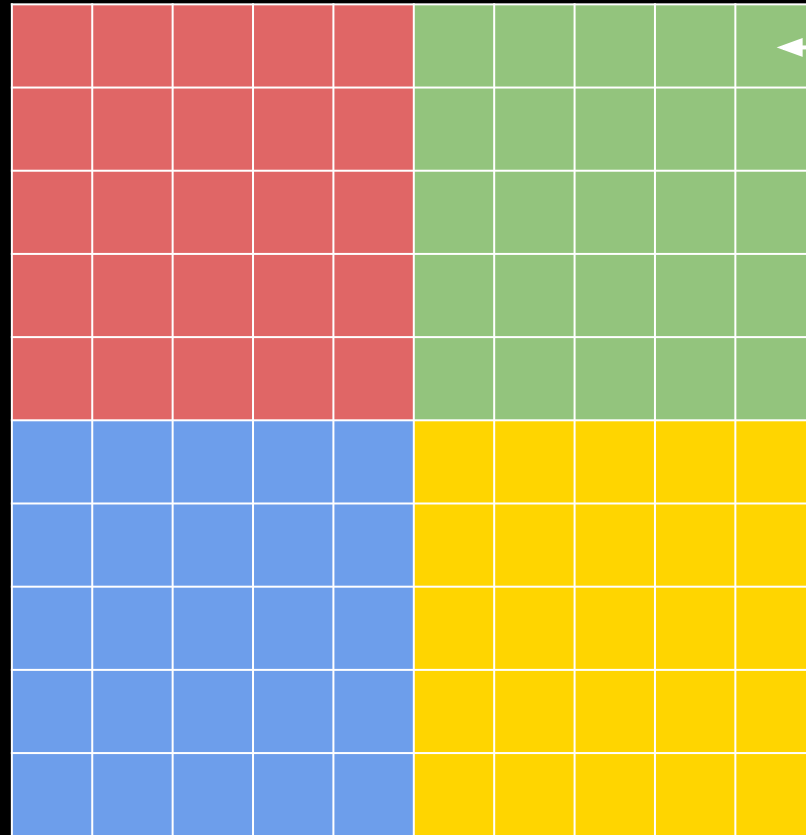


image sensor



light passed
through filter

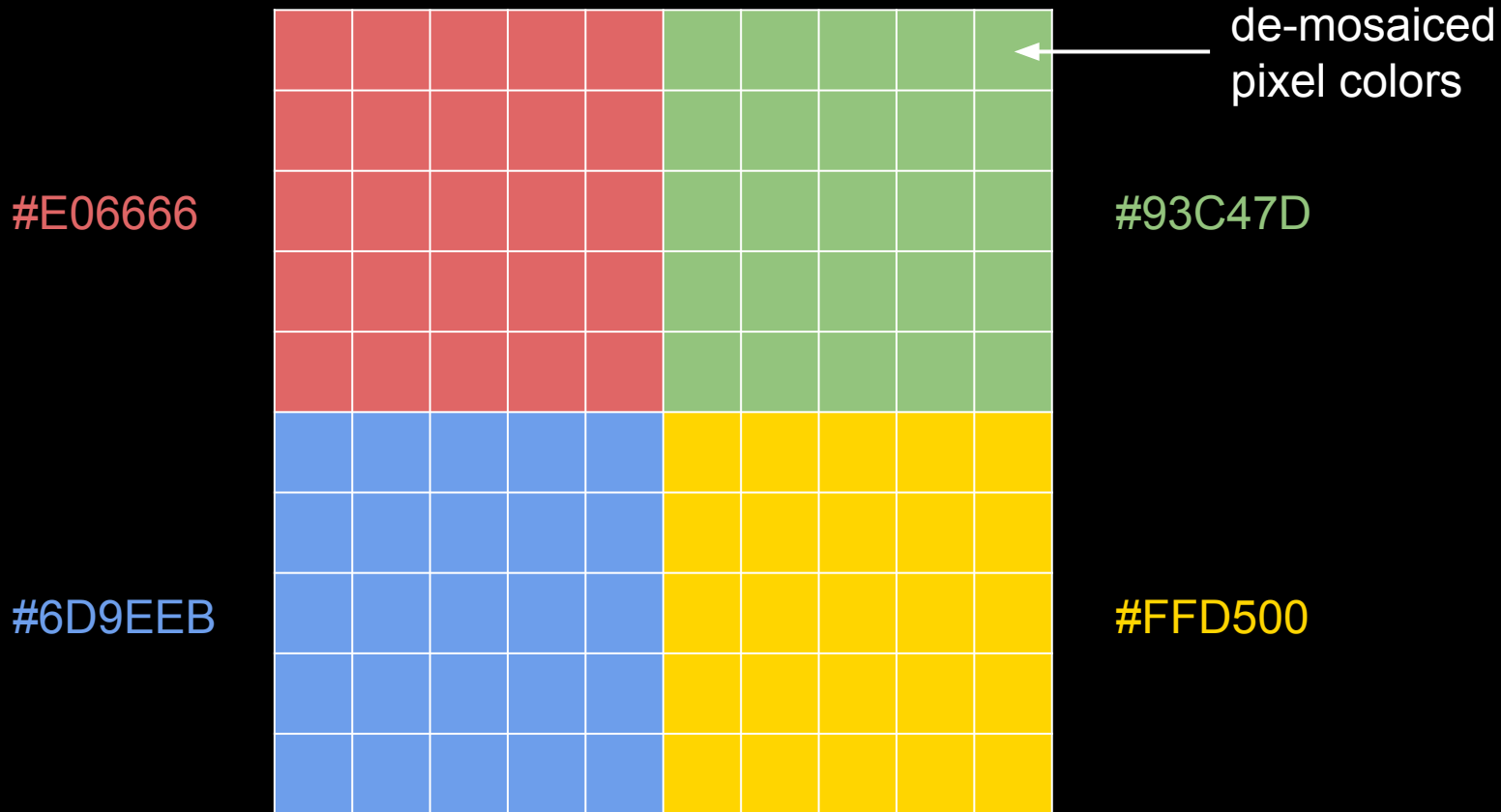
image sensor

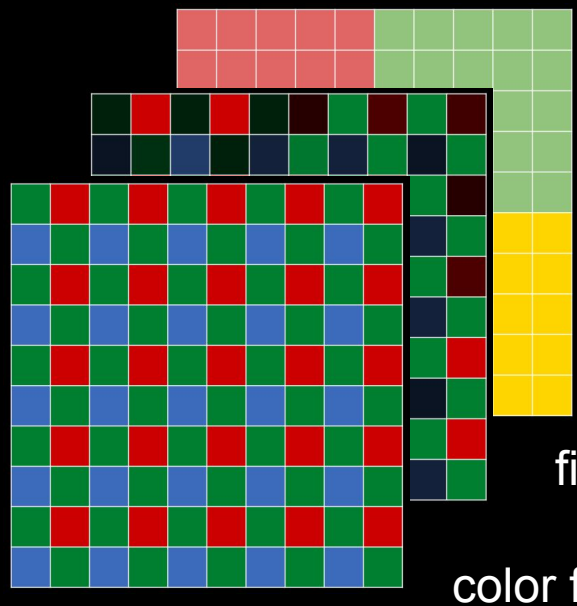


de-mosaiced
pixel colors



image sensor

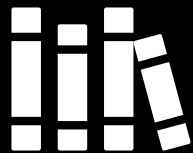




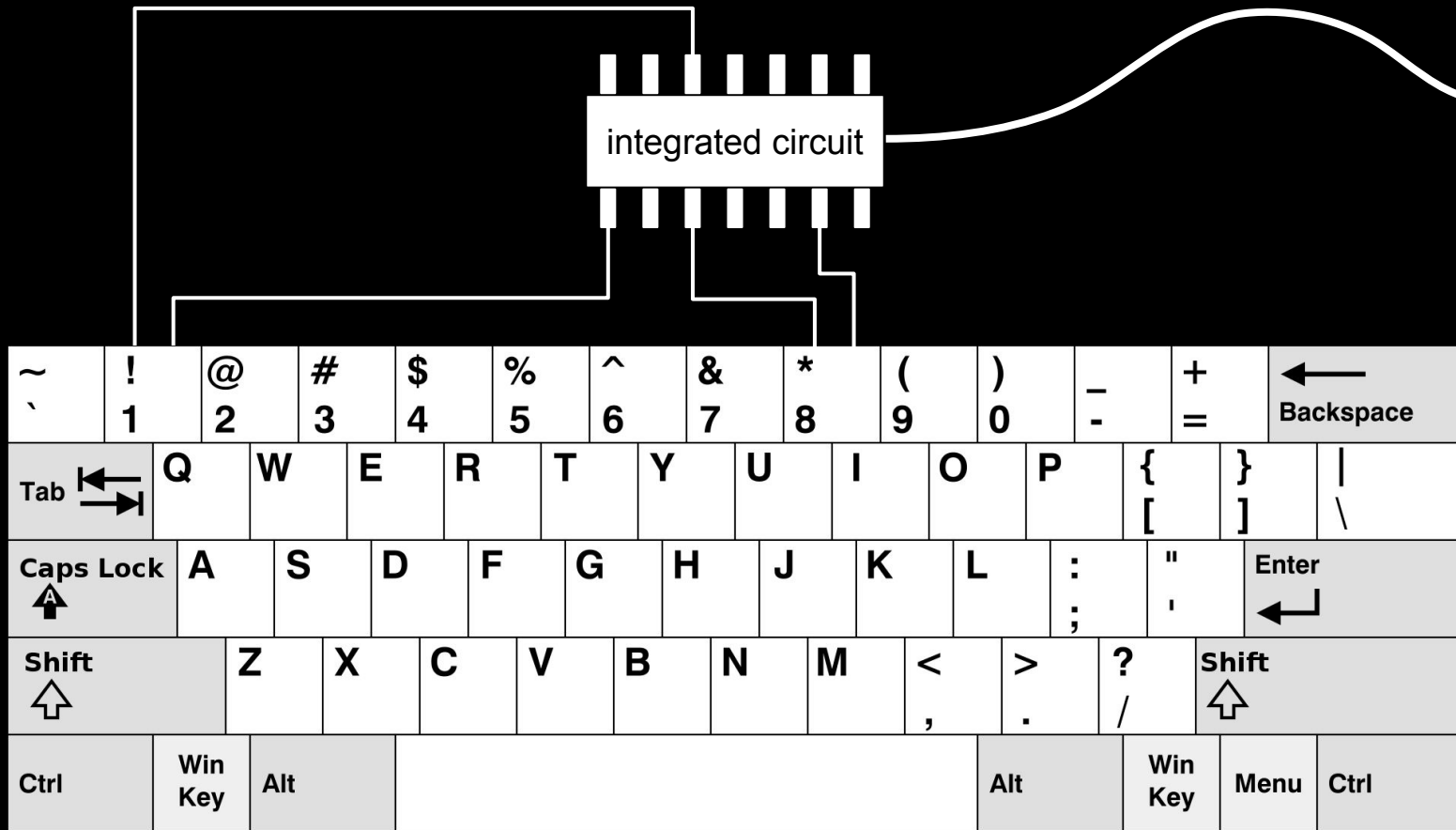
de-mosaiced pixel colors

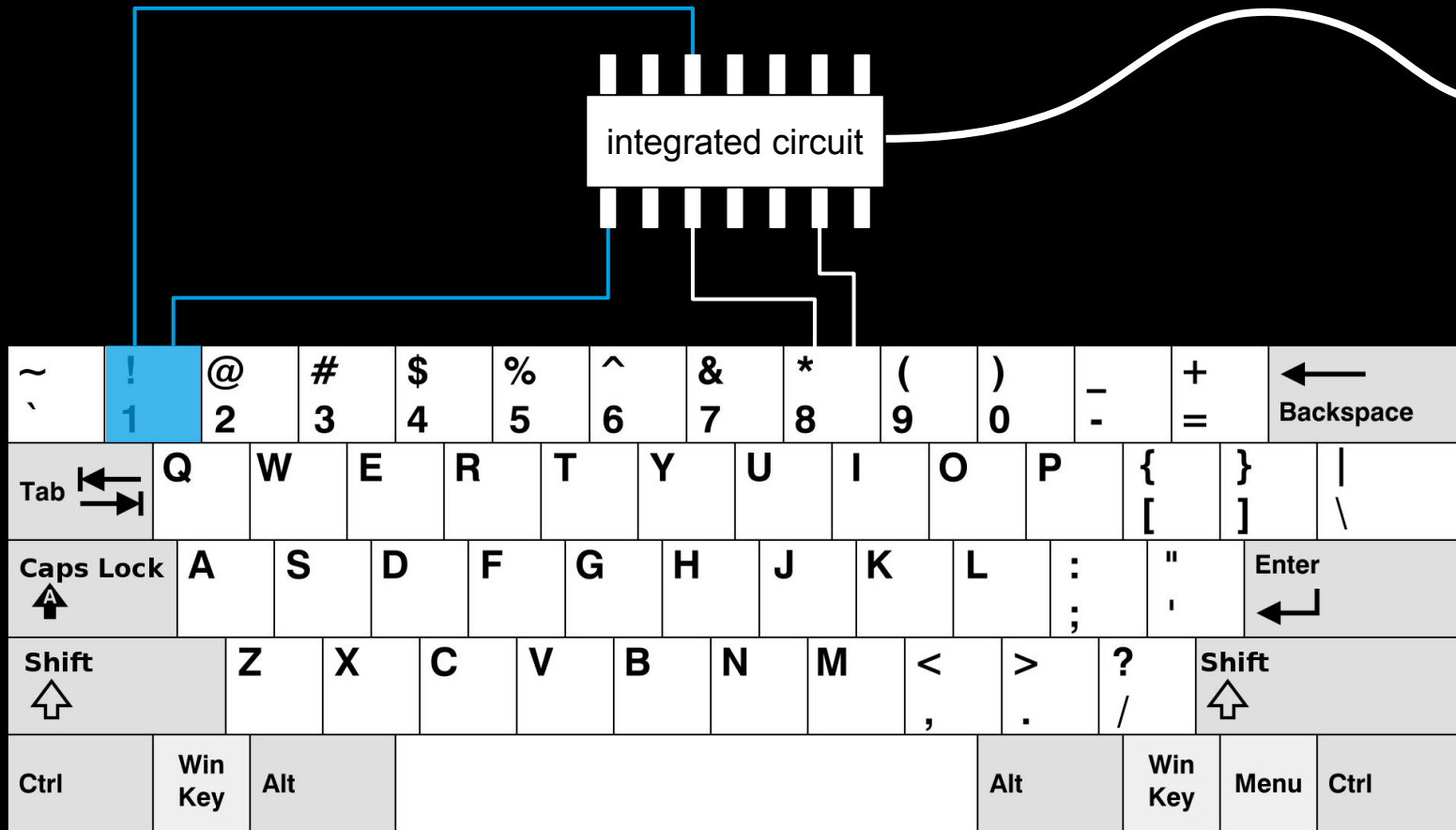
filtered light

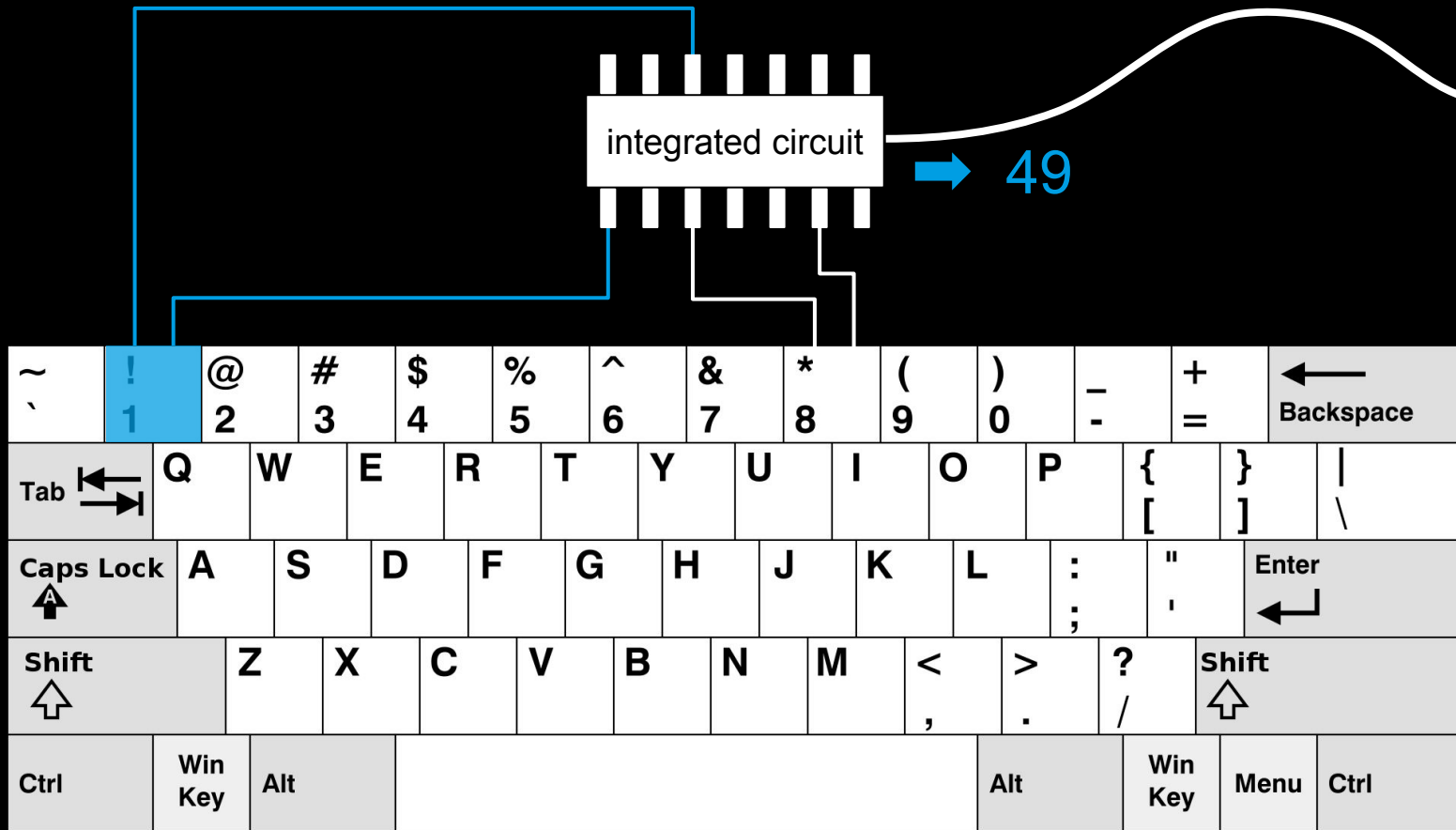
color filter

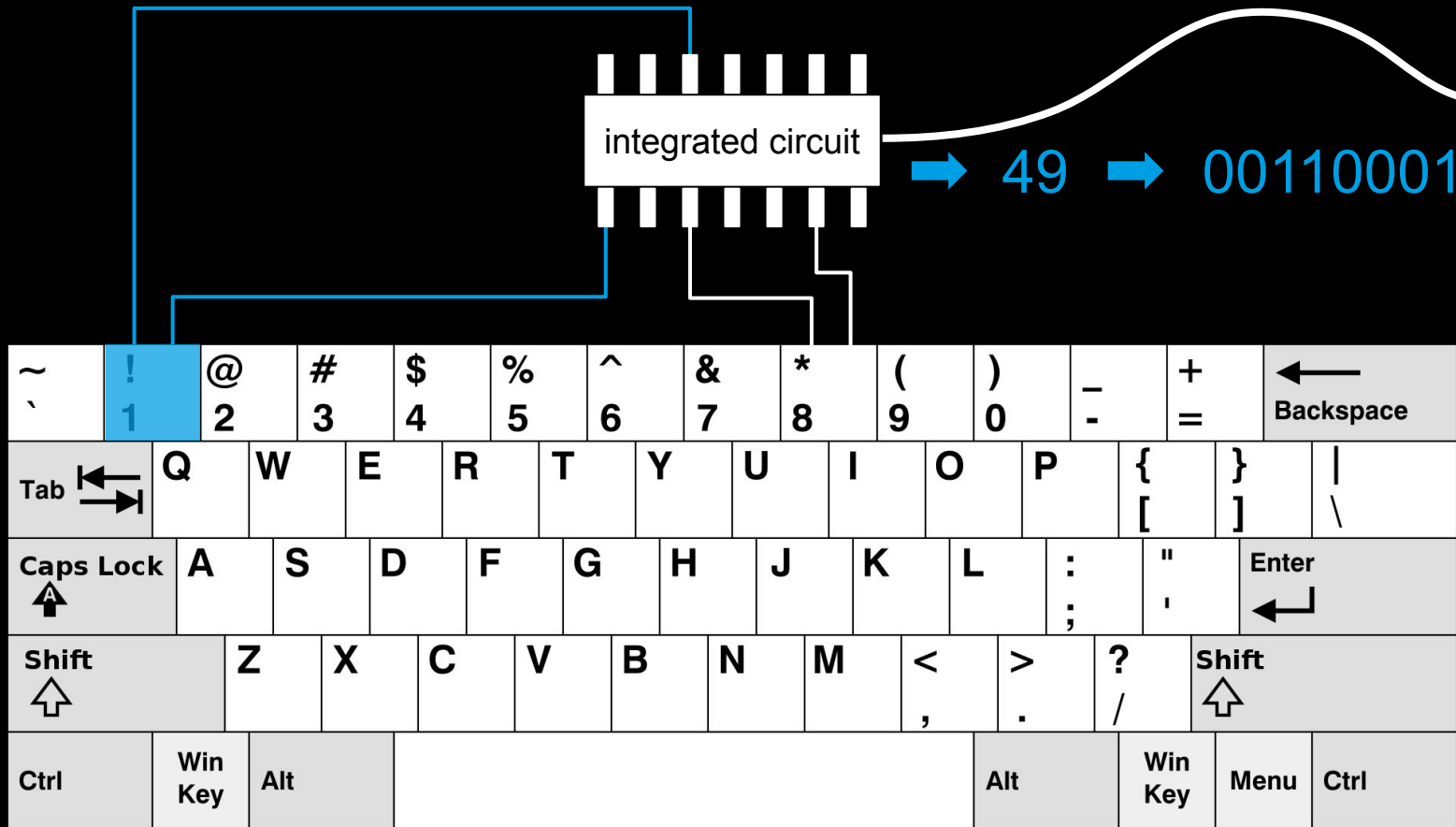


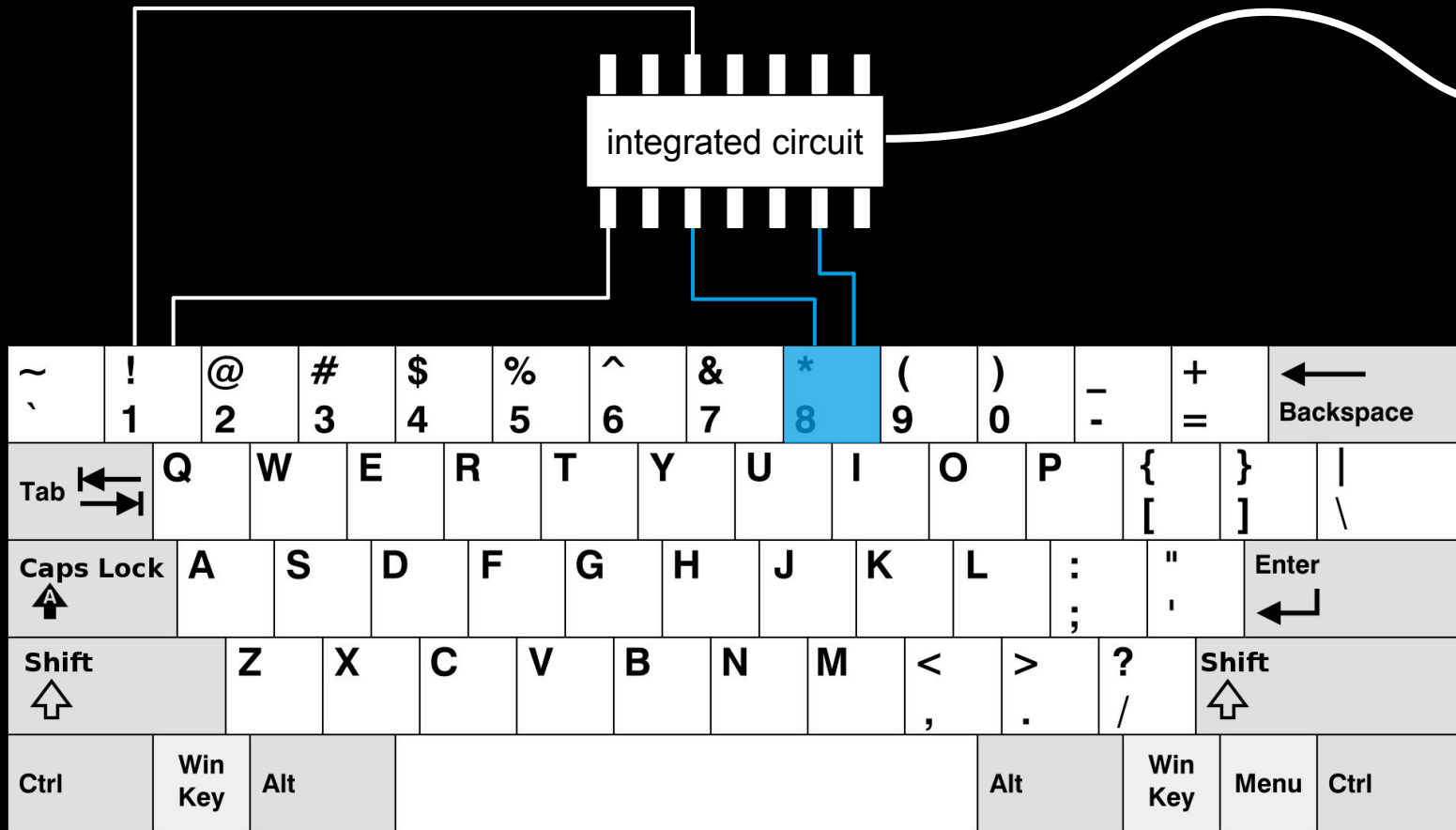
typing text

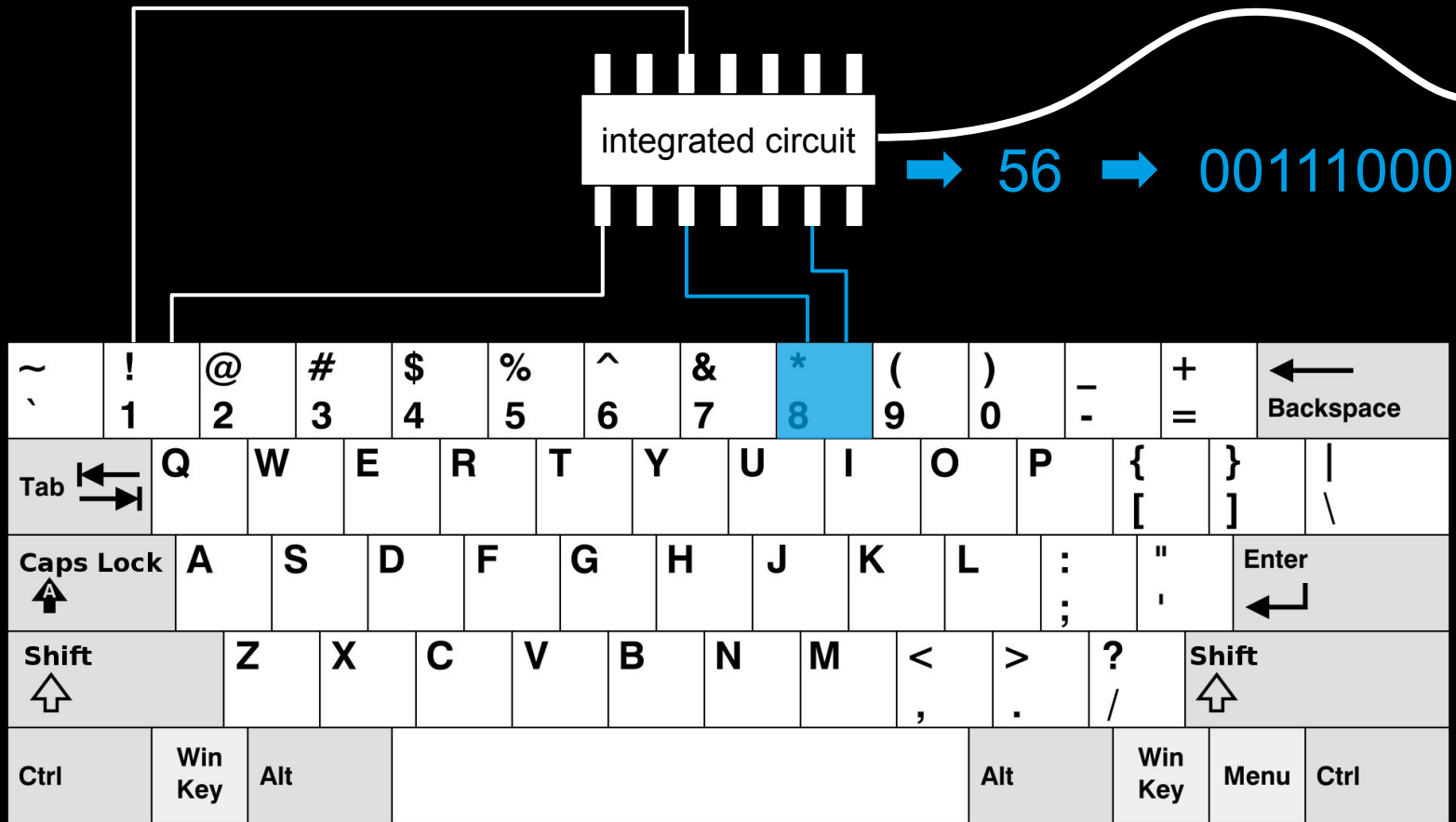










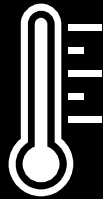


scanning text



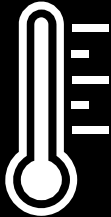
+

optical character recognition (OCR)



temperature sensor

A thermometer measures the temperature using a proxy, such as electrical resistance. The result is a change in voltage, which can be converted into a temperature.



```
1100 0101 1101 1110  
1001 0110 1111 0100  
0000 0111 1111 0001
```

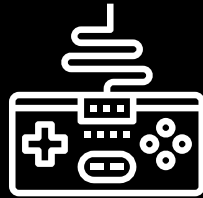




Image source: [Wikipedia](#)



Image source: [Wikipedia](#)

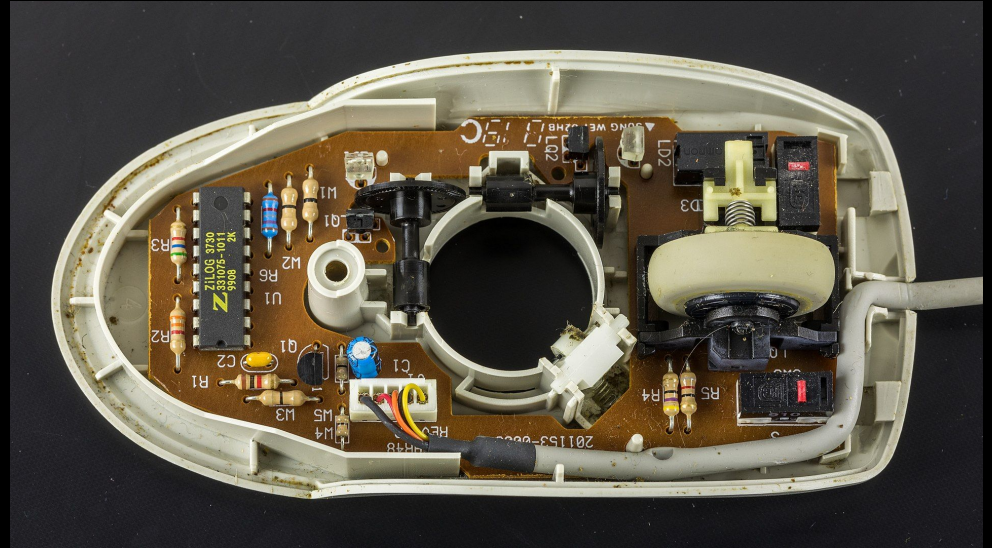


Image source: [Wikipedia](#)



Image source: [Wikipedia](#)

digital goods



Image source: [Wikipedia](#)

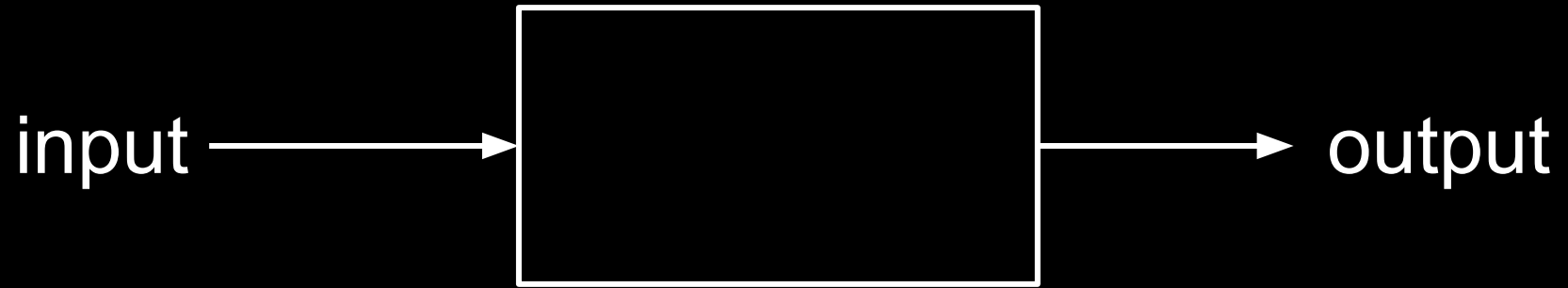


Image source: [Wikipedia](#)

computer processable
perfect reproduction
non-rival
near-zero costs of reproduction

ALGORITHMS

who solves the problem?





algorithm, program, process

"A finitely long rule consisting of individual instructions is called an **algorithm**."

Source: Vornberger, O., Algorithmen und Datenstrukturen, Lecture notes: <http://www-lehre.inf.uos.de/~ainf/2013/PDF/skript.pdf>

"A **program** is an algorithm expressed in a programming language."

Source: Vornberger, O., Algorithmen und Datenstrukturen, Lecture notes: <http://www-lehre.inf.uos.de/~ainf/2013/PDF/skript.pdf>

"A **process** is a program that is currently executed by a computer."

Source: Vornberger, O., Algorithmen und Datenstrukturen, Lecture notes: <http://www-lehre.inf.uos.de/~ainf/2013/PDF/skript.pdf>



greatest common divisor

euclidean algorithm

Identify the larger number. If $a < b$, swap numbers so that $a > b$

Subtract b from a and replace a with the result

Repeat until one of the numbers becomes 0

Return the number that is not zero

Loop 1:

a = 18, b = 48 → swap

Loop 1:

$a = 18, b = 48 \rightarrow \text{swap} \rightarrow a = 48, b = 18$

$a = 48 - 18 = 30$

Loop 1:

$a = 18, b = 48 \rightarrow \text{swap} \rightarrow a = 48, b = 18$

$a = 48 - 18 = 30$

Loop 2:

$a = 30, b = 18 \rightarrow \text{no swap}$

$a = 30 - 18 = 12$

Loop 1:

$a = 18, b = 48 \rightarrow \text{swap} \rightarrow a = 48, b = 18$

$a = 48 - 18 = 30$

Loop 2:

$a = 30, b = 18 \rightarrow \text{no swap}$

$a = 30 - 18 = 12$

Loop 3:

$a = 12, b = 18 \rightarrow \text{swap} \rightarrow a = 18, b = 12$

$a = 18 - 12 = 6$

Loop 1:

$a = 18, b = 48 \rightarrow \text{swap} \rightarrow a = 48, b = 18$

$a = 48 - 18 = 30$

Loop 2:

$a = 30, b = 18 \rightarrow \text{no swap}$

$a = 30 - 18 = 12$

Loop 3:

$a = 12, b = 18 \rightarrow \text{swap} \rightarrow a = 18, b = 12$

$a = 18 - 12 = 6$

Loop 4:

$a = 6, b = 12 \rightarrow \text{swap} \rightarrow a = 12, b = 6$

$a = 12 - 6 = 6$

Loop 1:

$a = 18, b = 48 \rightarrow \text{swap} \rightarrow a = 48, b = 18$

$a = 48 - 18 = 30$

Loop 2:

$a = 30, b = 18 \rightarrow \text{no swap}$

$a = 30 - 18 = 12$

Loop 3:

$a = 12, b = 18 \rightarrow \text{swap} \rightarrow a = 18, b = 12$

$a = 18 - 12 = 6$

Loop 4:

$a = 6, b = 12 \rightarrow \text{swap} \rightarrow a = 12, b = 6$

$a = 12 - 6 = 6$

Loop 5:

$a = 6, b = 6 \rightarrow \text{no swap}$

$a = 6 - 6 = 0$

Loop 1:

$a = 18, b = 48 \rightarrow \text{swap} \rightarrow a = 48, b = 18$

$a = 48 - 18 = 30$

Loop 2:

$a = 30, b = 18 \rightarrow \text{no swap}$

$a = 30 - 18 = 12$

Loop 3:

$a = 12, b = 18 \rightarrow \text{swap} \rightarrow a = 18, b = 12$

$a = 18 - 12 = 6$

Loop 4:

$a = 6, b = 12 \rightarrow \text{swap} \rightarrow a = 12, b = 6$

$a = 12 - 6 = 6$

Loop 5:

$a = 6, b = 6 \rightarrow \text{no swap}$

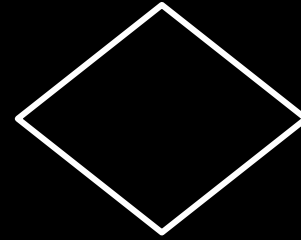
$a = 6 - 6 = 0$

return $b = 6$

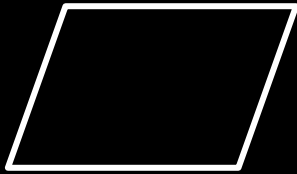
flow diagrams



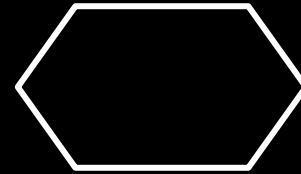
start / end of
algorithm



decision



input / output



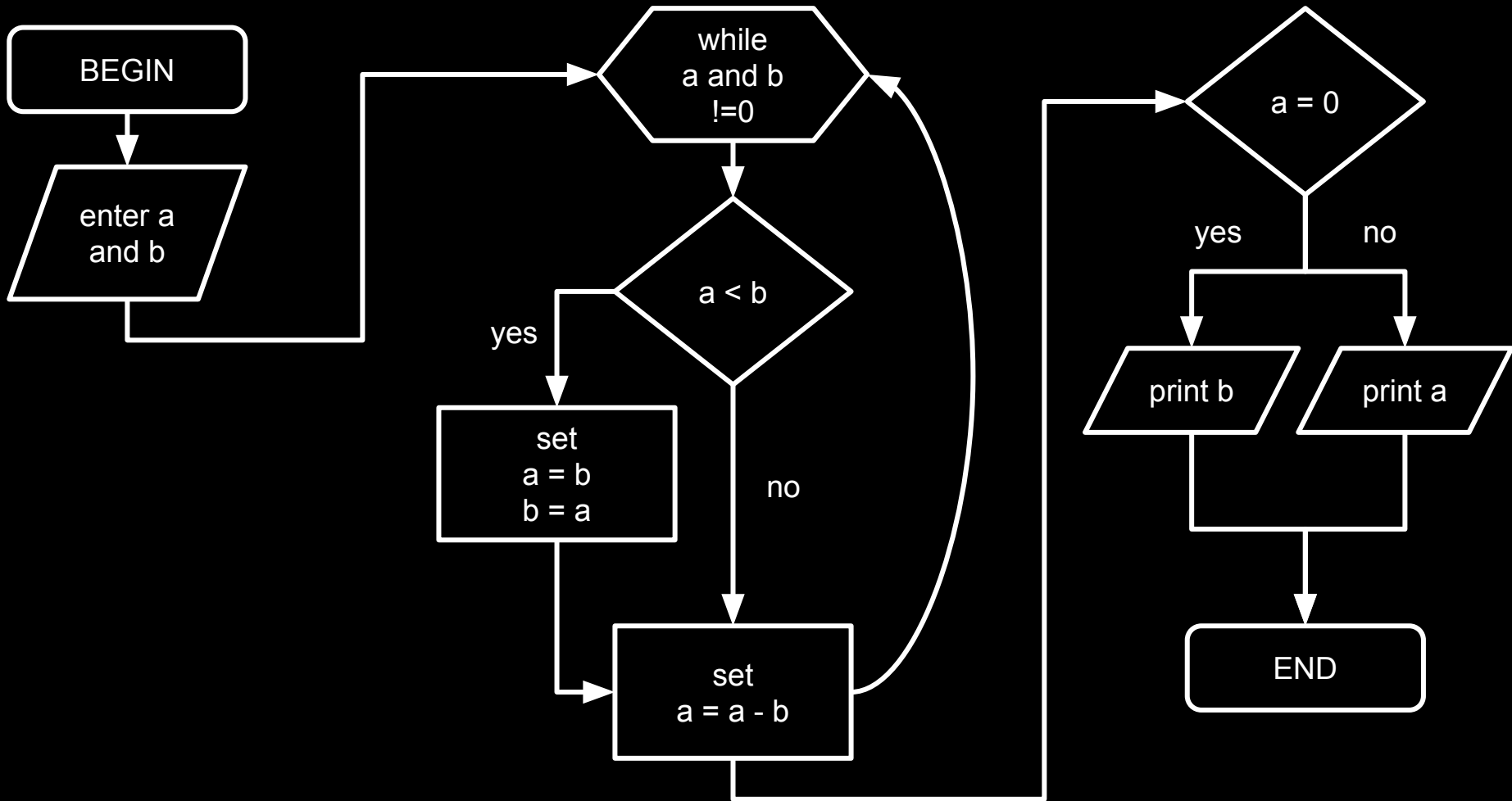
repetition



command /
assignment



external routine





square roots

babylonian method

calculate square root of
 $x = 16$

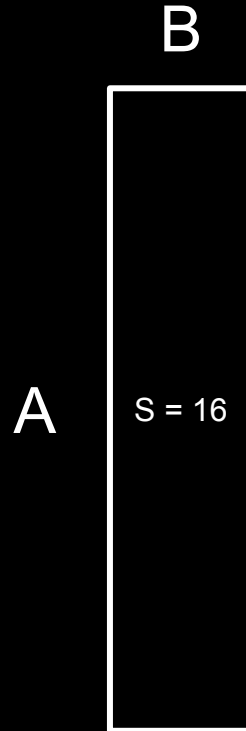
$$A = 1$$

$$B = X / A = 16$$



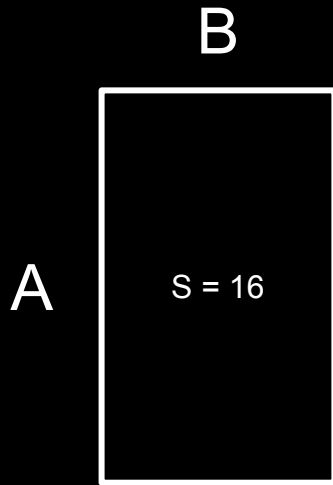
$$A = (A + B) / 2 = 17 / 2 = 8.5$$

$$B = X / A = 16 / 8.5 \approx 1.88$$



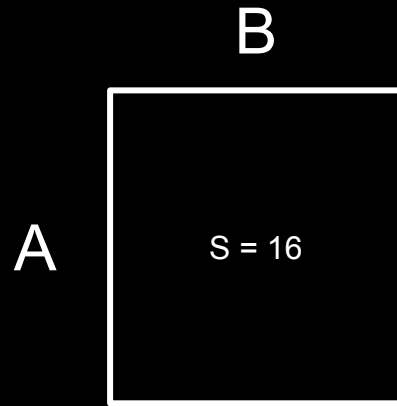
$$A = (A + B) / 2 \approx 10.38 / 2 \approx 5.19$$

$$B = X / A \approx 16 / 5.19 \approx 3.08$$



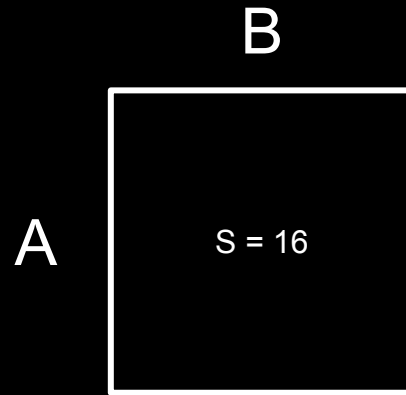
$$A = (A + B) / 2 \approx 8.27 / 2 \approx 4.14$$

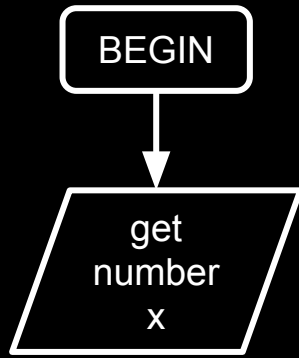
$$B = X / A \approx 16 / 4.14 \approx 3.86$$

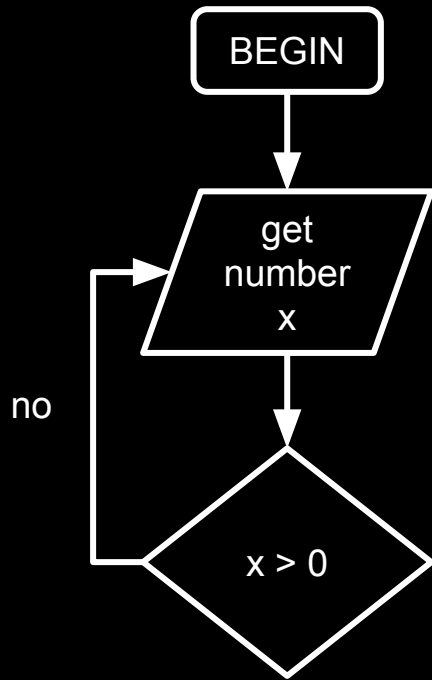


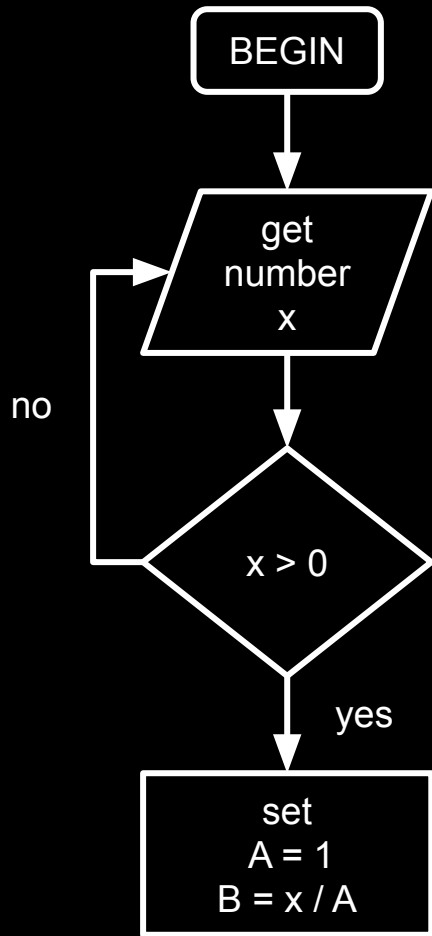
$$A = (A + B) / 2 = 8 / 2 = 4$$

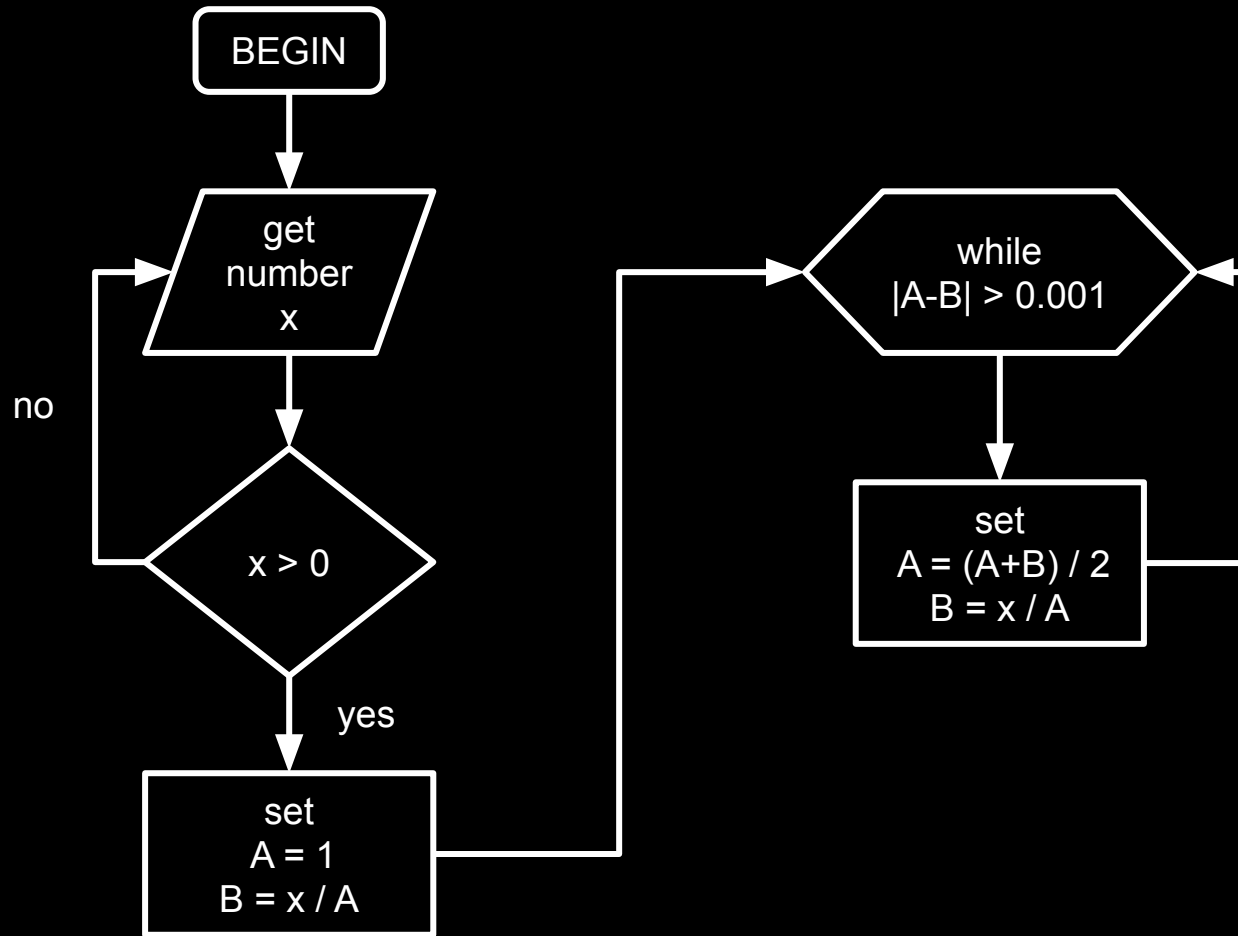
$$B = X / A = 16 / 4 = 4$$

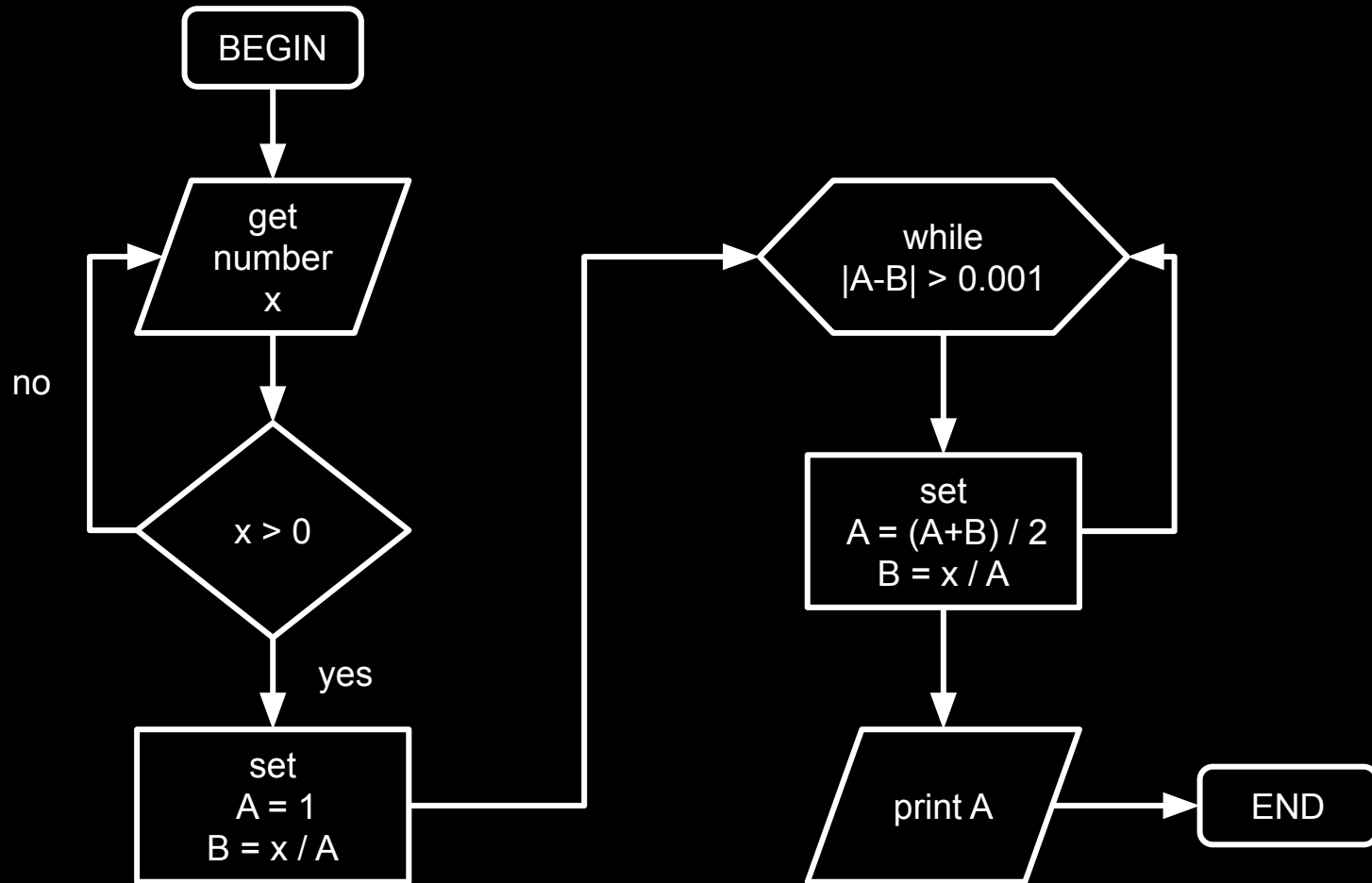






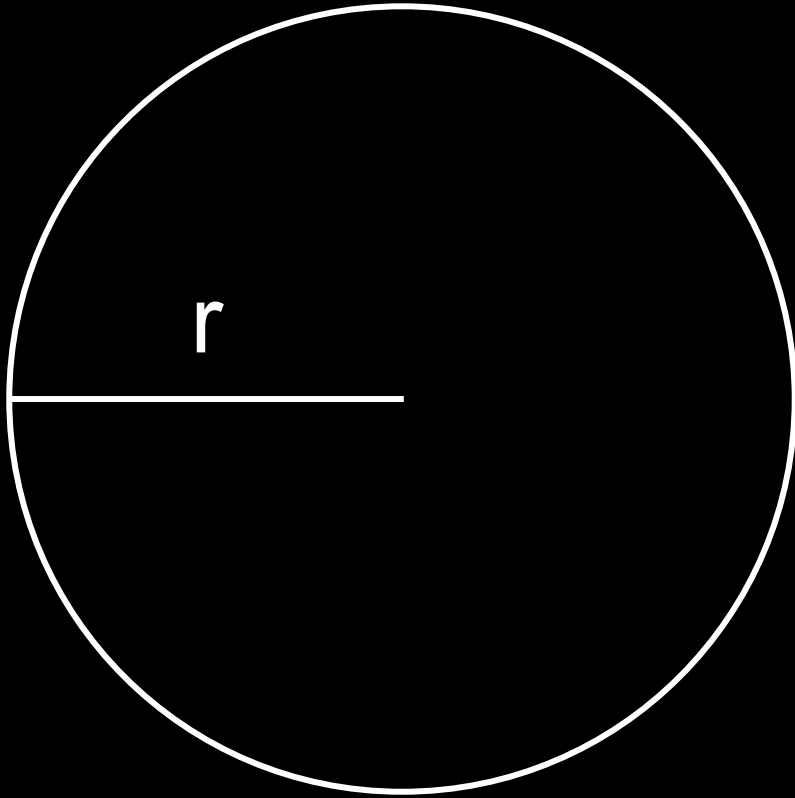


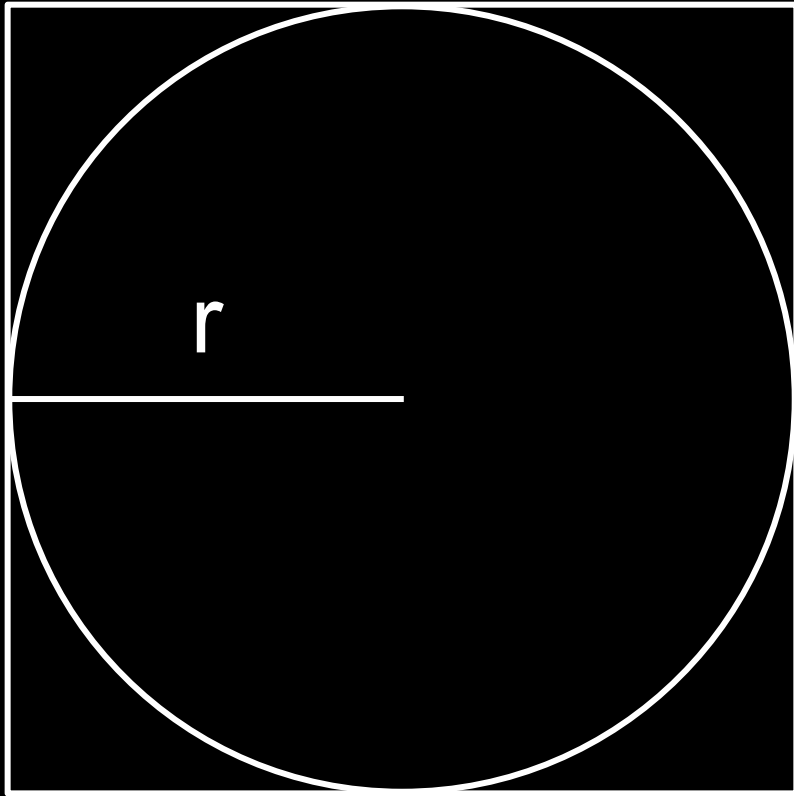


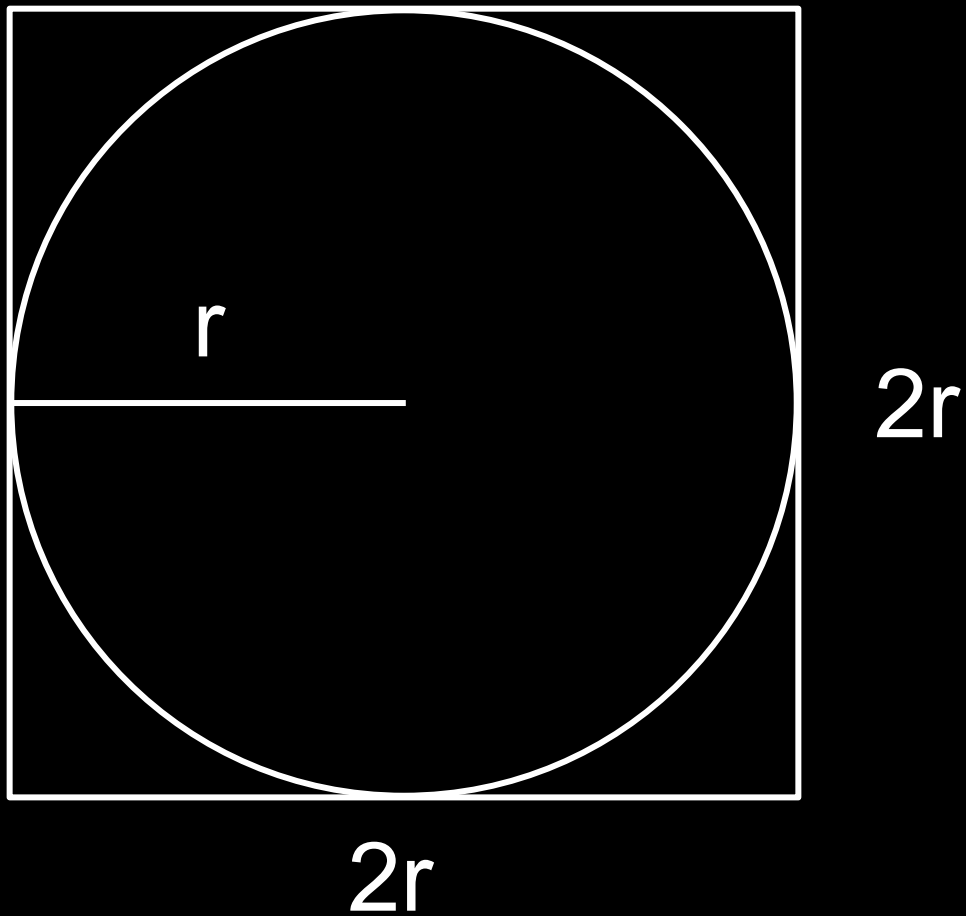


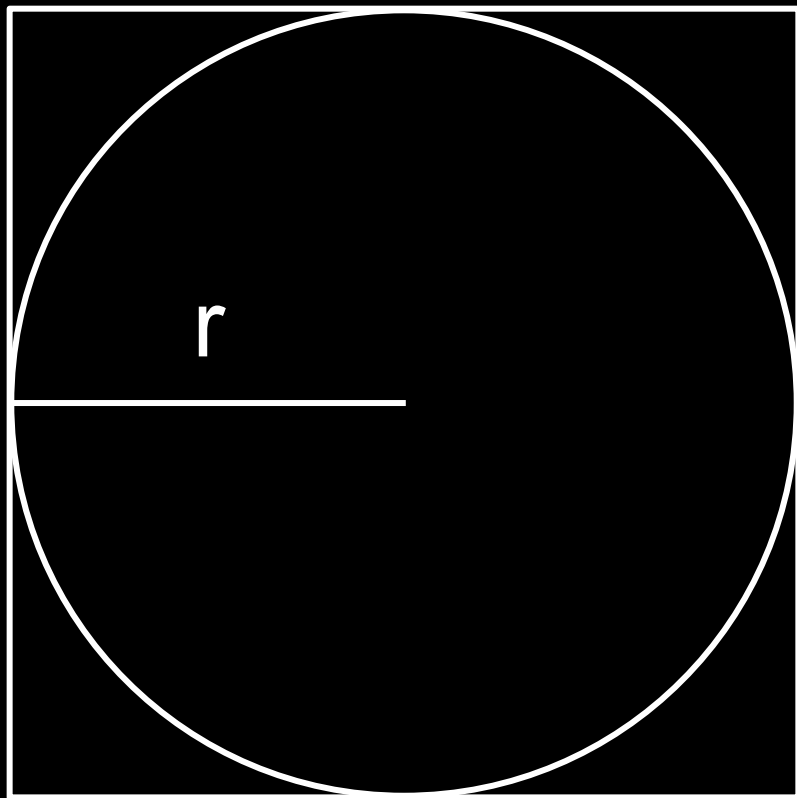


estimating π





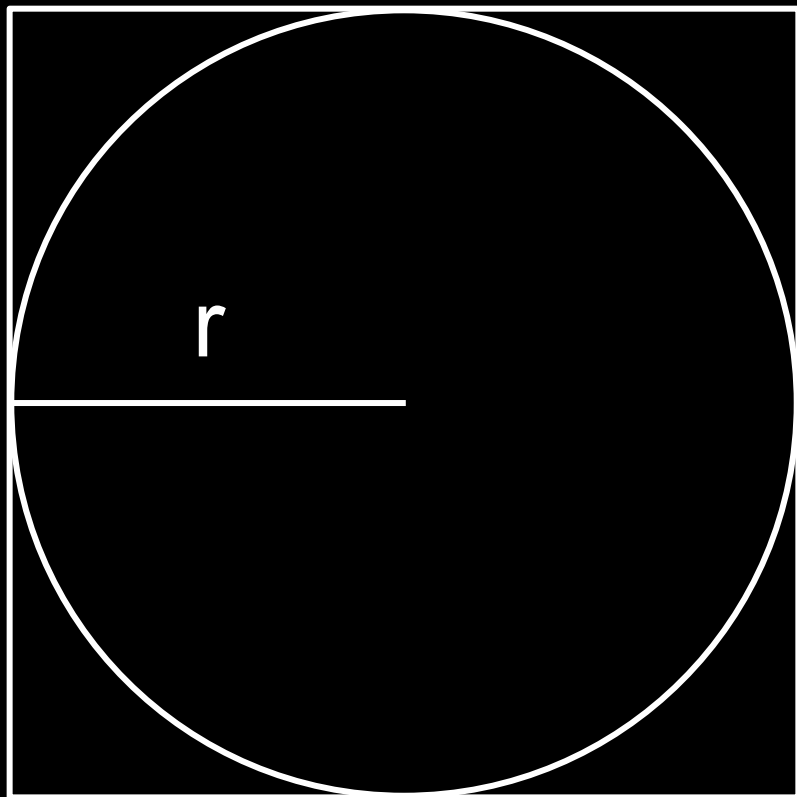




$2r$

$$\frac{\text{○}}{\text{□}} = \frac{\pi r^2}{4r^2}$$

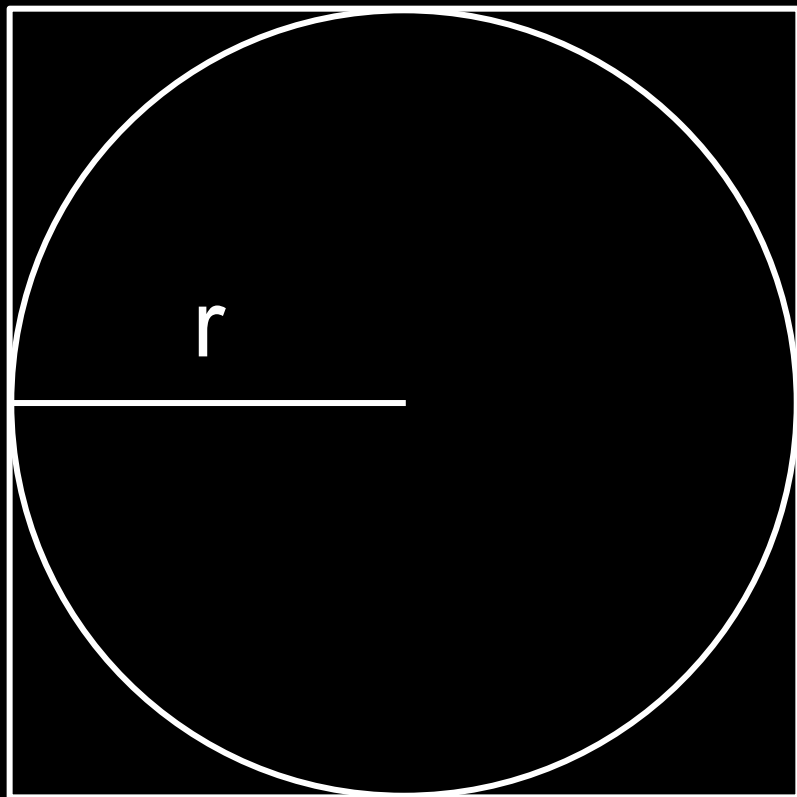
$2r$



$2r$

$$\frac{\text{○}}{\text{□}} = \frac{\pi r^2}{4r^2}$$

$2r$

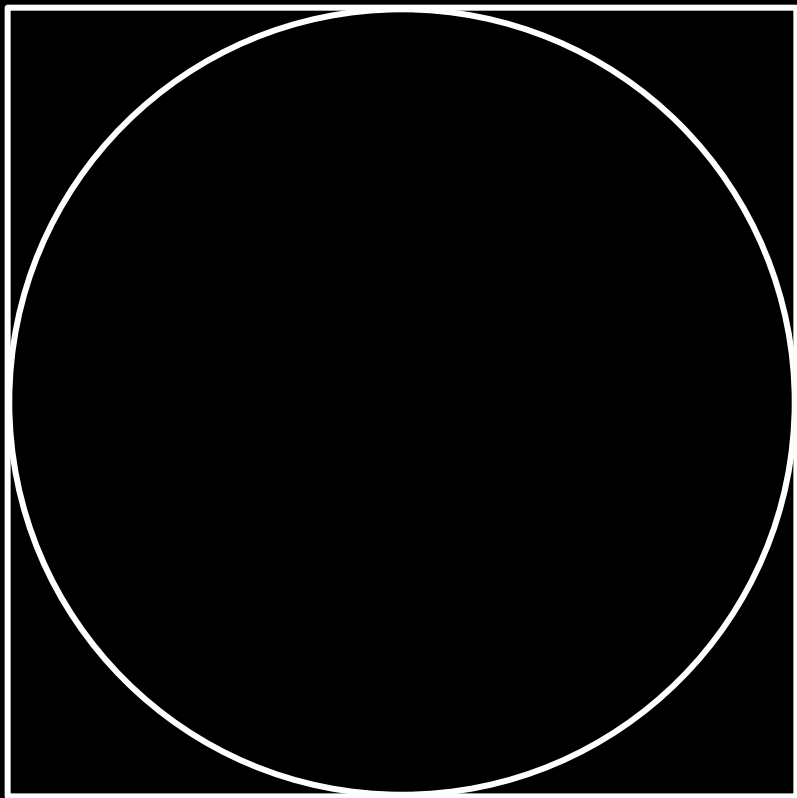


$2r$

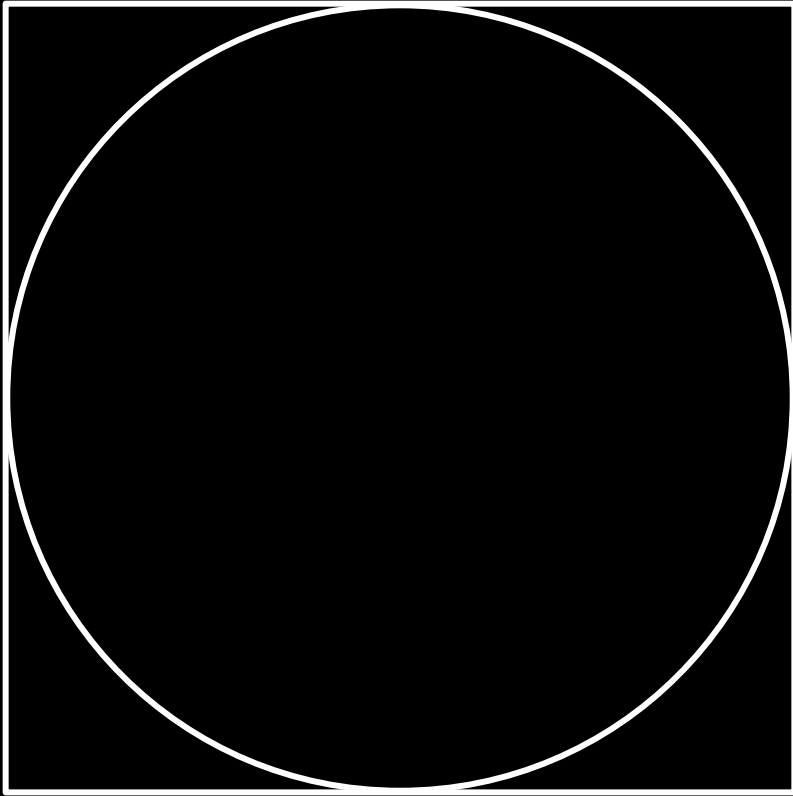
$$\frac{\text{○}}{\text{□}} = \frac{\pi}{4}$$

$2r$

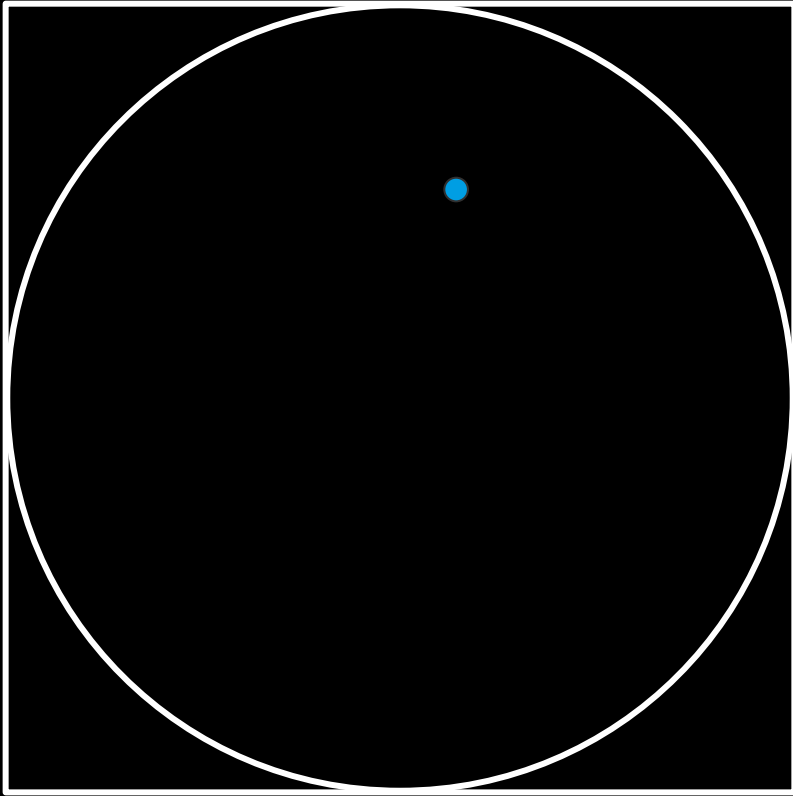
monte carlo simulation



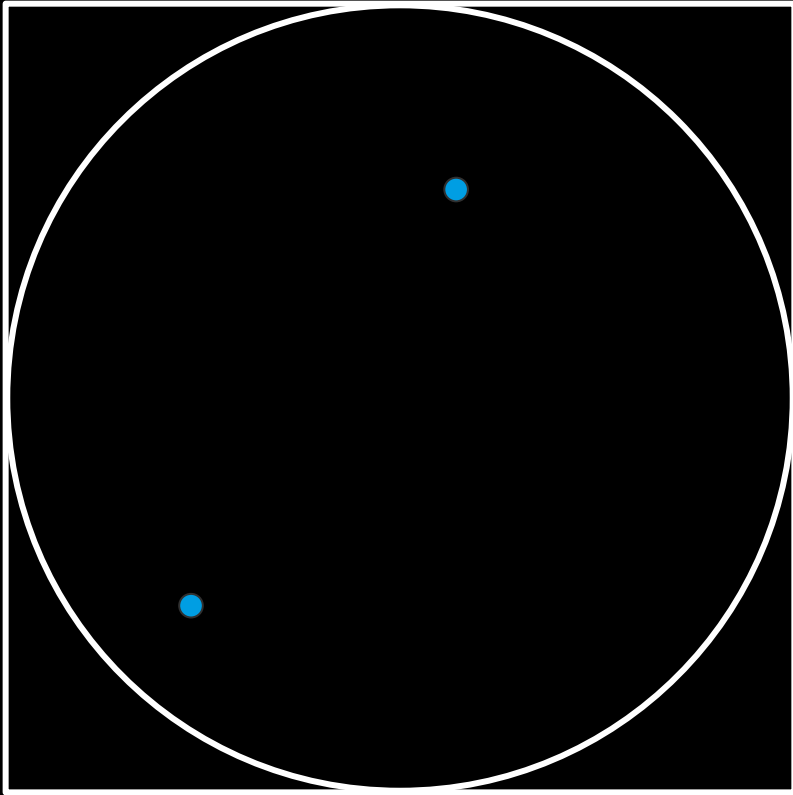
$$\frac{\text{Circle}}{\text{Square}} = \frac{\pi}{4}$$



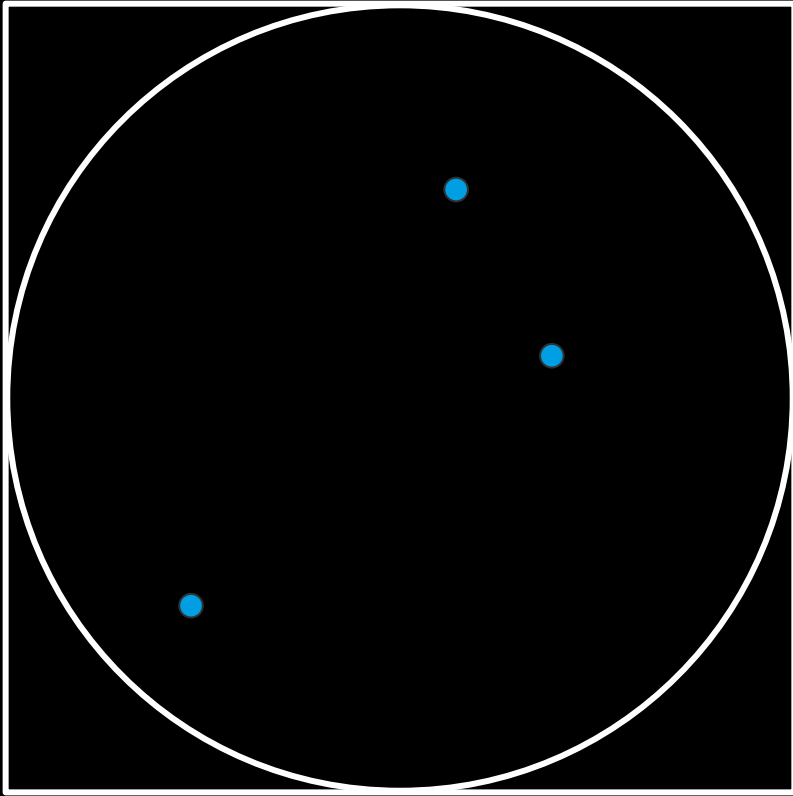
$$4 \frac{\text{O}}{\text{□}} = \pi$$



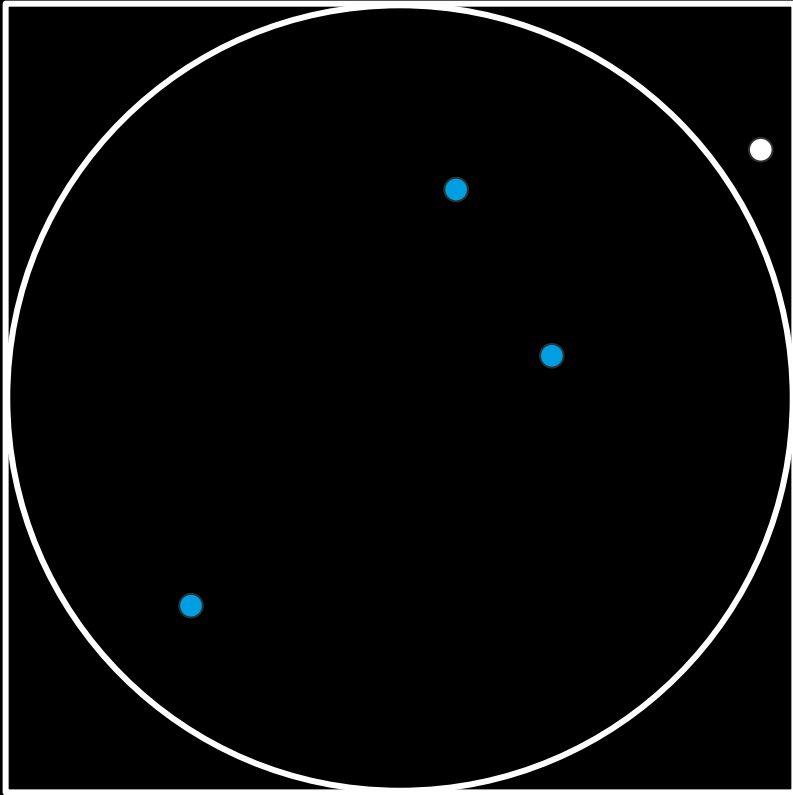
$$4 \frac{\text{O}}{\text{□}} = \pi$$
$$= 4$$



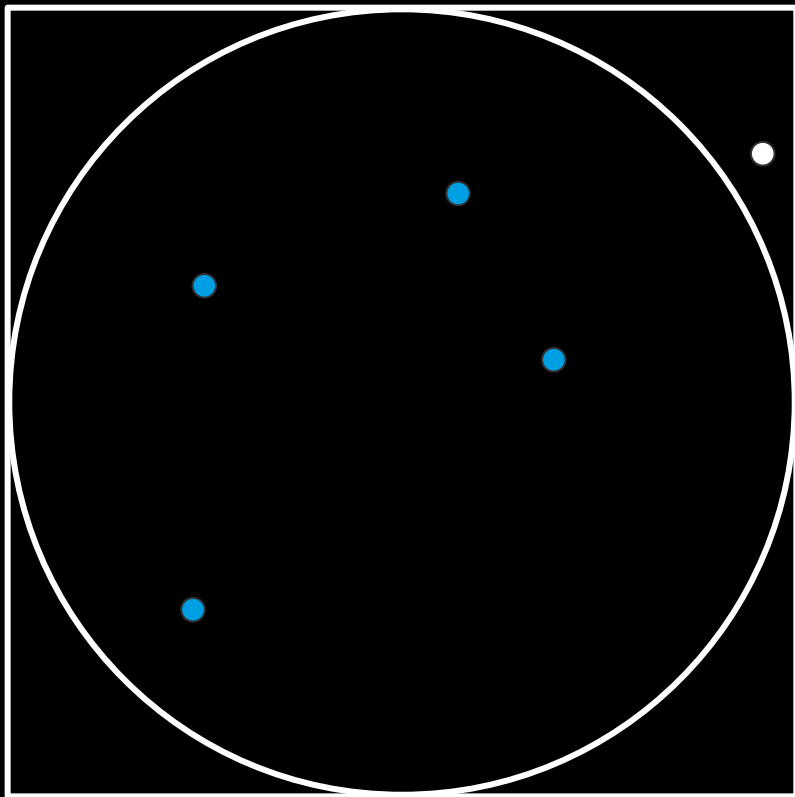
$$4 \frac{\text{O}}{\text{□}} = \pi$$
$$= 4$$



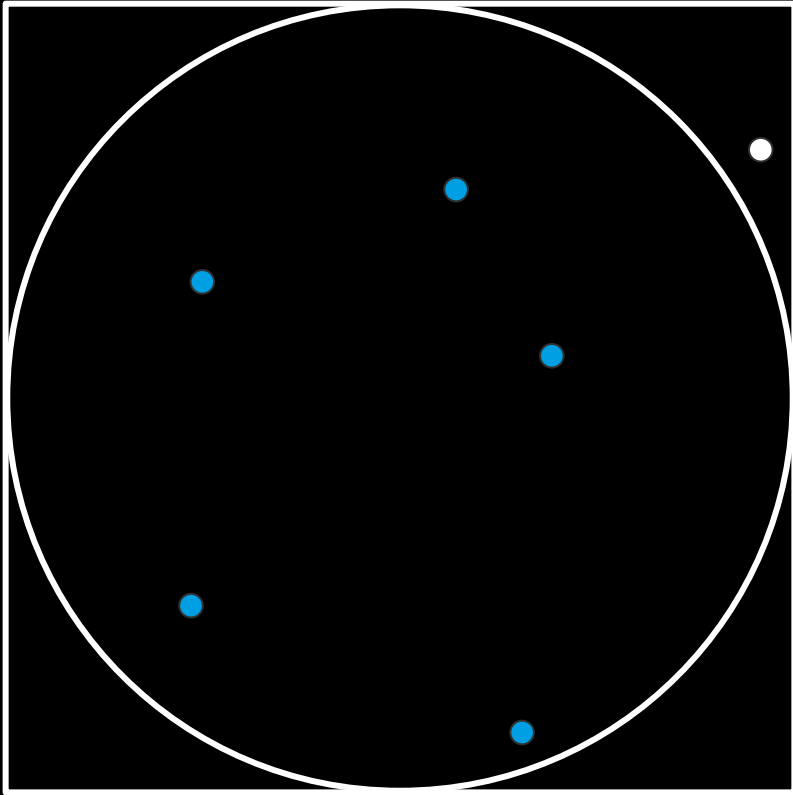
$$4 \frac{\text{Circle}}{\text{Square}} = \pi$$
$$= 4$$



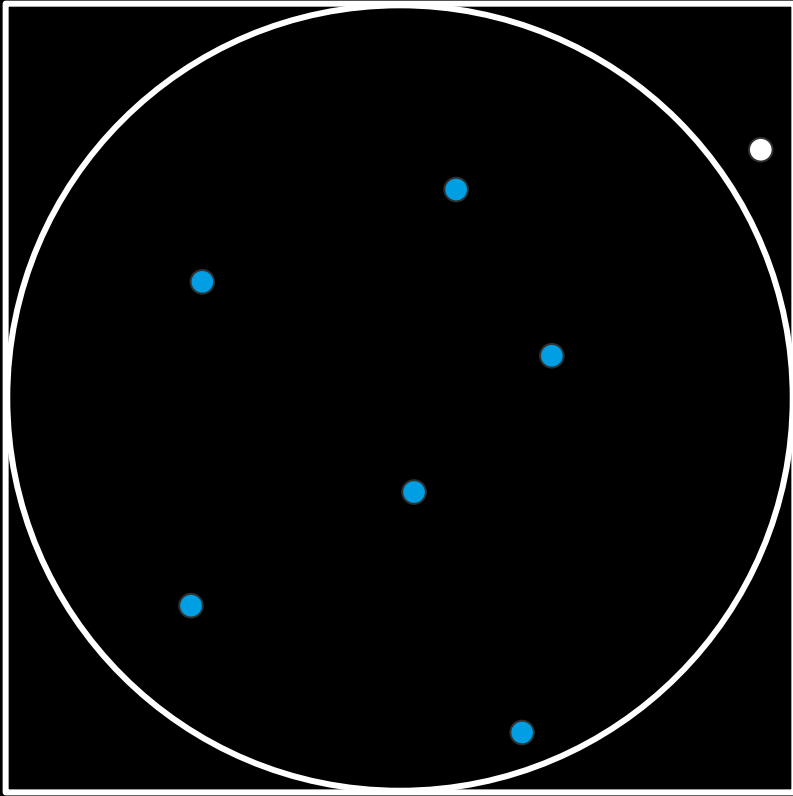
$$4 \frac{\text{circle}}{\text{square}} = \pi$$
$$= 3$$



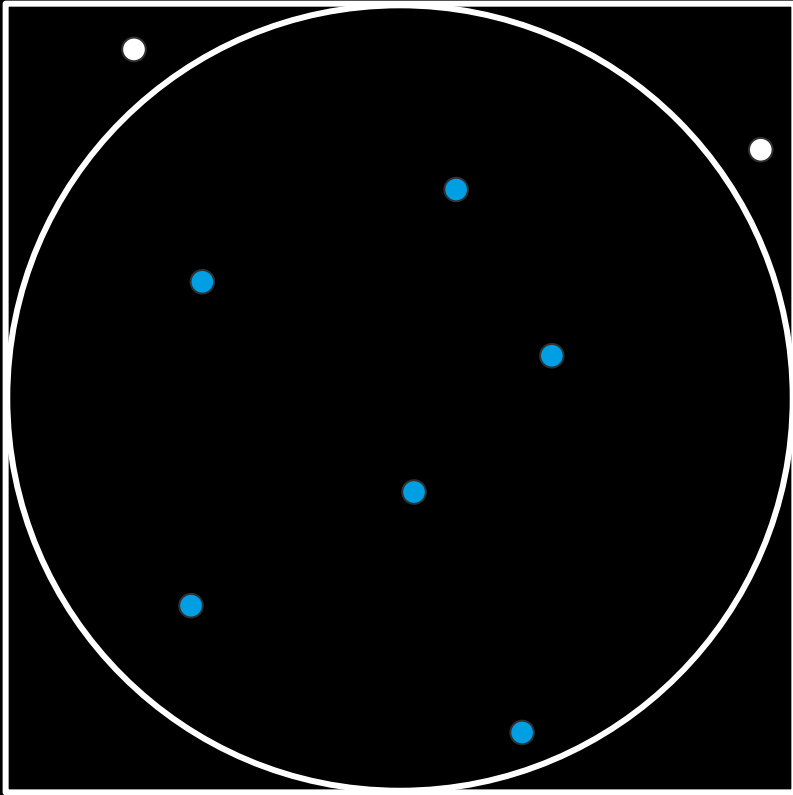
$$4 \frac{\text{O}}{\text{□}} = \pi$$
$$= 3,2$$



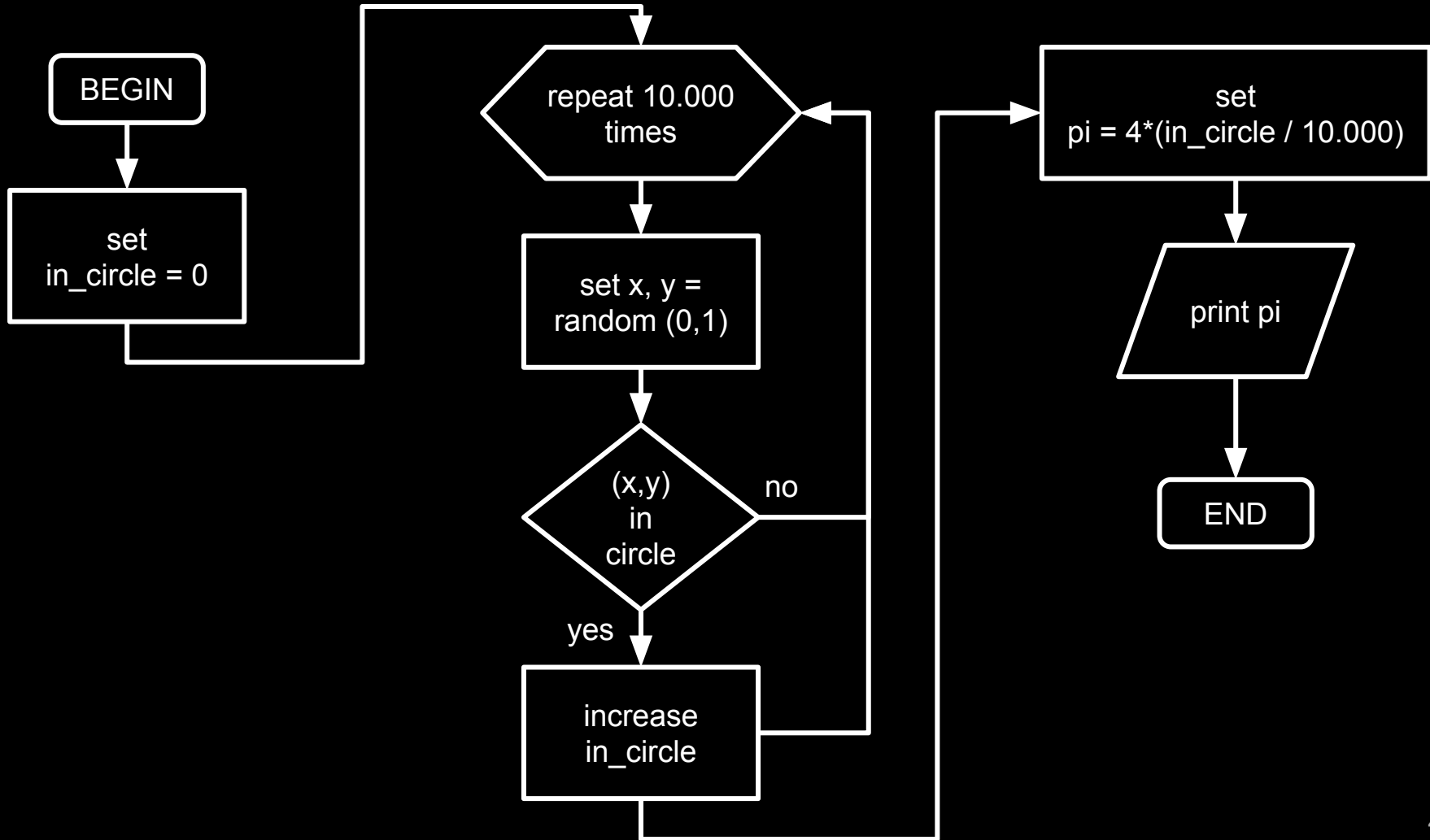
$$4 \frac{\text{Circle}}{\text{Square}} = \pi$$
$$= 3,33$$



$$4 \frac{\text{○}}{\text{□}} = \pi$$
$$= 3,43$$



$$4 \frac{\text{Area of Circle}}{\text{Area of Square}} = \pi$$
$$= 3$$



gregory-leibniz series

$$\pi = 4 \sum_{n=0}^{\infty} \frac{(-1)^n}{2n+1}$$

$$\pi = 4\left(1 - \frac{1}{3} + \frac{1}{5} - \frac{1}{7} + \frac{1}{9} - \frac{1}{11} + \dots\right)$$



sorting

[9, 5, 2, 1, 4, 7]

bubble sort

repeatedly compare and swap elements
until done.

[9, 5, 2, 1, 4, 7]

[9, 5, 2, 1, 4, 7] \longrightarrow 9 > 5 ?

[9, 5, 2, 1, 4, 7] \longrightarrow 9 > 5 ? $\xrightarrow{\text{yes}}$ [5, 9, 2, 1, 4, 7]

[9, 5, 2, 1, 4, 7] \longrightarrow 9 > 5 ? $\xrightarrow{\text{yes}}$ [5, 9, 2, 1, 4, 7]

[5, 9, 2, 1, 4, 7] \longrightarrow 9 > 2 ? $\xrightarrow{\text{yes}}$ [5, 2, 9, 1, 4, 7]

[9, 5, 2, 1, 4, 7] \longrightarrow 9 > 5 ? $\xrightarrow{\text{yes}}$ [5, 9, 2, 1, 4, 7]

[5, 9, 2, 1, 4, 7] \longrightarrow 9 > 2 ? $\xrightarrow{\text{yes}}$ [5, 2, 9, 1, 4, 7]

[5, 2, 9, 1, 4, 7] \longrightarrow 9 > 1 ? $\xrightarrow{\text{yes}}$ [5, 2, 1, 9, 4, 7]

[9, 5, 2, 1, 4, 7] \longrightarrow 9 > 5 ? $\xrightarrow{\text{yes}}$ [5, 9, 2, 1, 4, 7]

[5, 9, 2, 1, 4, 7] \longrightarrow 9 > 2 ? $\xrightarrow{\text{yes}}$ [5, 2, 9, 1, 4, 7]

[5, 2, 9, 1, 4, 7] \longrightarrow 9 > 1 ? $\xrightarrow{\text{yes}}$ [5, 2, 1, 9, 4, 7]

[5, 2, 1, 9, 4, 7] \longrightarrow 9 > 4 ? $\xrightarrow{\text{yes}}$ [5, 2, 1, 4, 9, 7]

[9, 5, 2, 1, 4, 7] \longrightarrow 9 > 5 ? $\xrightarrow{\text{yes}}$ [5, 9, 2, 1, 4, 7]

[5, 9, 2, 1, 4, 7] \longrightarrow 9 > 2 ? $\xrightarrow{\text{yes}}$ [5, 2, 9, 1, 4, 7]

[5, 2, 9, 1, 4, 7] \longrightarrow 9 > 1 ? $\xrightarrow{\text{yes}}$ [5, 2, 1, 9, 4, 7]

[5, 2, 1, 9, 4, 7] \longrightarrow 9 > 4 ? $\xrightarrow{\text{yes}}$ [5, 2, 1, 4, 9, 7]

[5, 2, 1, 4, 9, 7] \longrightarrow 9 > 7 ? $\xrightarrow{\text{yes}}$ [5, 2, 1, 4, 7, 9]

[5, 2, 1, 4, 7, 9] \longrightarrow 5 > 2 ? $\xrightarrow{\text{yes}}$ [2, 5, 1, 4, 7, 9]

[5, 2, 1, 4, 7, 9] \longrightarrow 5 > 2 ? $\xrightarrow{\text{yes}}$ [2, 5, 1, 4, 7, 9]

[2, 5, 1, 4, 7, 9] \longrightarrow 5 > 1 ? $\xrightarrow{\text{yes}}$ [2, 1, 5, 4, 7, 9]

[5, 2, 1, 4, 7, 9] \longrightarrow 5 > 2 ? $\xrightarrow{\text{yes}}$ [2, 5, 1, 4, 7, 9]

[2, 5, 1, 4, 7, 9] \longrightarrow 5 > 1 ? $\xrightarrow{\text{yes}}$ [2, 1, 5, 4, 7, 9]

[2, 1, 5, 4, 7, 9] \longrightarrow 5 > 4 ? $\xrightarrow{\text{yes}}$ [2, 1, 4, 5, 7, 9]

[5, 2, 1, 4, 7, 9] \longrightarrow 5 > 2 ? $\xrightarrow{\text{yes}}$ [2, 5, 1, 4, 7, 9]

[2, 5, 1, 4, 7, 9] \longrightarrow 5 > 1 ? $\xrightarrow{\text{yes}}$ [2, 1, 5, 4, 7, 9]

[2, 1, 5, 4, 7, 9] \longrightarrow 5 > 4 ? $\xrightarrow{\text{yes}}$ [2, 1, 4, 5, 7, 9]

[2, 1, 4, 5, 7, 9] \longrightarrow 5 > 7 ? $\xrightarrow{\text{no}}$ [2, 1, 4, 5, 7, 9]

[2, 1, 4, 5, 7, 9] \longrightarrow 2 > 1? $\xrightarrow{\text{yes}}$ [1, 2, 4, 5, 7, 9]

[2, 1, 4, 5, 7, 9] \longrightarrow 2 > 1 ? $\xrightarrow{\text{yes}}$ [1, 2, 4, 5, 7, 9]

[1, 2, 4, 5, 7, 9] \longrightarrow 2 > 4 ? $\xrightarrow{\text{no}}$ [1, 2, 4, 5, 7, 9]

[2, 1, 4, 5, 7, 9] \longrightarrow 2 > 1 ? $\xrightarrow{\text{yes}}$ [1, 2, 4, 5, 7, 9]

[1, 2, 4, 5, 7, 9] \longrightarrow 2 > 4 ? $\xrightarrow{\text{no}}$ [1, 2, 4, 5, 7, 9]

[1, 2, 4, 5, 7, 9] \longrightarrow 4 > 5 ? $\xrightarrow{\text{no}}$ [1, 2, 4, 5, 7, 9]

[1, 2, 4, 5, 7, 9] \longrightarrow 1 > 2 ? $\xrightarrow{\text{no}}$ [1, 2, 4, 5, 7, 9]

[1, 2, 4, 5, 7, 9] \longrightarrow 1 > 2 ? $\xrightarrow{\text{no}}$ [1, 2, 4, 5, 7, 9]

[1, 2, 4, 5, 7, 9] \longrightarrow 2 > 4 ? $\xrightarrow{\text{no}}$ [1, 2, 4, 5, 7, 9]

[1, 2, 4, 5, 7, 9] \longrightarrow 1 > 2 ? $\xrightarrow{\text{no}}$ [1, 2, 4, 5, 7, 9]

[1, 2, 4, 5, 7, 9] \longrightarrow 1 > 2 ? $\xrightarrow{\text{no}}$ [1, 2, 4, 5, 7, 9]

[1, 2, 4, 5, 7, 9] DONE!

selection sort

find the smallest element and move it to front. repeat for the rest of the elements.

[9, 5, 2, 1, 4, 7] $\xrightarrow{\text{move to front}}$ [1, 5, 9, 2, 4, 7]

move to front

[9, 5, 2, 1, 4, 7] → [1, 5, 9, 2, 4, 7]

[1, 5, 9, 2, 4, 7] → [1, 2, 5, 9, 4, 7]

move to front

[9, 5, 2, 1, 4, 7] → [1, 5, 9, 2, 4, 7]

[1, 5, 9, 2, 4, 7] → [1, 2, 5, 9, 4, 7]

[1, 2, 5, 9, 4, 7] → [1, 2, 4, 5, 9, 7]

move to front

[9, 5, 2, 1, 4, 7] → [1, 5, 9, 2, 4, 7]

[1, 5, 9, 2, 4, 7] → [1, 2, 5, 9, 4, 7]

[1, 2, 5, 9, 4, 7] → [1, 2, 4, 5, 9, 7]

[1, 2, 4, 5, 9, 7] → [1, 2, 4, 5, 9, 7]

move to front

[9, 5, 2, 1, 4, 7] → [1, 5, 9, 2, 4, 7]

[1, 5, 9, 2, 4, 7] → [1, 2, 5, 9, 4, 7]

[1, 2, 5, 9, 4, 7] → [1, 2, 4, 5, 9, 7]

[1, 2, 4, 5, 9, 7] → [1, 2, 4, 5, 9, 7]

[1, 2, 4, 5, 9, 7] → [1, 2, 4, 5, 7, 9]

move to front

[9, 5, 2, 1, 4, 7] → [1, 5, 9, 2, 4, 7]

[1, 5, 9, 2, 4, 7] → [1, 2, 5, 9, 4, 7]

[1, 2, 5, 9, 4, 7] → [1, 2, 4, 5, 9, 7]

[1, 2, 4, 5, 9, 7] → [1, 2, 4, 5, 9, 7]

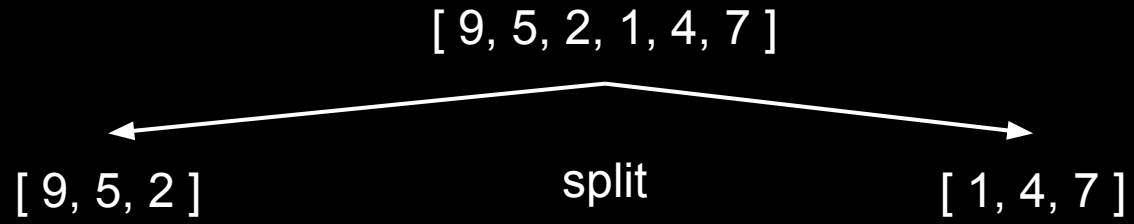
[1, 2, 4, 5, 9, 7] → [1, 2, 4, 5, 7, 9]

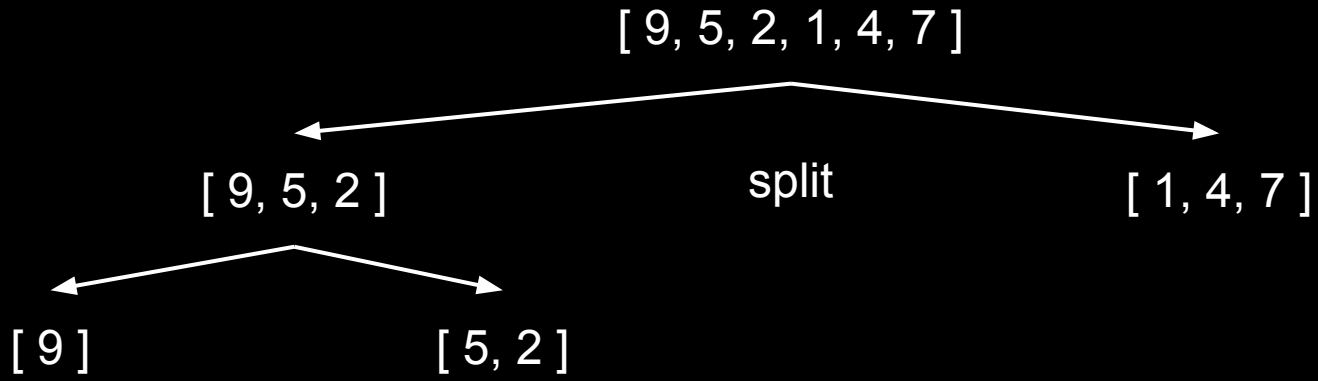
[1, 2, 4, 5, 7, 9] → [1, 2, 4, 5, 7, 9]

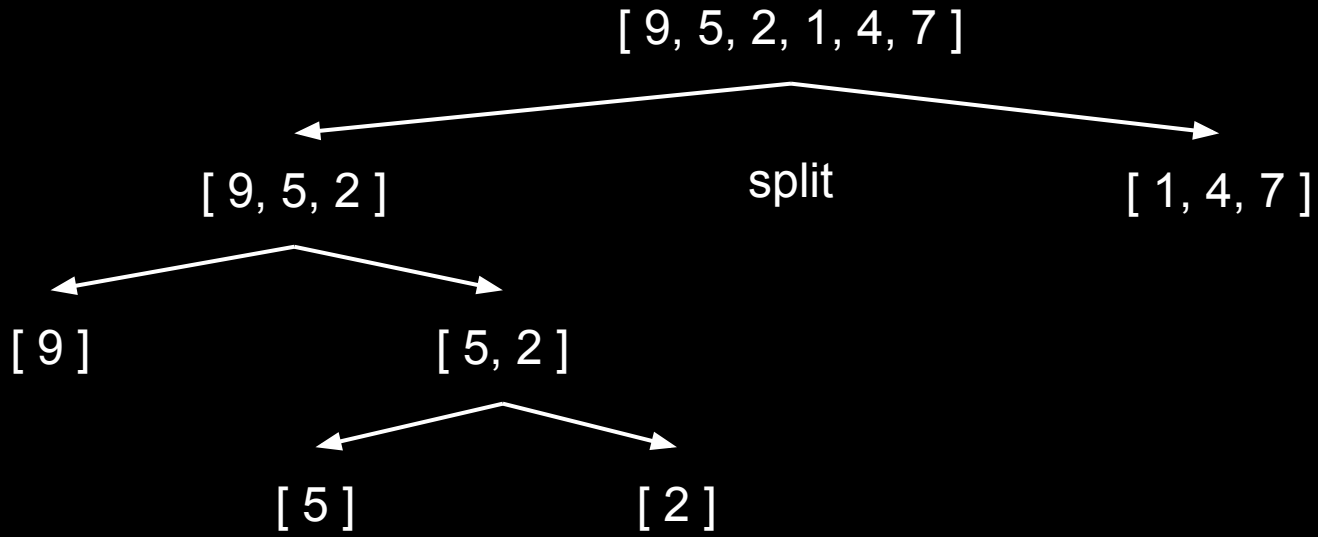
merge sort

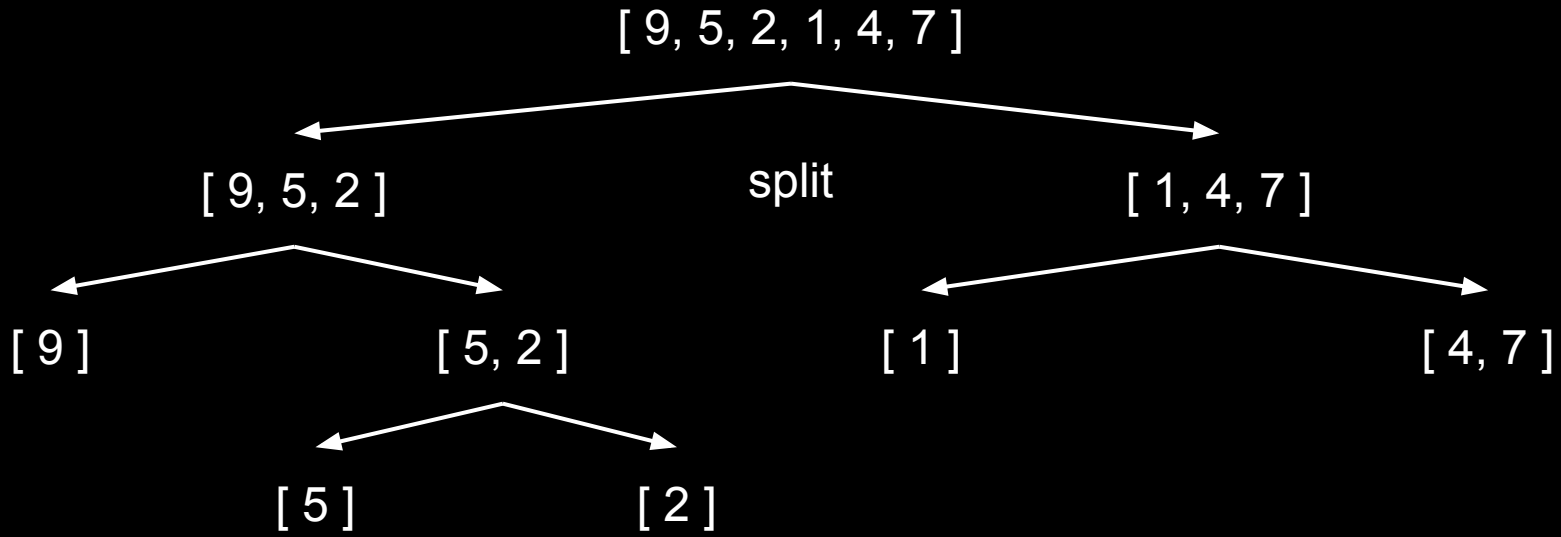
divide the elements recursively in two halves until only one element is left.
then merge the sorted halves back together.

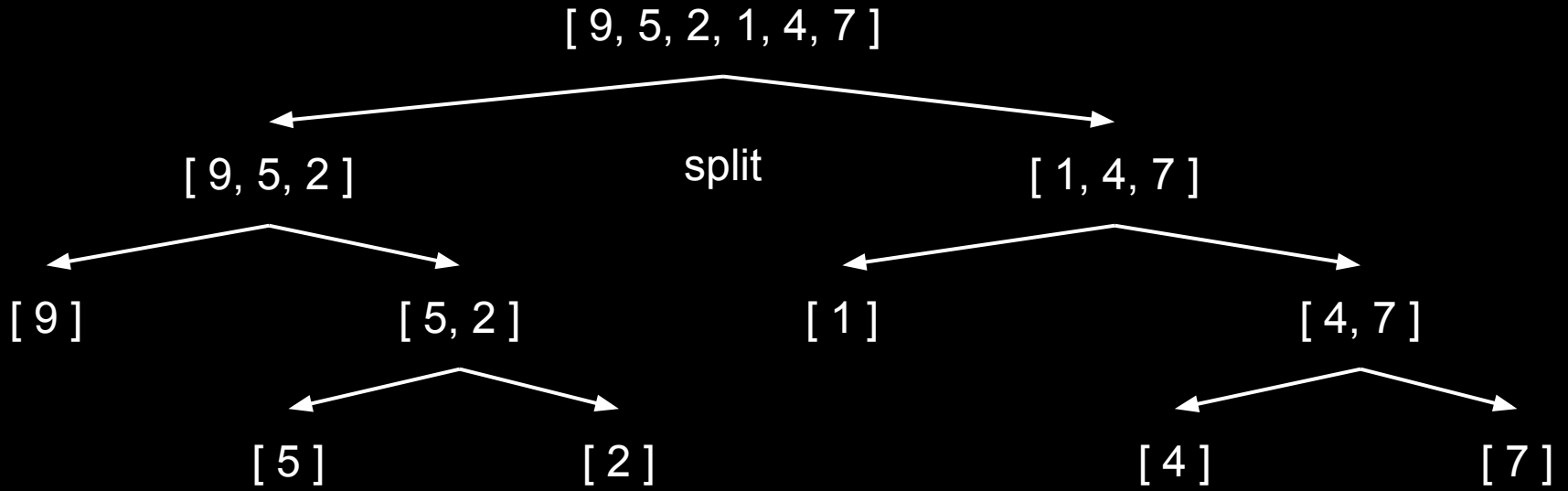
divide the elements **recursively** in two halves until only one element is left.
then merge the sorted halves back together.

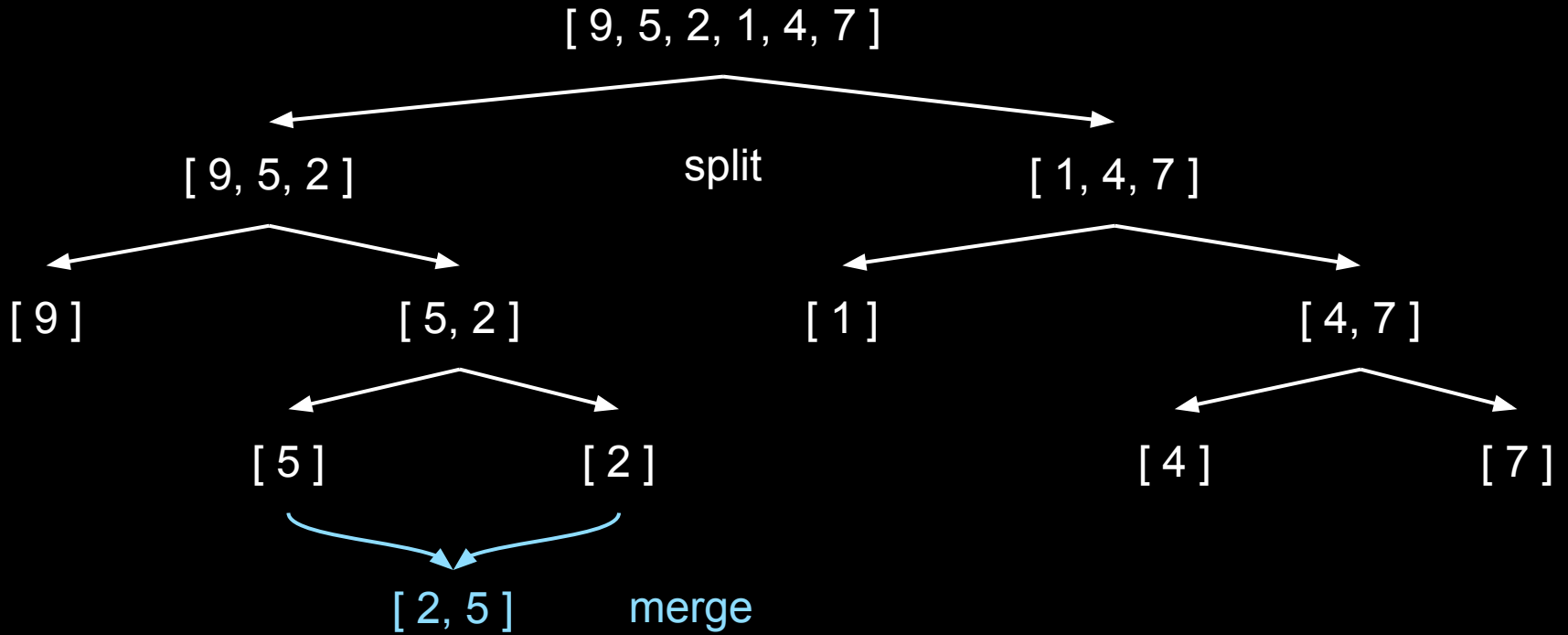


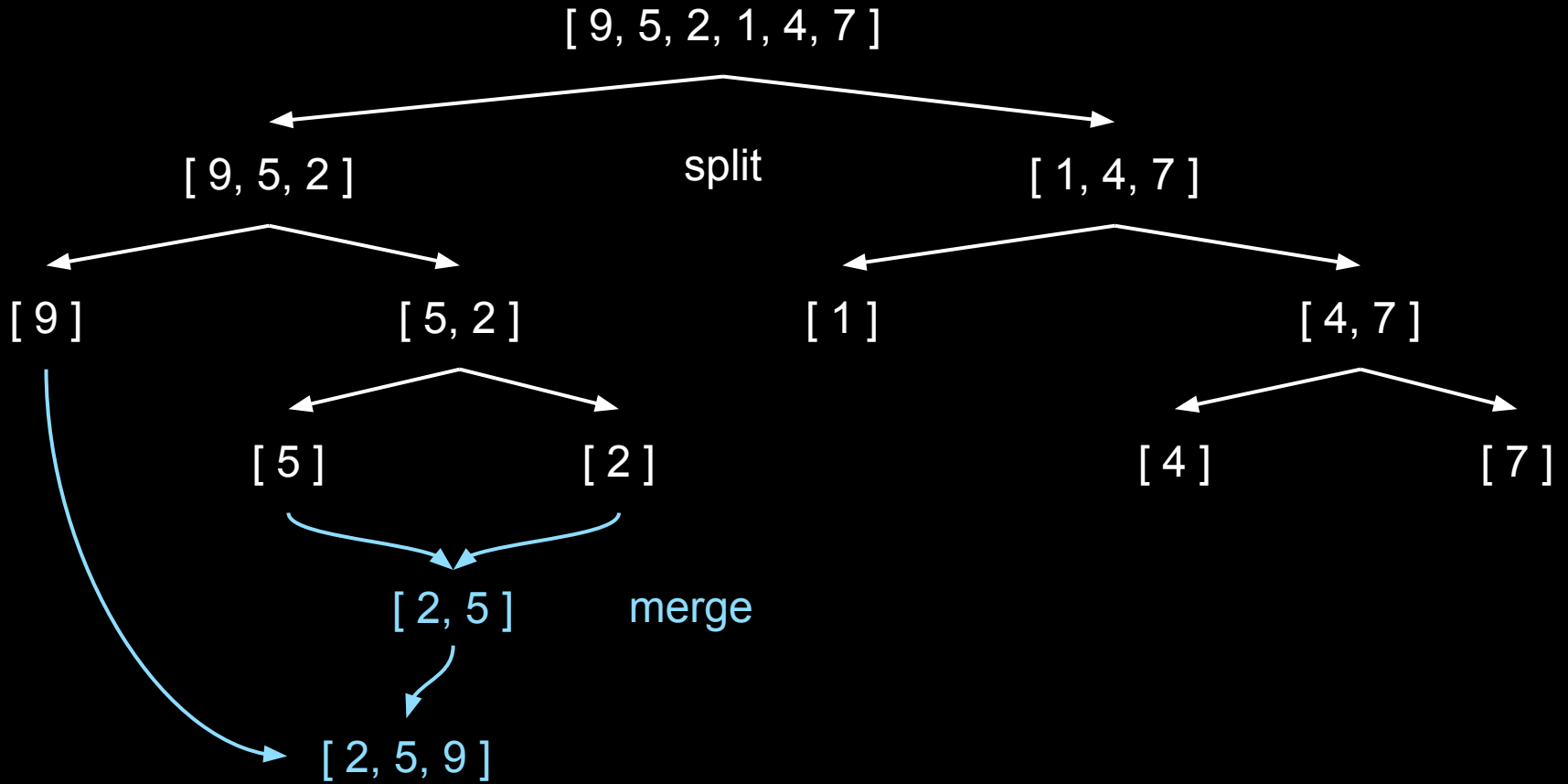


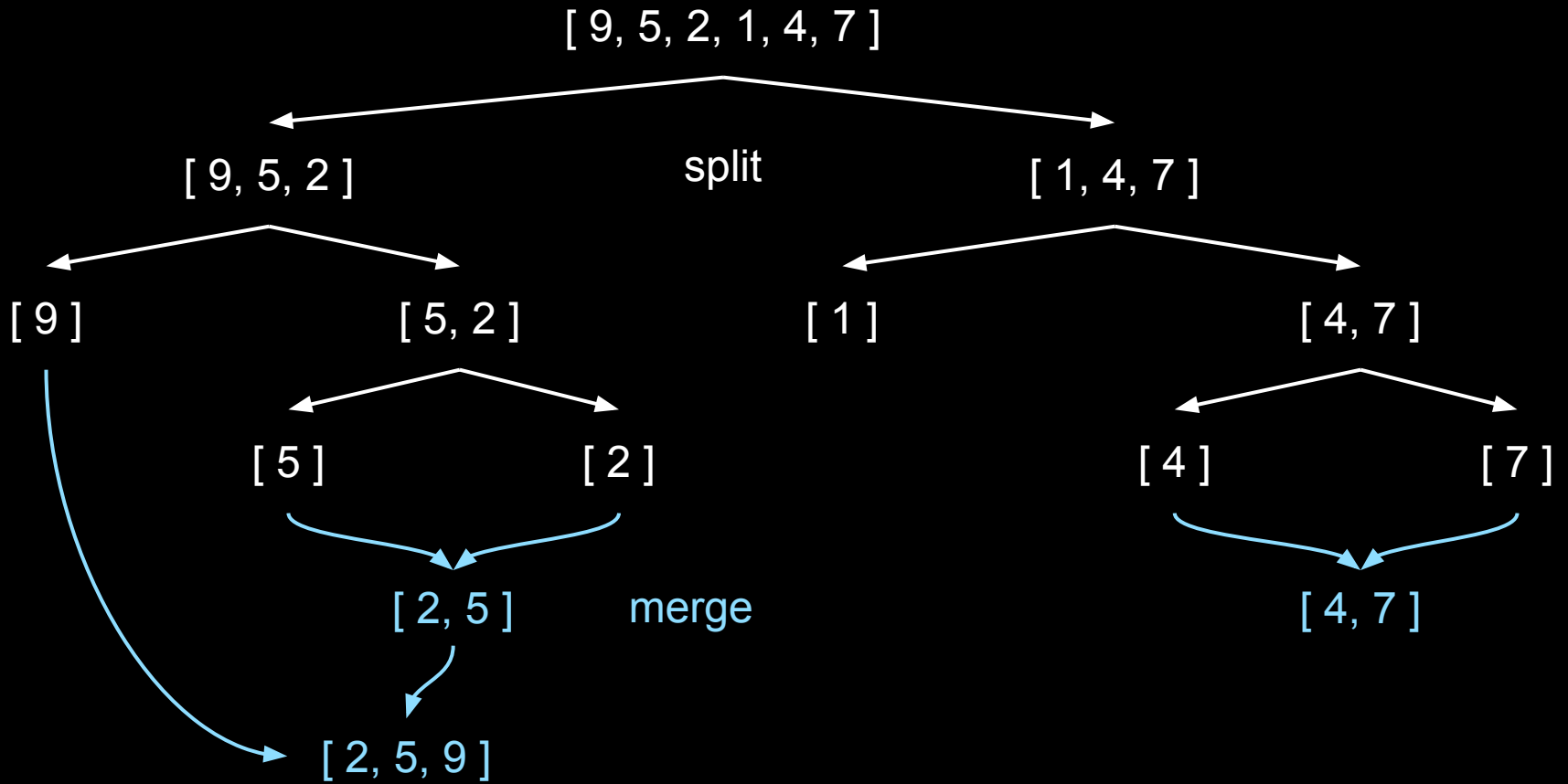


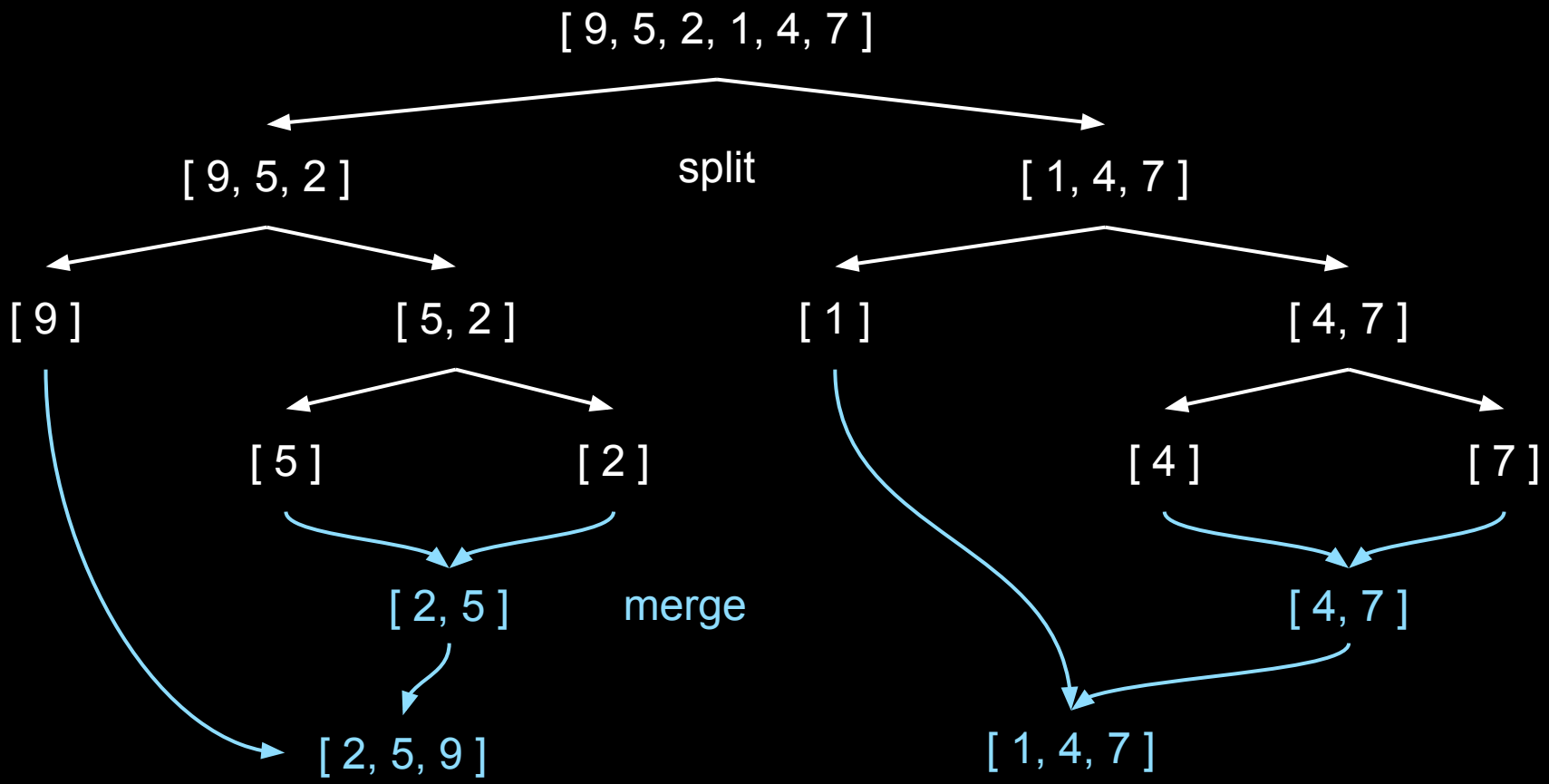


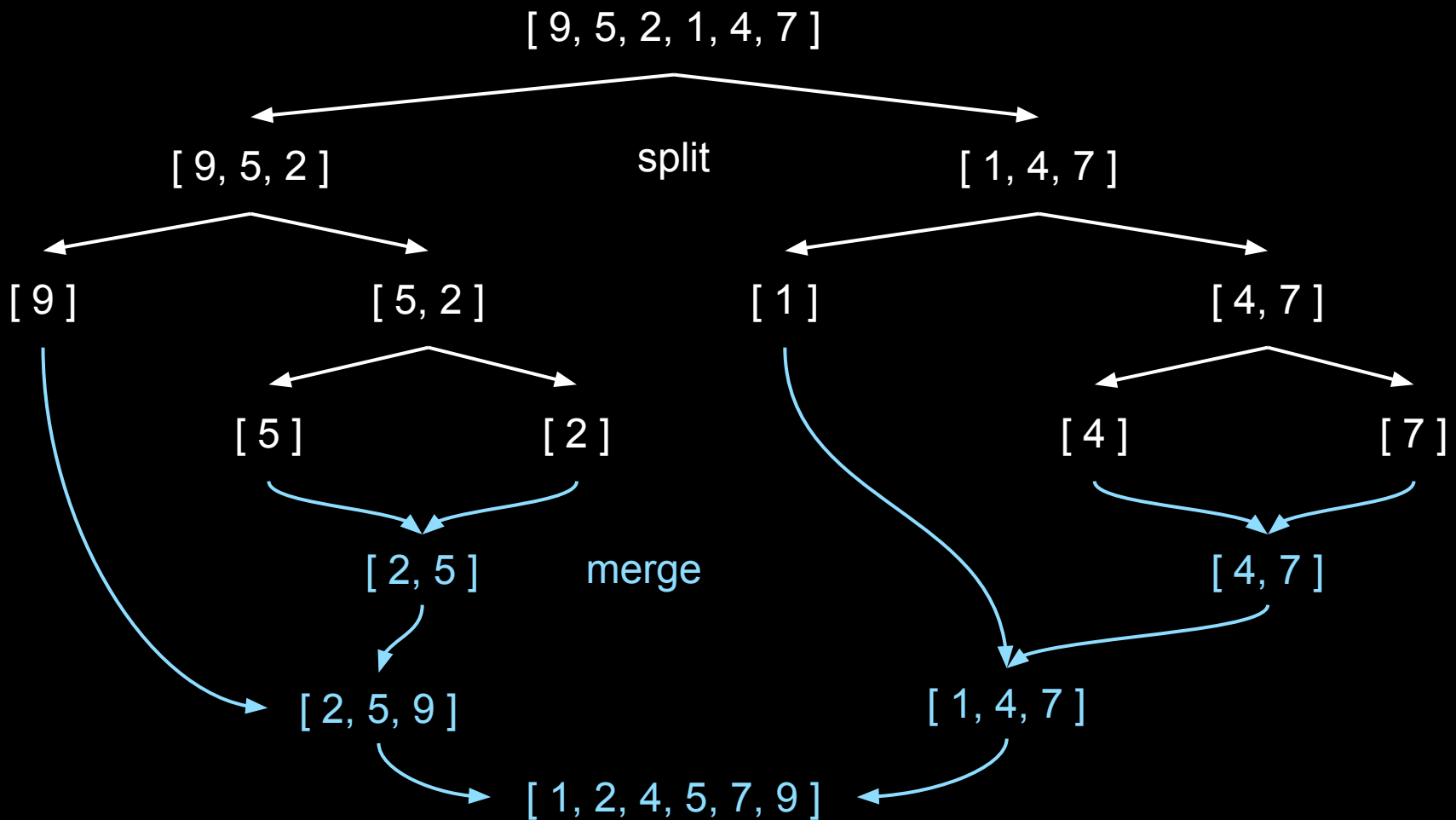




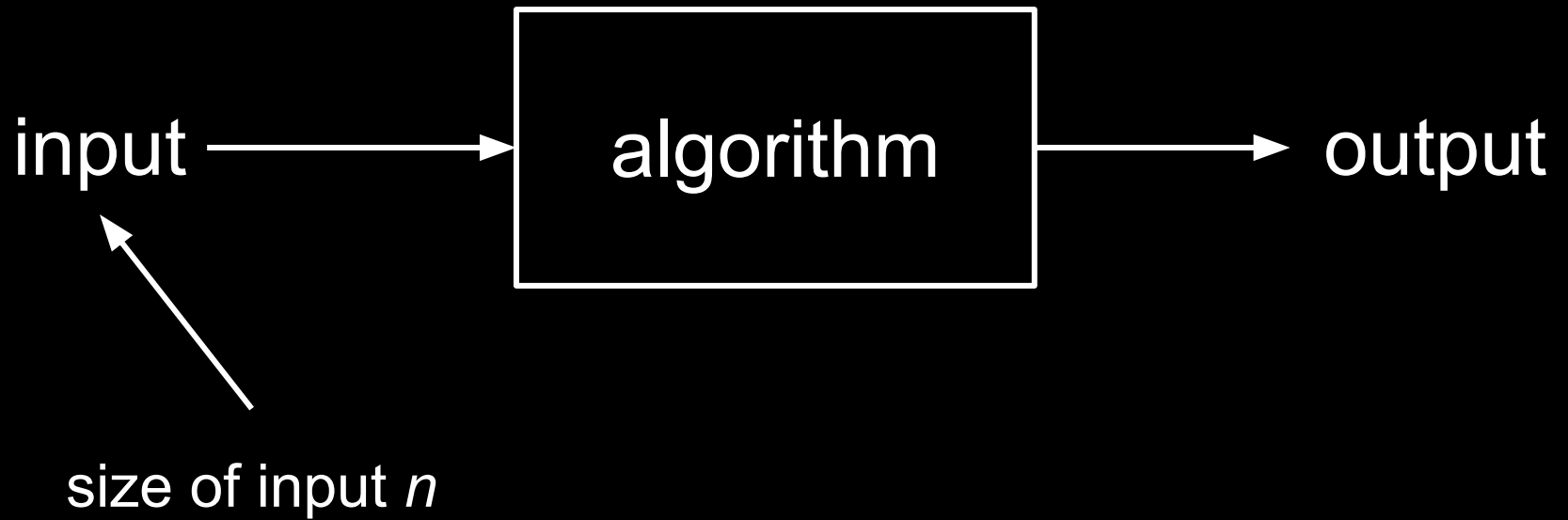


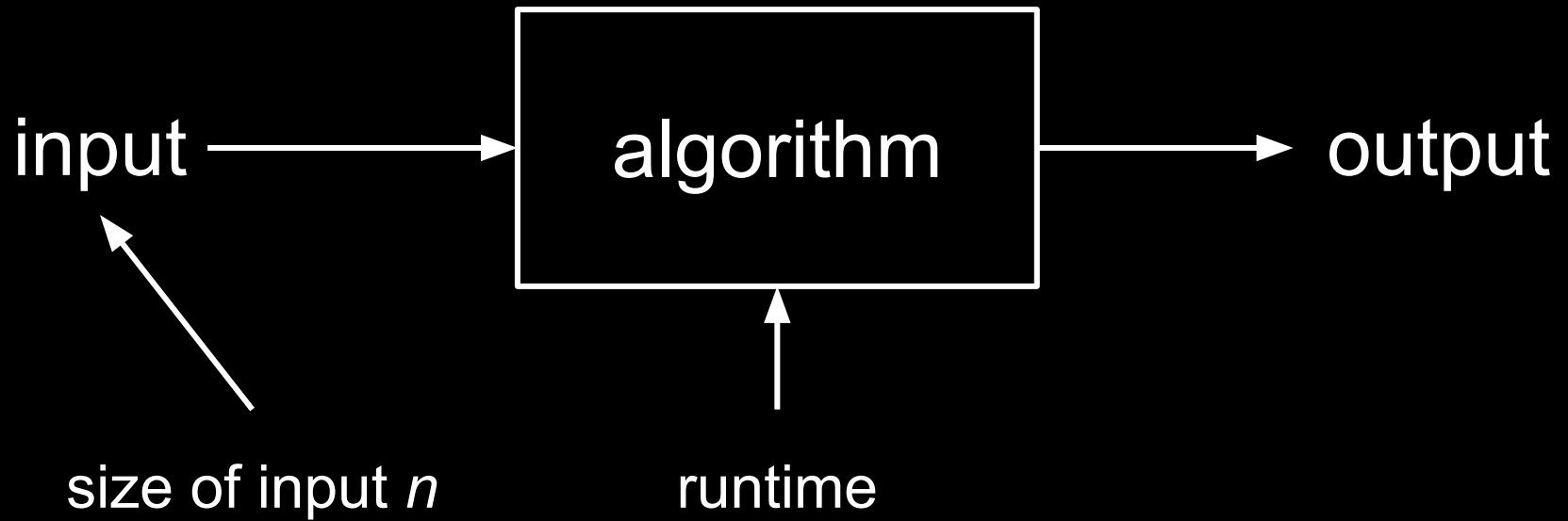




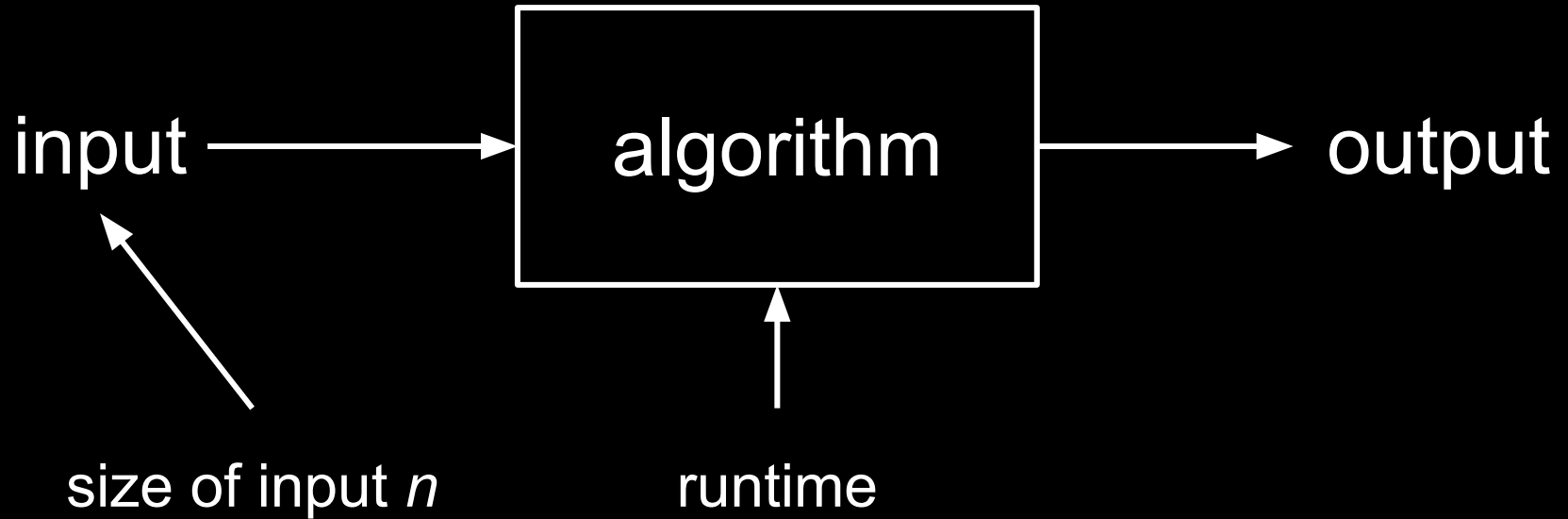


complexity





$O(n)$



$O(1)$	runtime is constant and independent of problem size
$O(\log_2 n)$	runtime is determined by the logarithm of problem size
$O(n)$	runtime is linear to problem size
$O(n^2)$	runtime grows quadratically with the size of the problem
$O(n^3)$	runtime grows cubically with the size of the problem
$O(2^n)$	runtime grows exponentially with the size of the problem
$O(n!)$	runtime grows factorially with the size of the problem

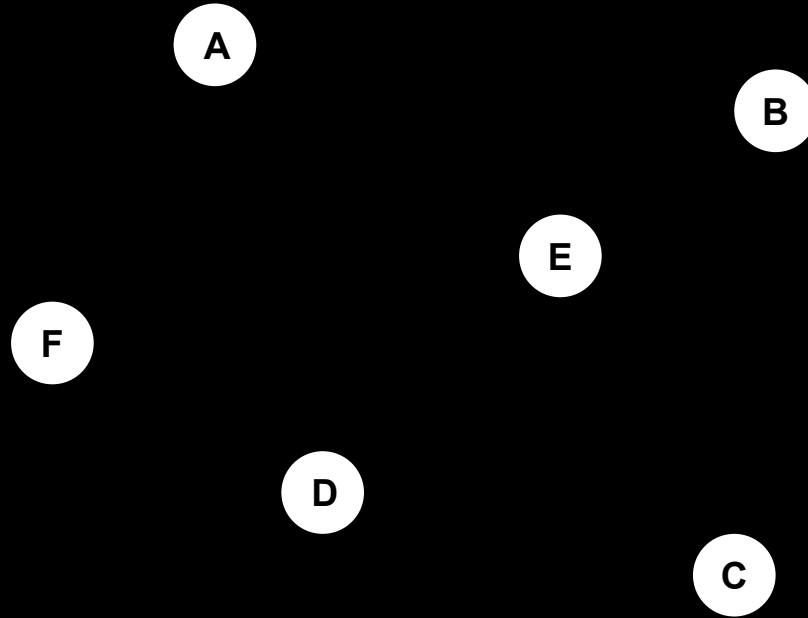


optimization

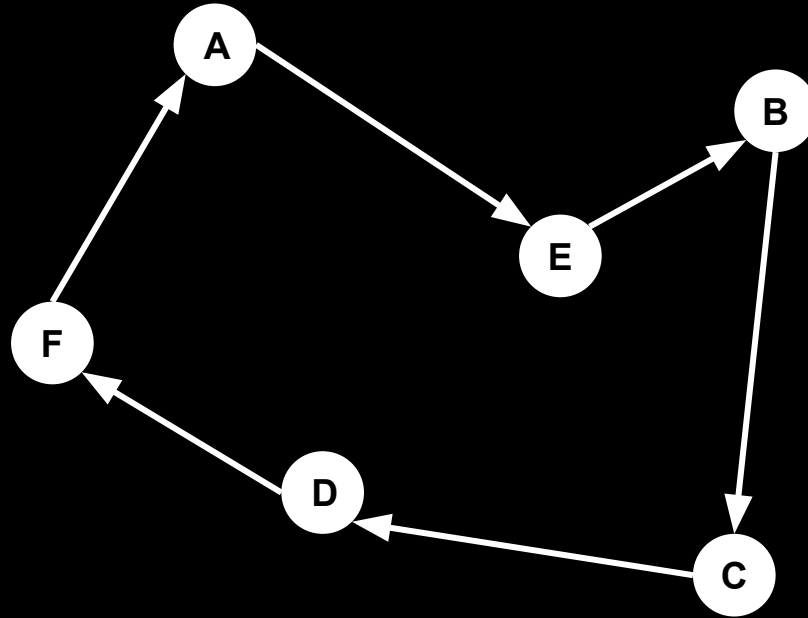


traveling salesmen

shortest tour?



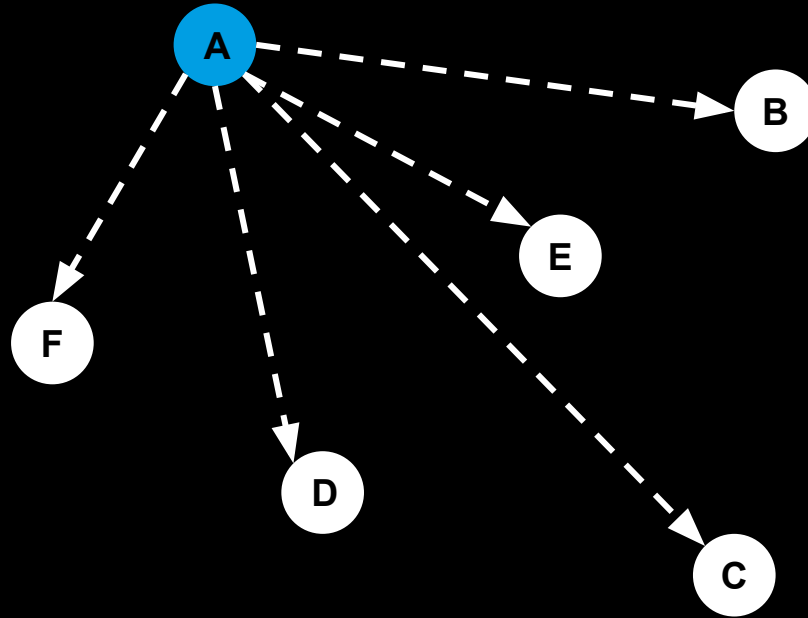
shortest tour?



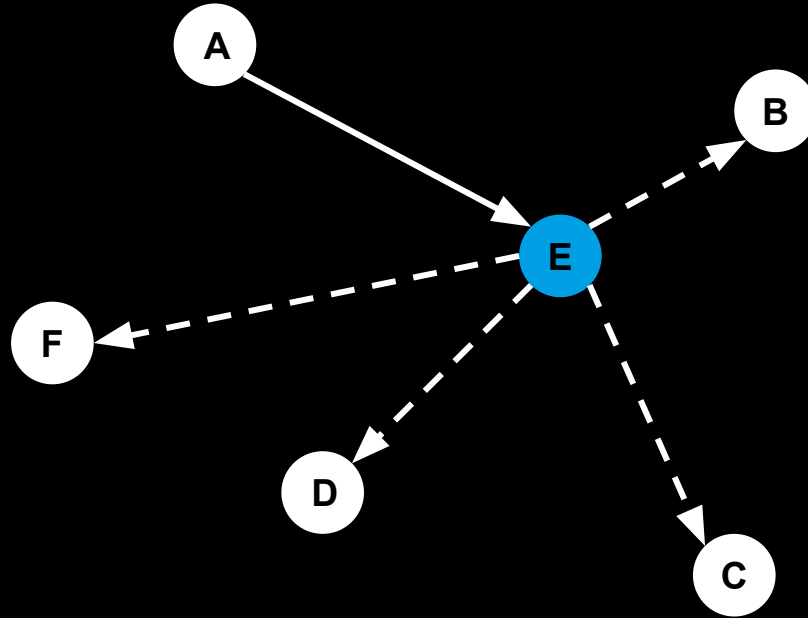
brute force

$$O(n) = n!$$

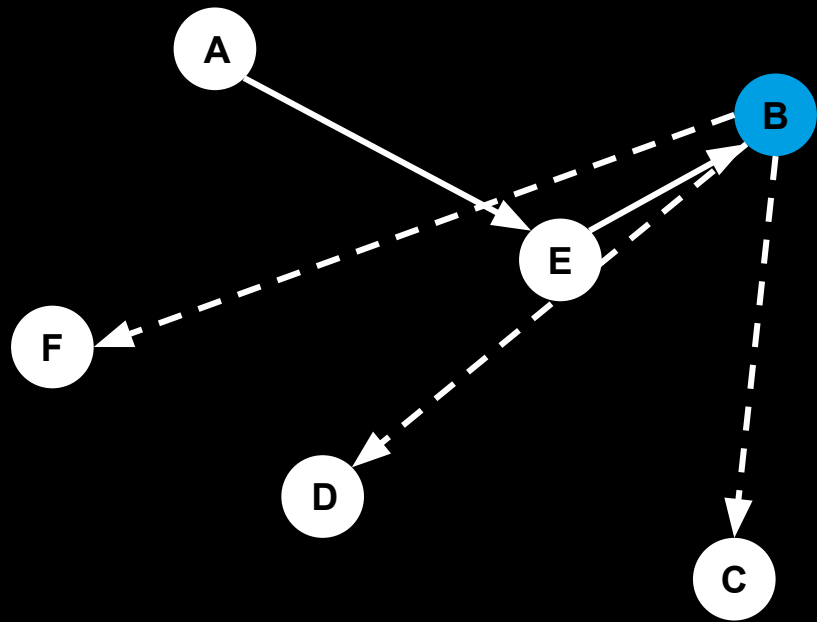
5 possible cities



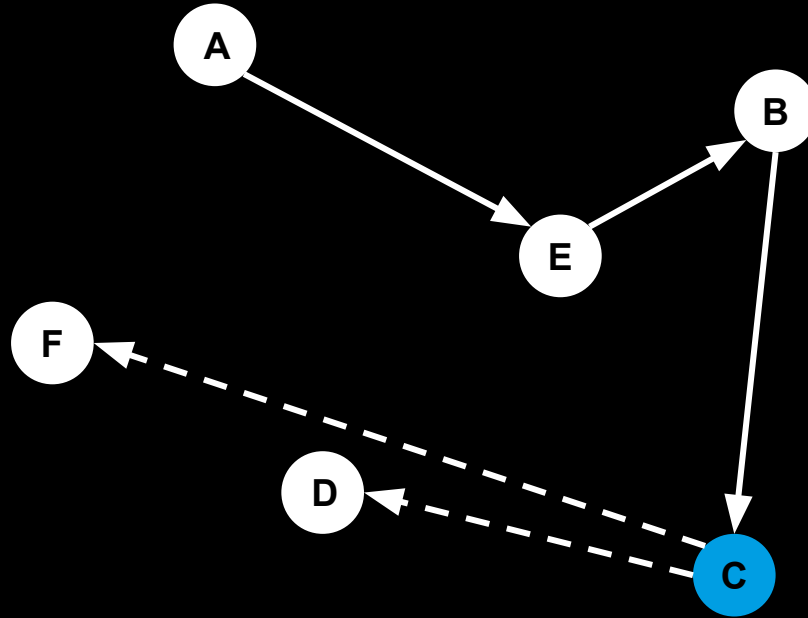
5 4 possible cities



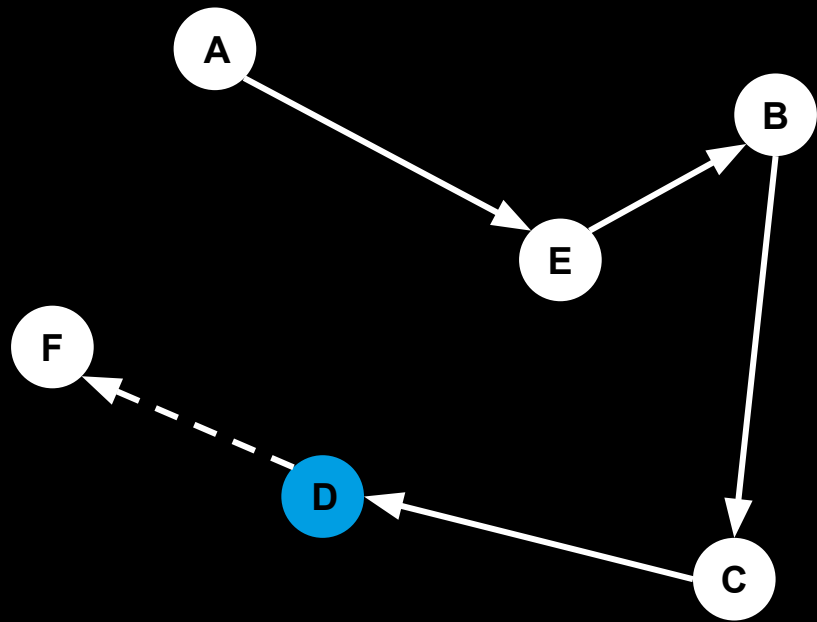
5 4 3 possible cities



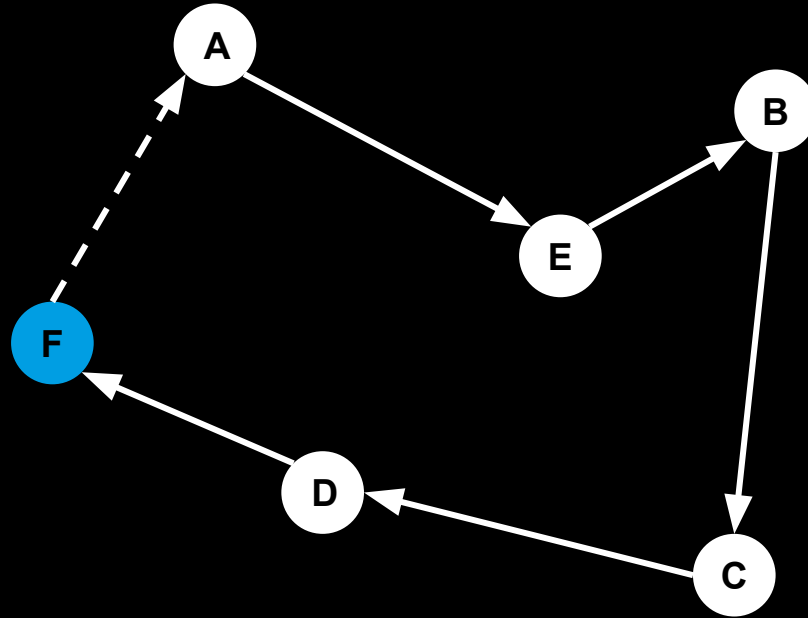
5 4 3 2 possible cities



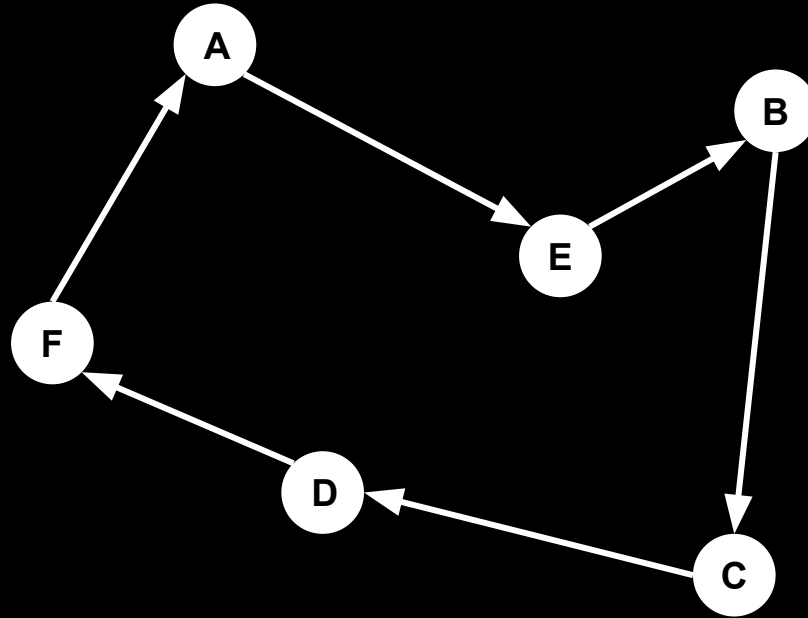
5 4 3 2 1 possible city



5 4 3 2 1 return nome



5 4 3 2 1 return nome



$$O(n) = n!$$

$$n = 5$$

$$O(n) = n!$$

$$n = 5$$

$$N = 5 * 4 * 3 * 2 * 1$$

$$O(n) = n!$$

$$n = 5$$

$$N = 5 * 4 * 3 * 2 * 1$$

$$= 120$$

$$n = 10$$

$$n = 20$$

$$n = 30$$

$$n = 25$$

brute force takes longer than the universe is old

$$n = 60$$

more possible routes than atoms in the universe

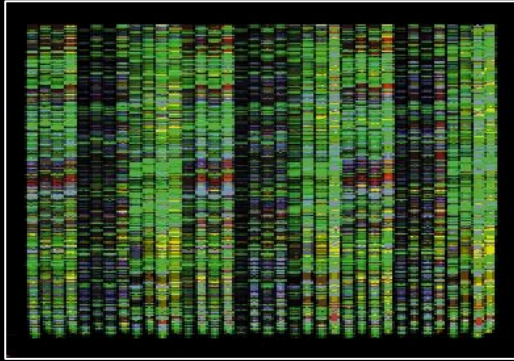


Image source: [IEEE](#)

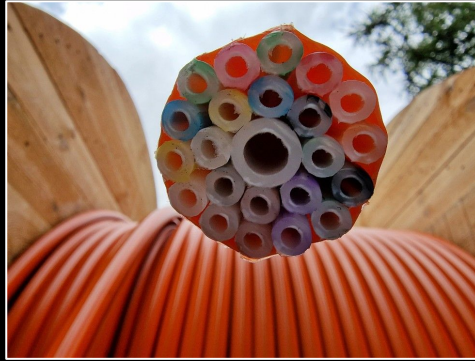


Image source: [VDI Nachrichten](#)



Image source: [Wikimedia](#)

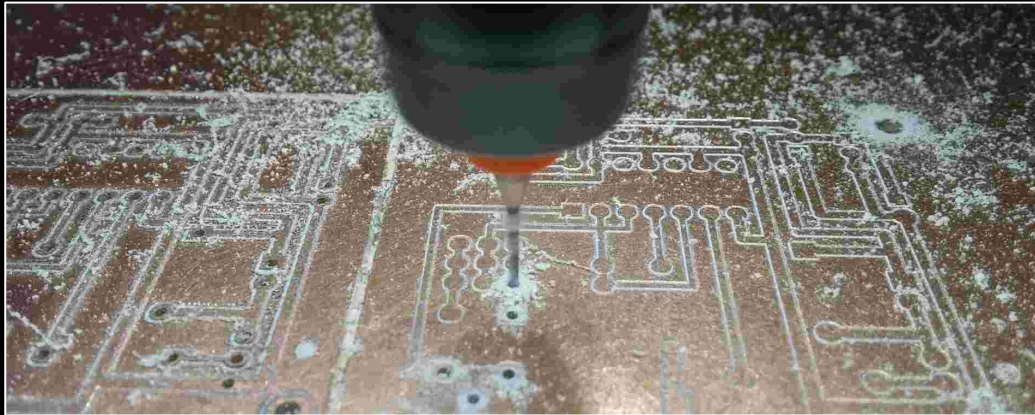
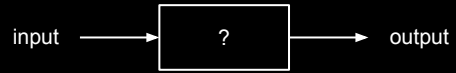


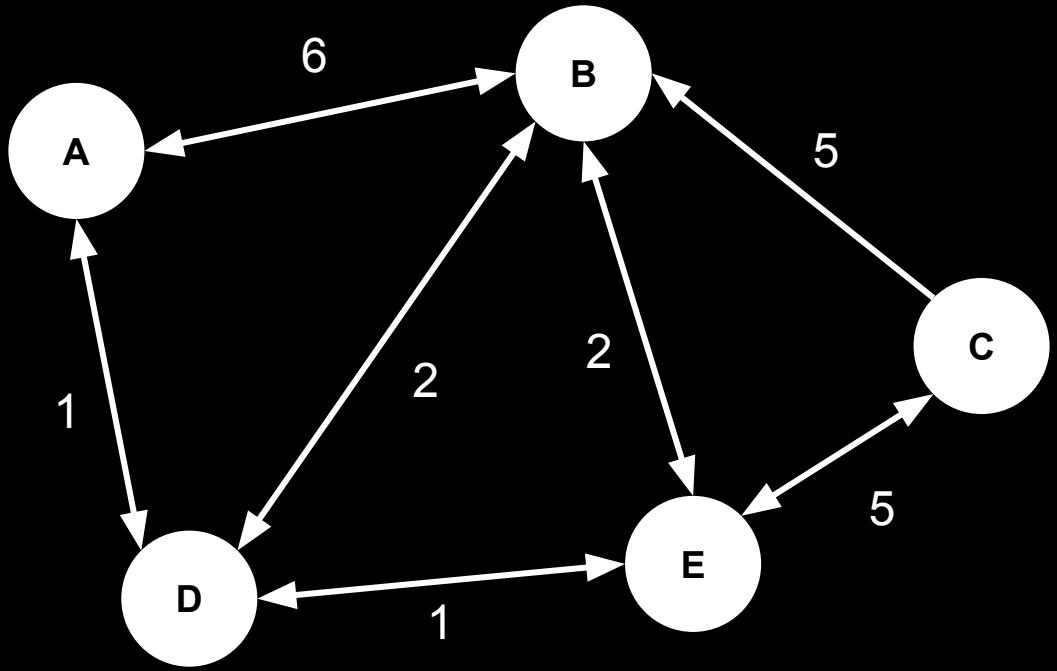
Image source: <https://github.com/meiyi1986/tutorials/blob/master/notebooks/img/pcb-drilling.jpeg>



Image source: [IAS Observatory](#)



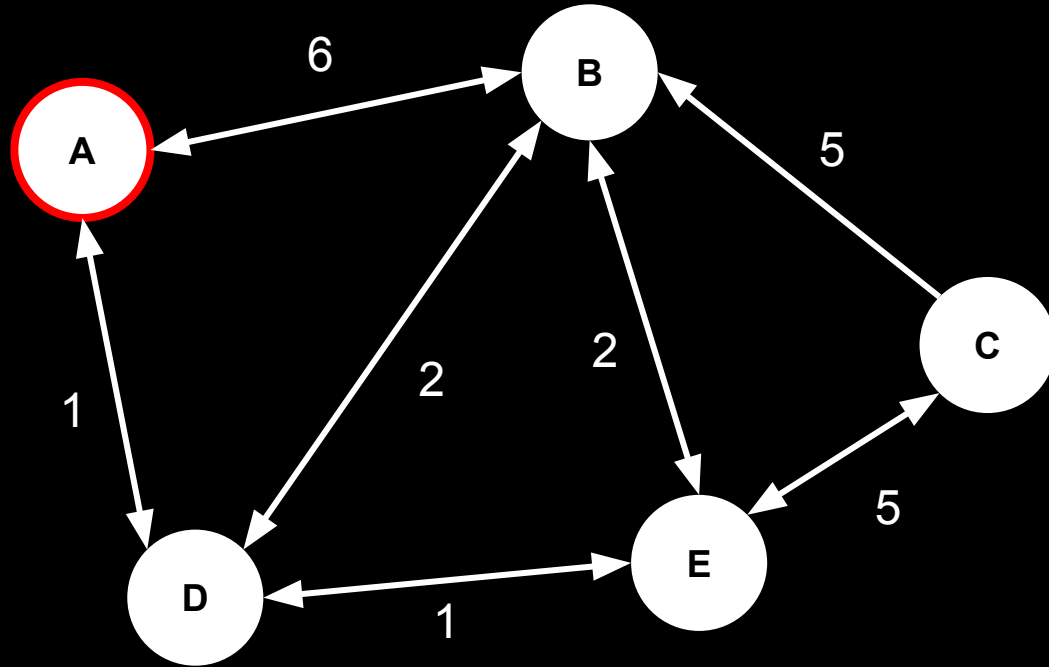
shortest paths



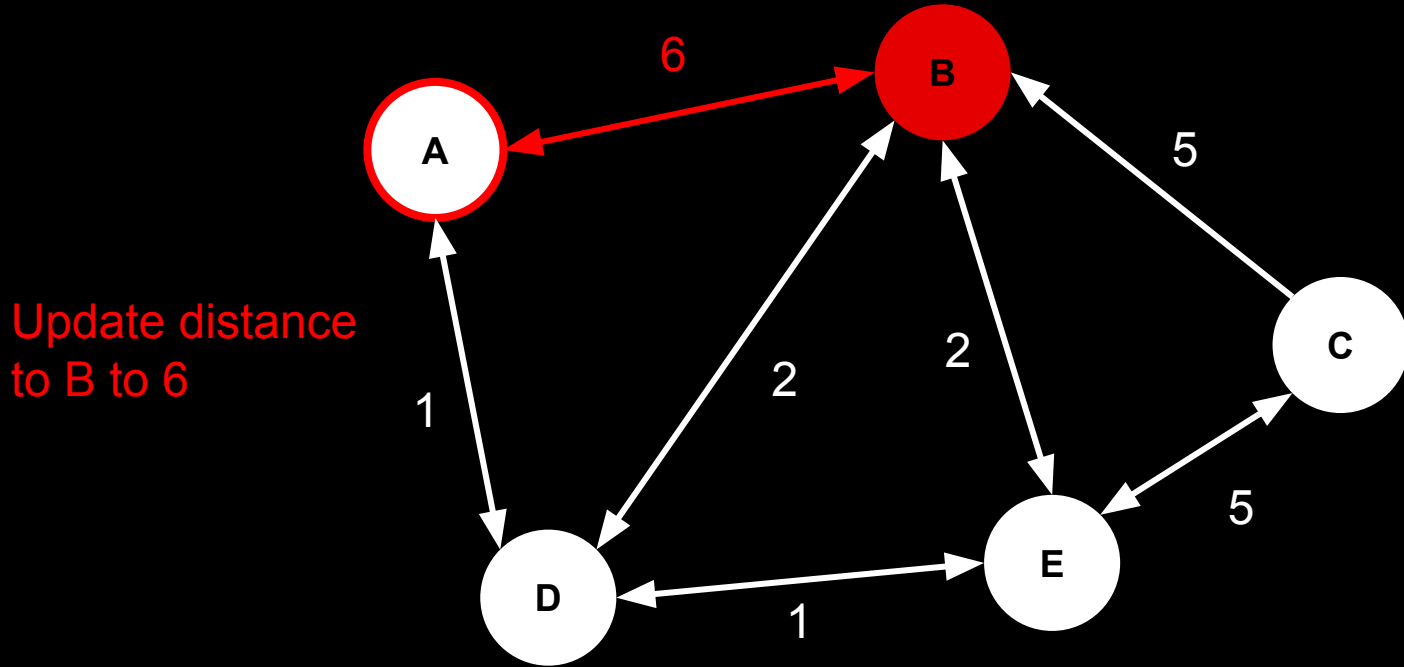
dijkstra's algorithm

Distances: $A = 0$, $B = \infty$, $C = \infty$, $D = \infty$, $E = \infty$

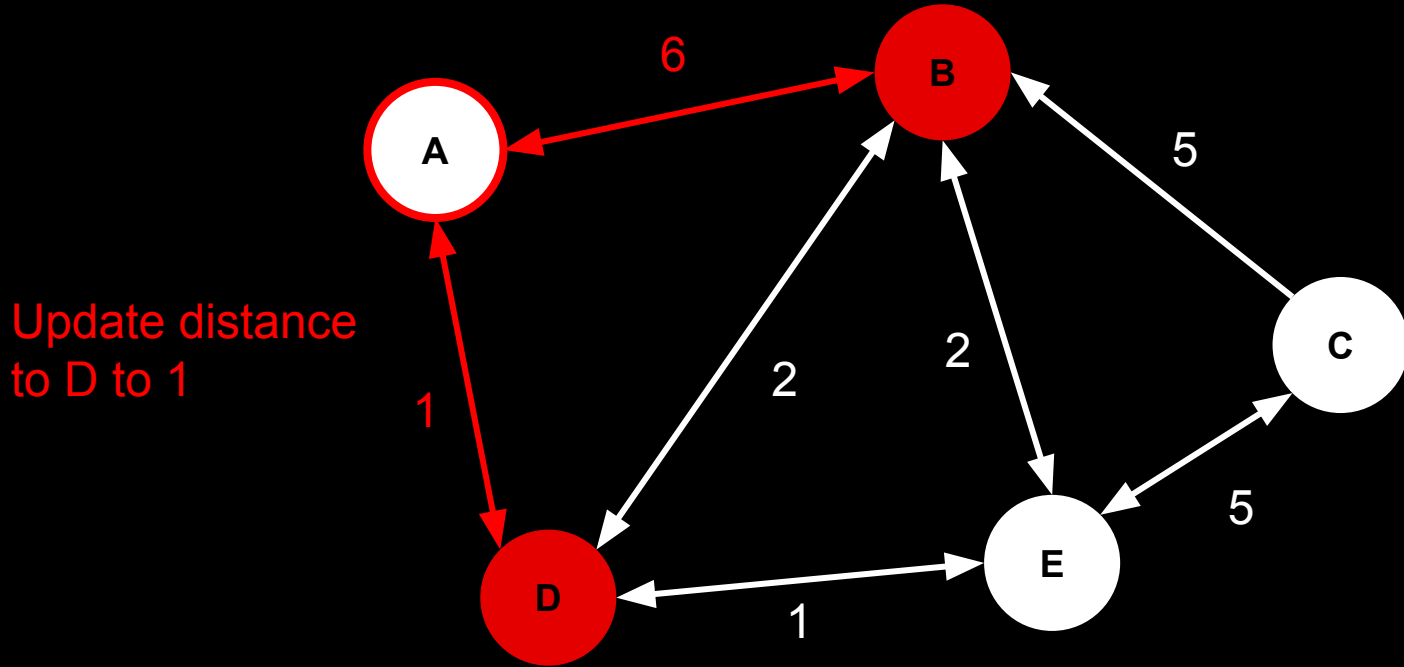
Set A as first location



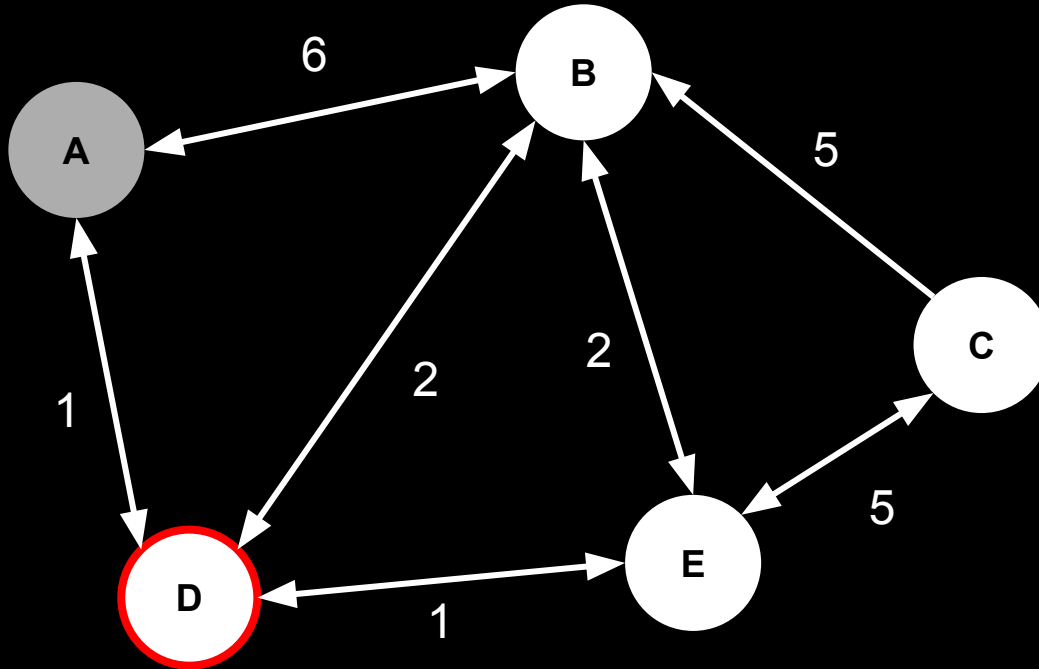
Distances: $A = 0$, $B = 6$, $C = \infty$, $D = \infty$, $E = \infty$



Distances: $A = 0$, $B = 6$, $C = \infty$, $D = 1$, $E = \infty$



Distances: $A = 0$, $B = 6$, $C = \infty$, $D = 1$, $E = \infty$

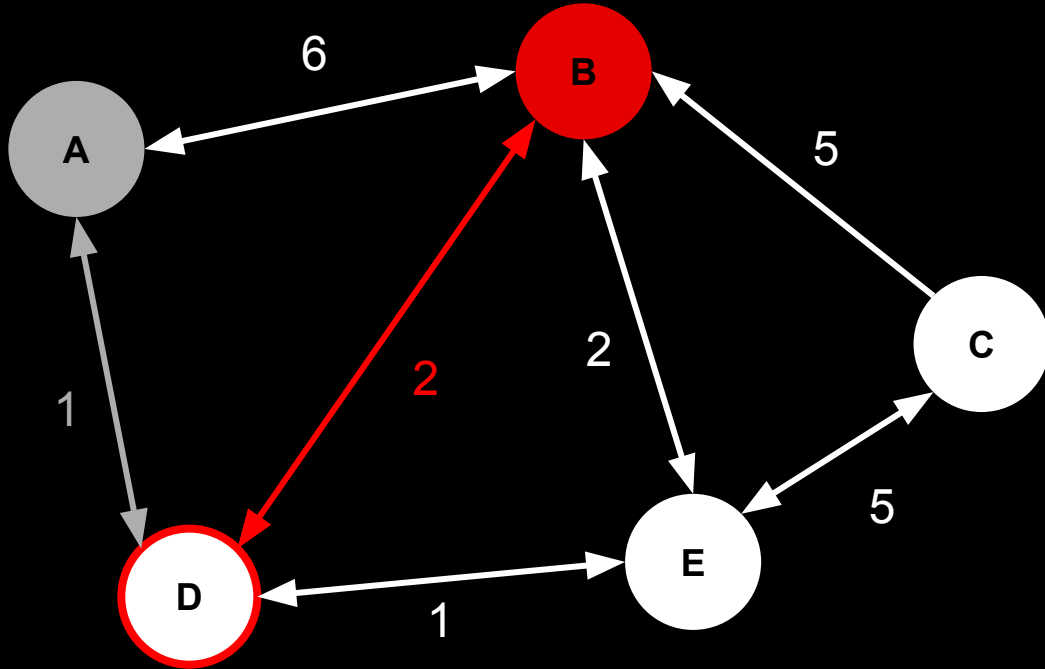


Move to D as
next location

Mark A as
visited

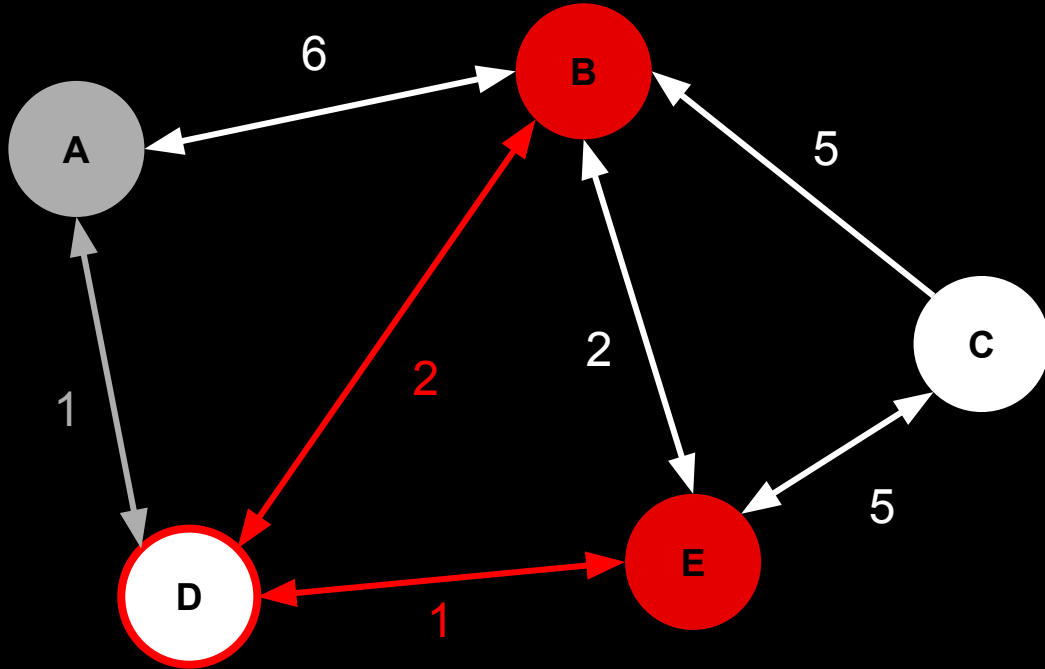
Distances: A = 0, B = 3, C = ∞ , D = 1, E = ∞

Update distance
to B to 3

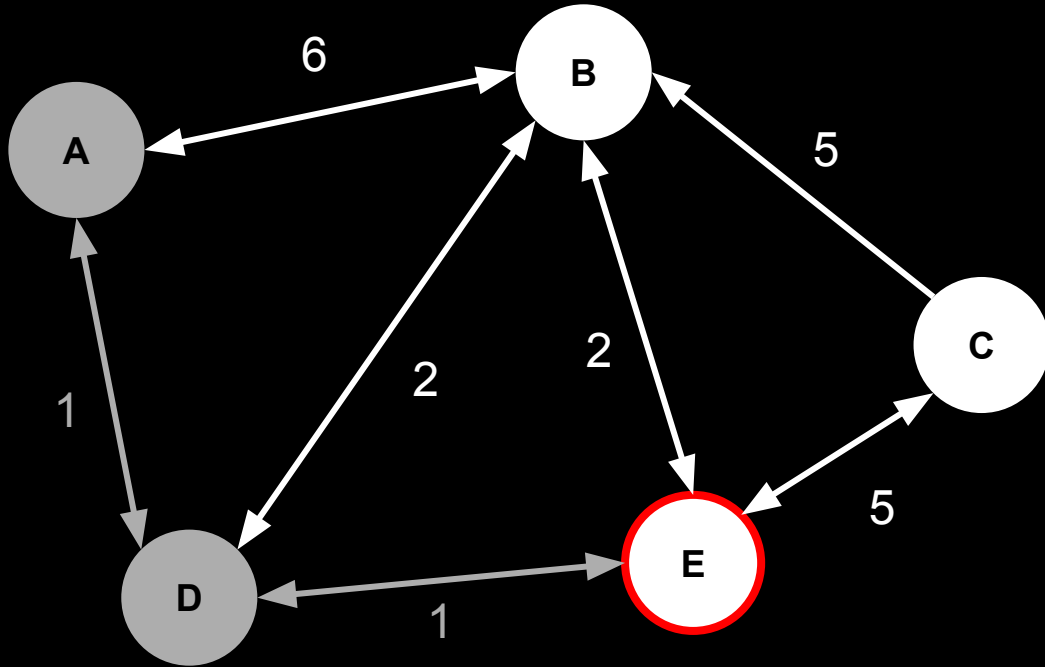


Distances: A = 0, B = 3, C = ∞ , D = 1, E = 2

Update distance
to E to 2



Distances: A = 0, B = 3, C = ∞ , D = 1, E = 2

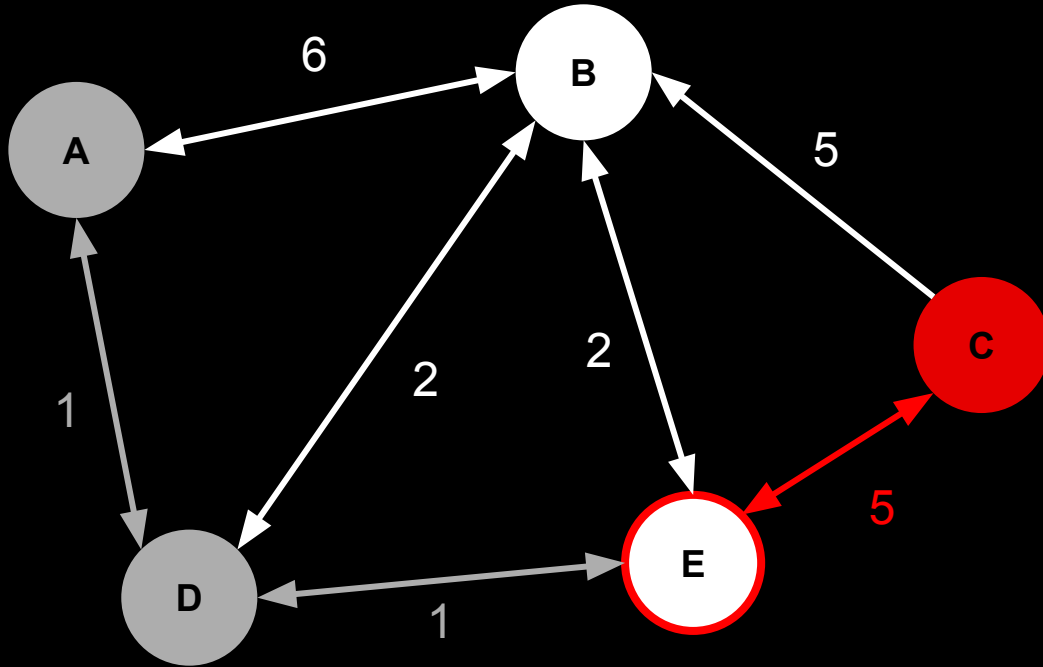


Move to E as
next location

Mark D as
visited

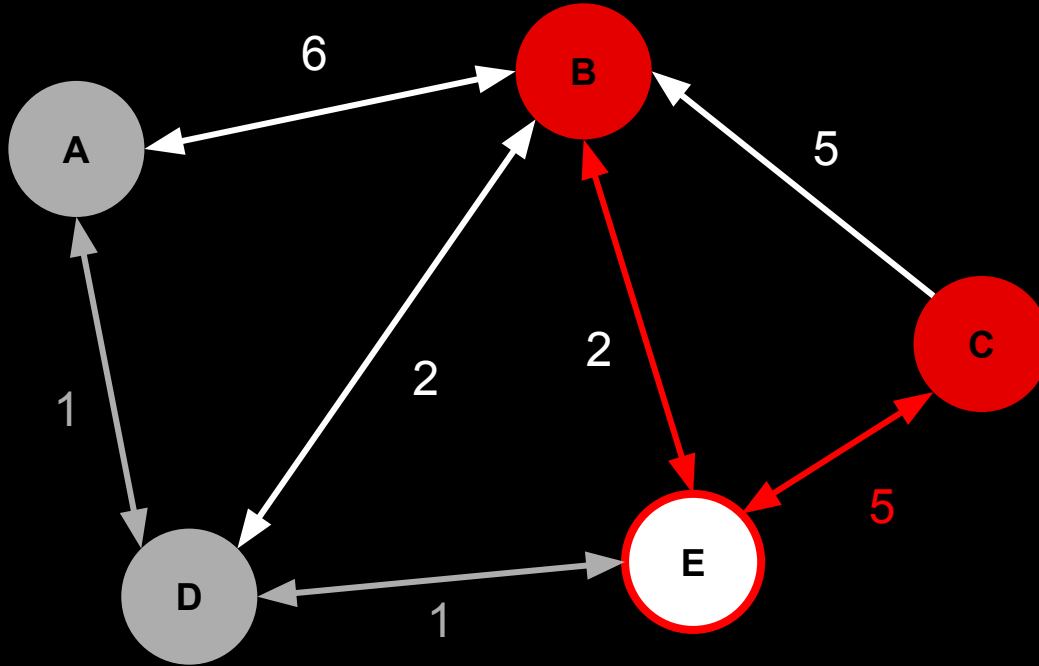
Distances: A = 0, B = 3, C = 7, D = 1, E = 2

Update distance
to C to 7

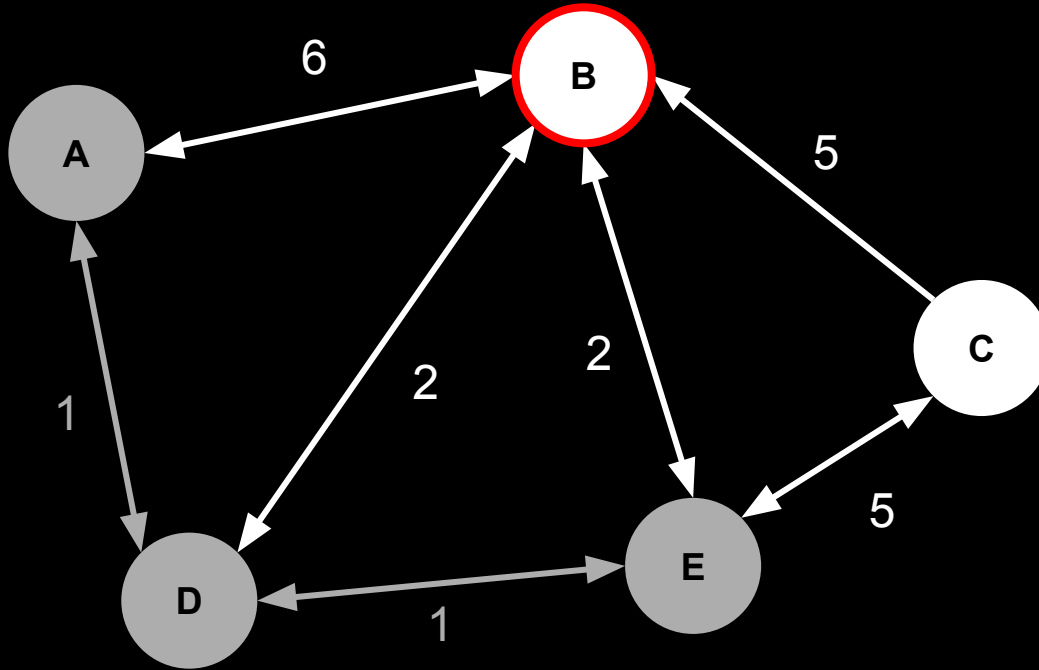


Distances: A = 0, B = 3, C = 7, D = 1, E = 2

No update for B,
shorter path
exists



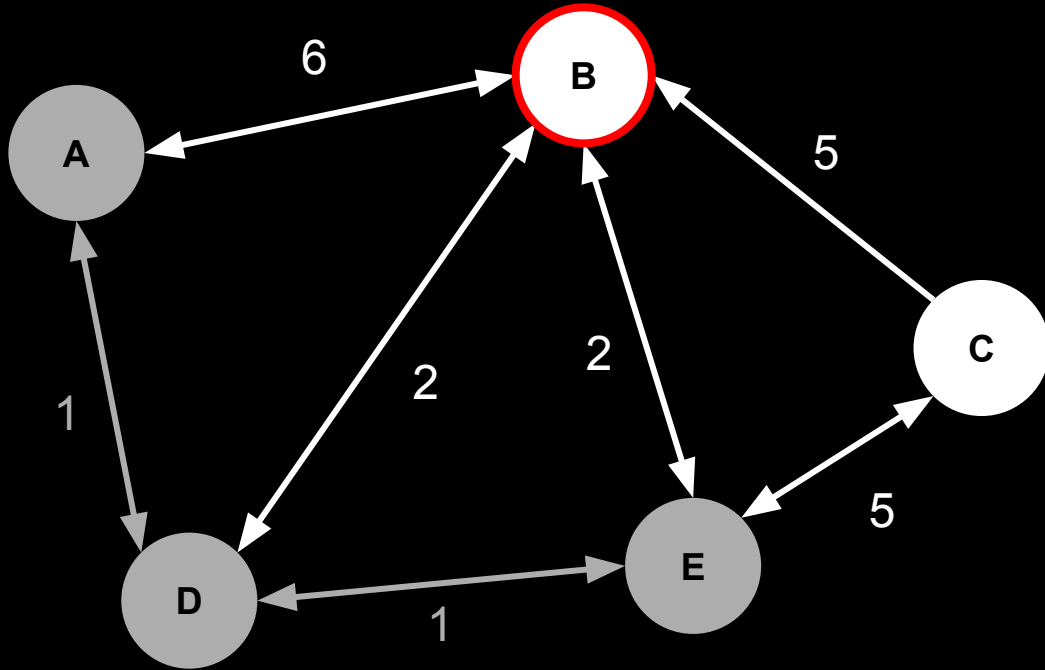
Distances: A = 0, B = 3, C = 7, D = 1, E = 2



Move to B as
new location

Mark E as
visited

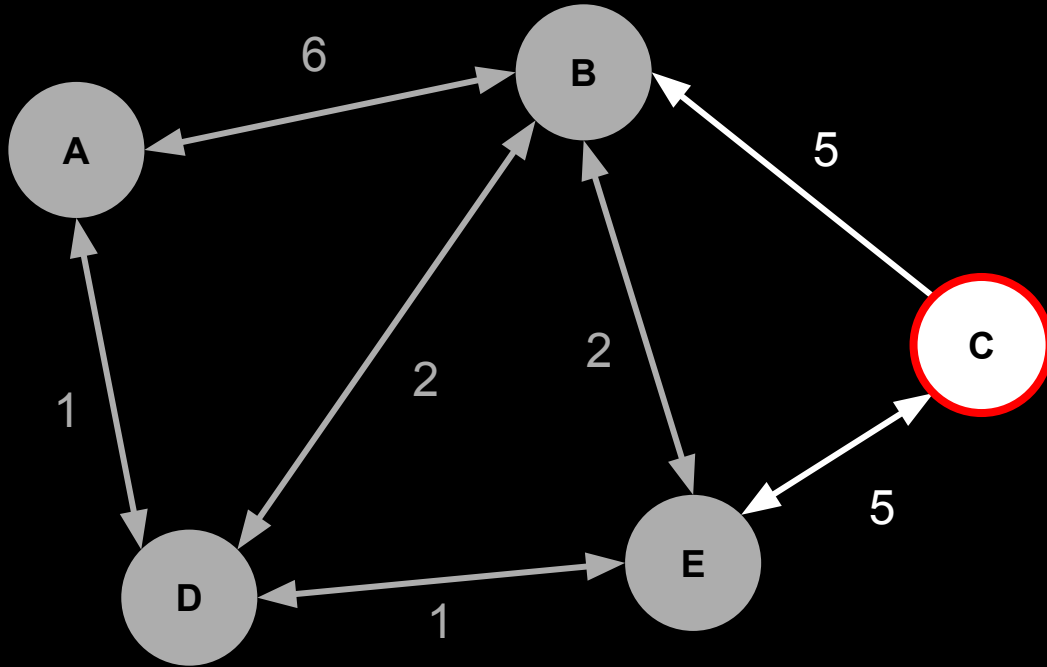
Distances: A = 0, B = 3, C = 7, D = 1, E = 2



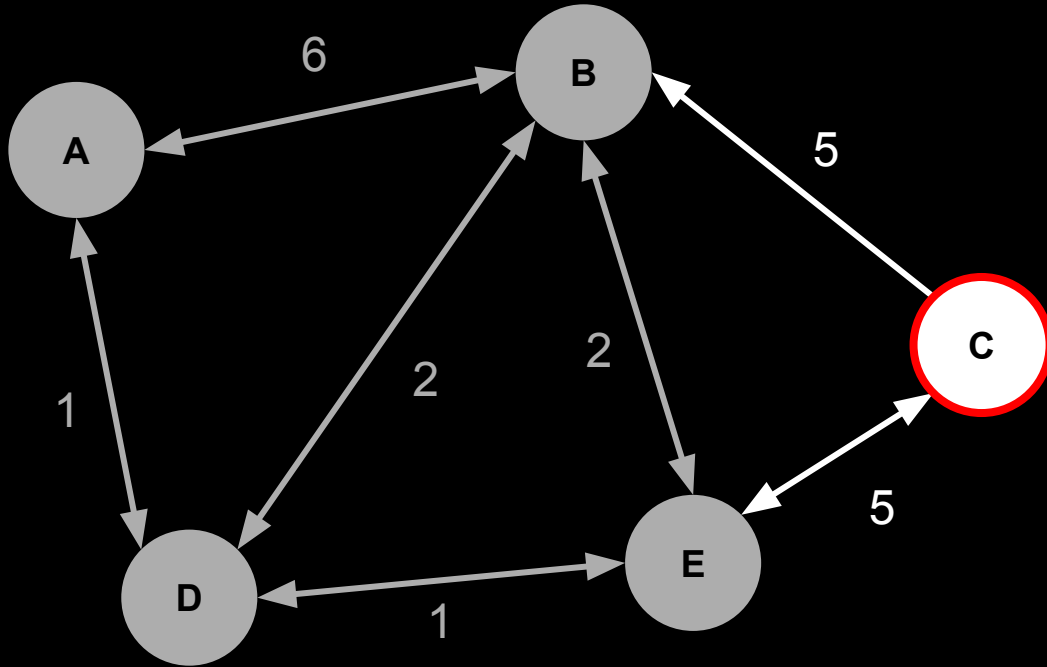
No further
locations
reachable
from B

Distances: A = 0, B = 3, C = 7, D = 1, E = 2

Move to C as
new location

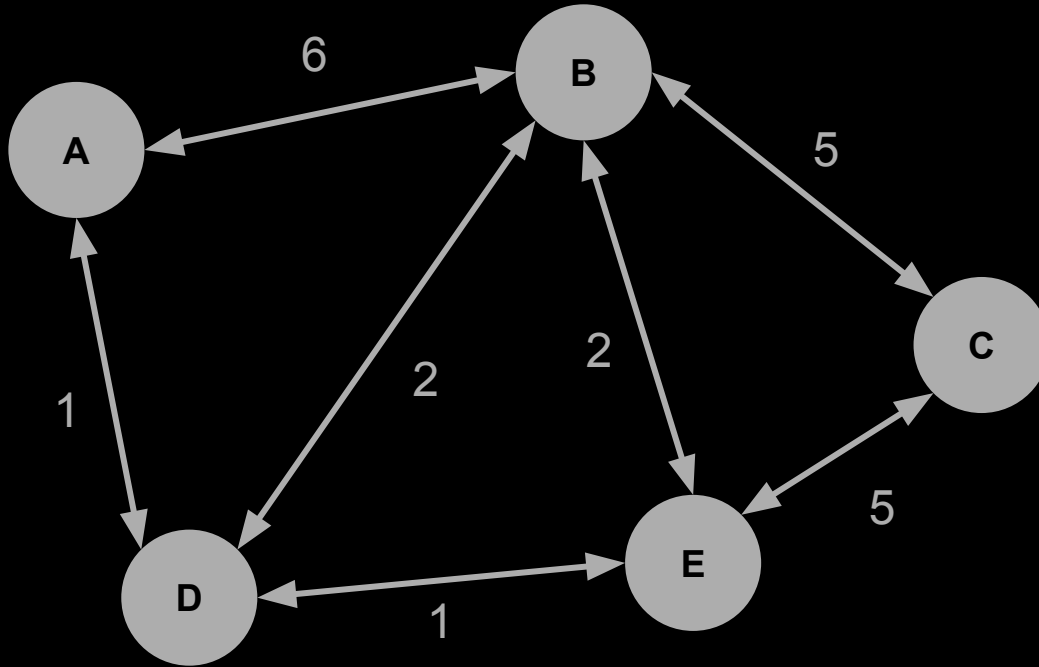


Distances: A = 0, B = 3, C = 7, D = 1, E = 2



No further
locations
reachable from
C

Distances: A = 0, B = 3, C = 7, D = 1, E = 2



All nodes
visited, we're
done!



spam emails



finding oranges in images

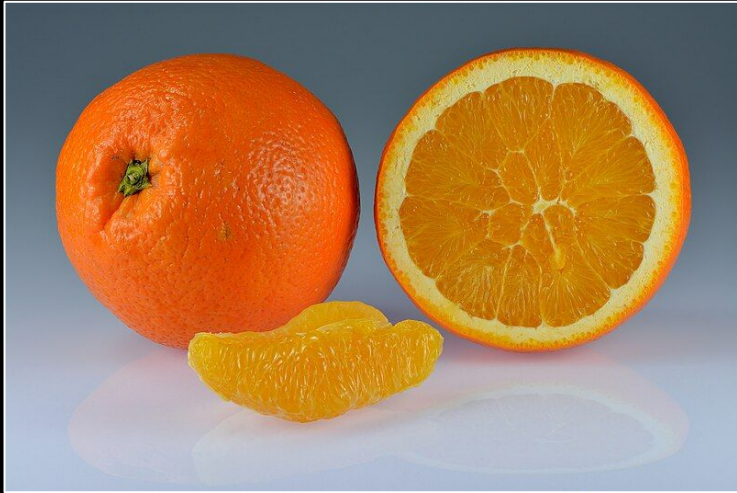


Image source: [Wikimedia](#)

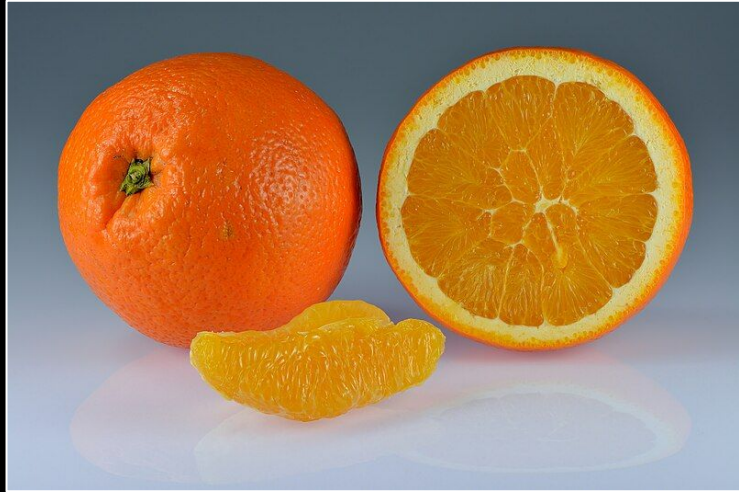


Image source: [Wikimedia](#)

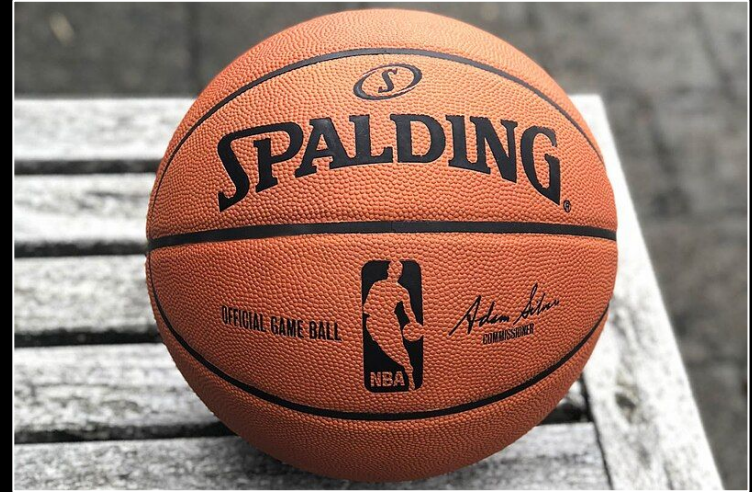
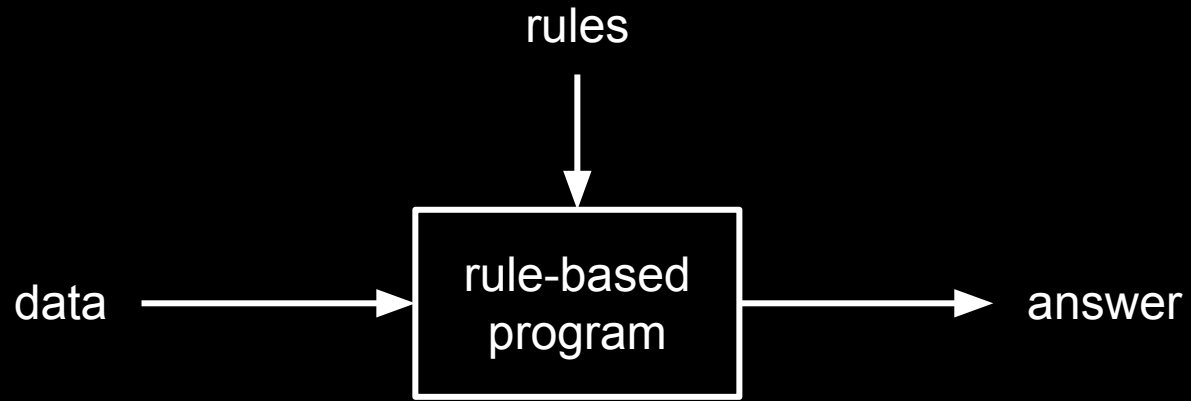
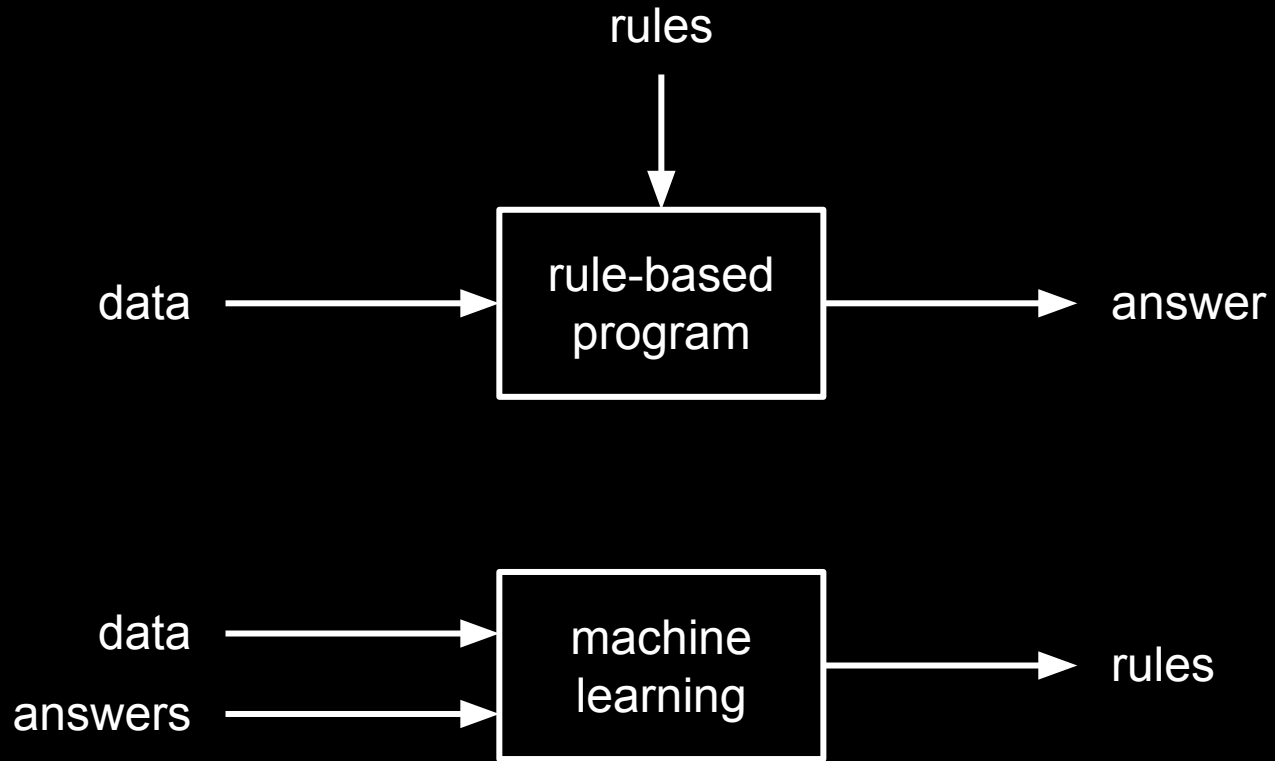


Image source: [Wikimedia](#)

what set of rules can solve this?

machine learning algorithms

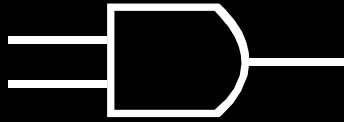




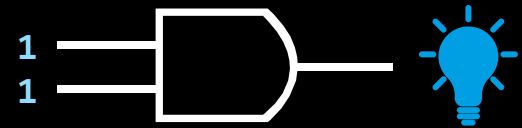
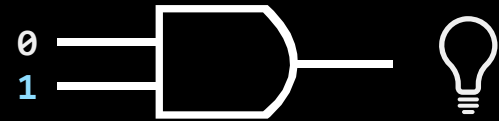
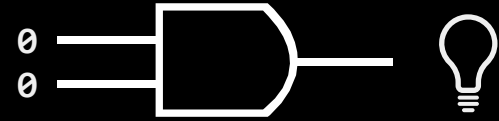
LOGIC AND ARITHMETIC

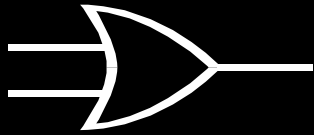
logic gates are the parts a computer is made of.

combined in the right way, they enable the basic arithmetic operations a computer can do:
add, subtract, divide, and multiply.

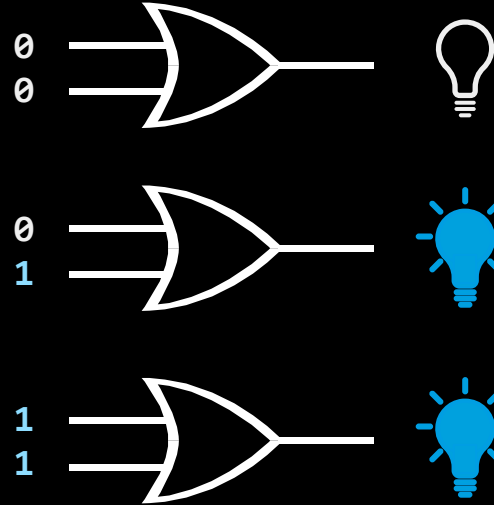


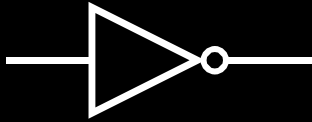
AND	0	1
0	0	0
1	0	1



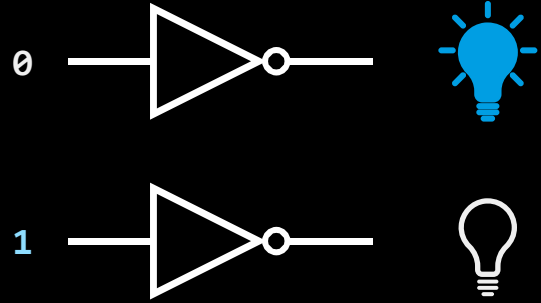


OR	0	1
0	0	1
1	1	1



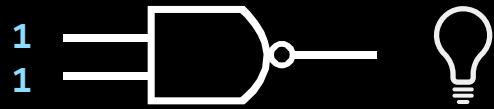
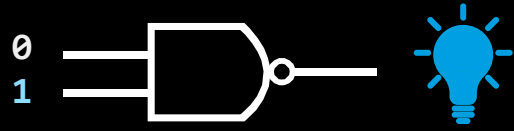
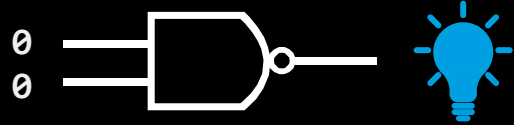


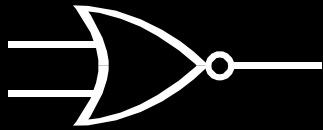
NOT	0	1
	1	0



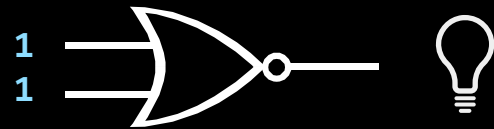
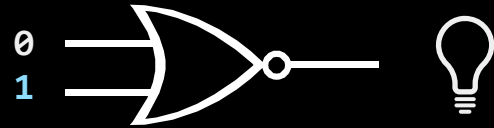
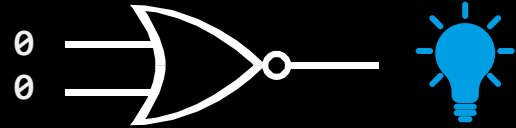


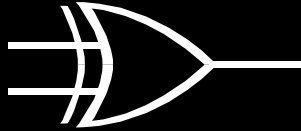
NAND	0	1
0	1	1
1	1	0



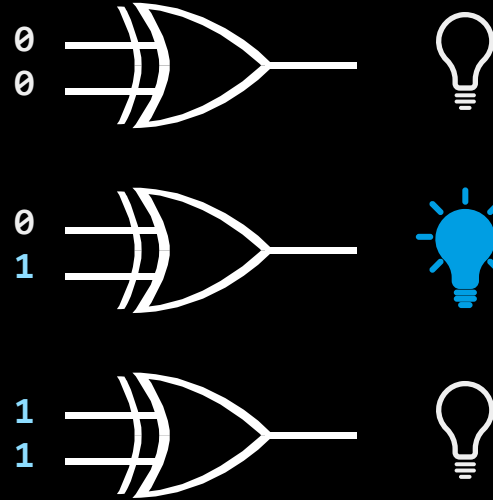


NOR	0	1
0	1	0
1	0	0



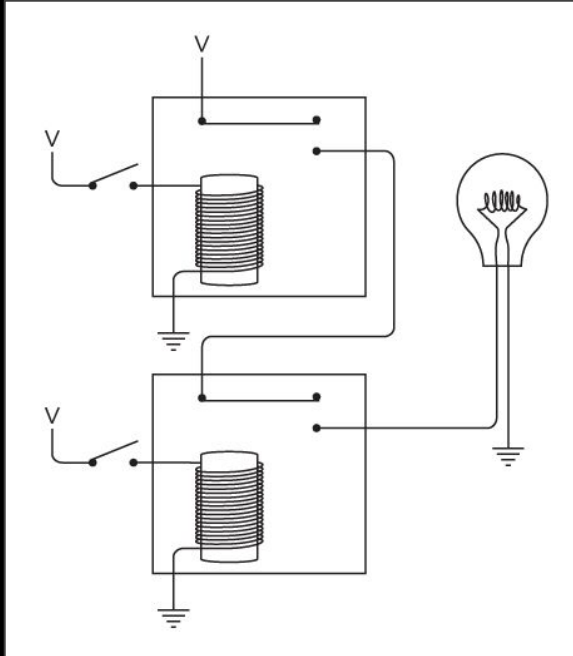


XOR	0	1
0	0	1
1	1	0

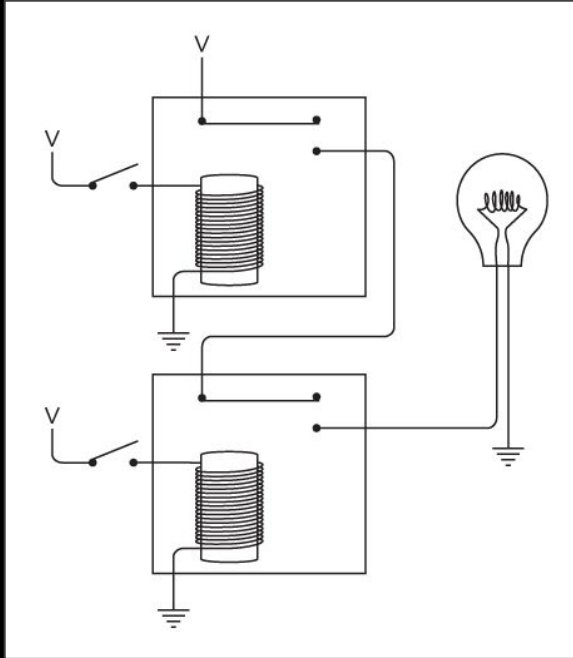


building a logic gate

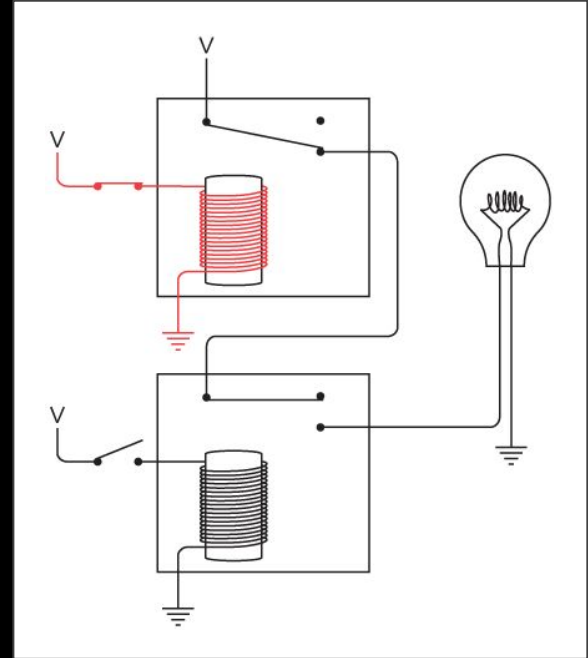
both inputs off



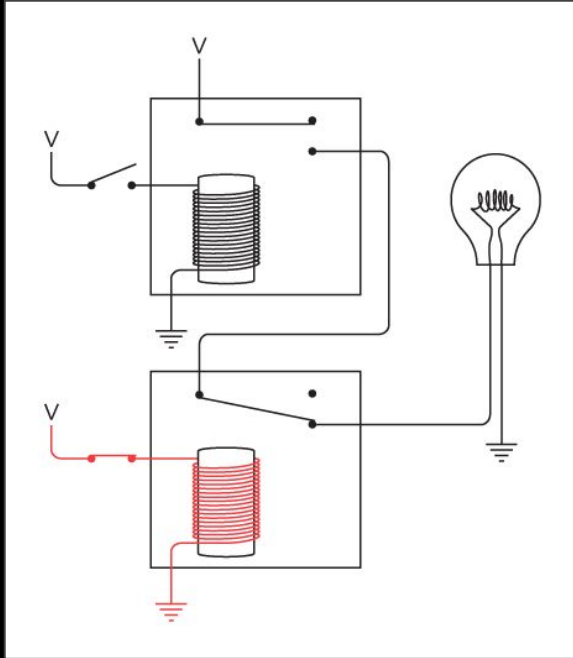
both inputs off



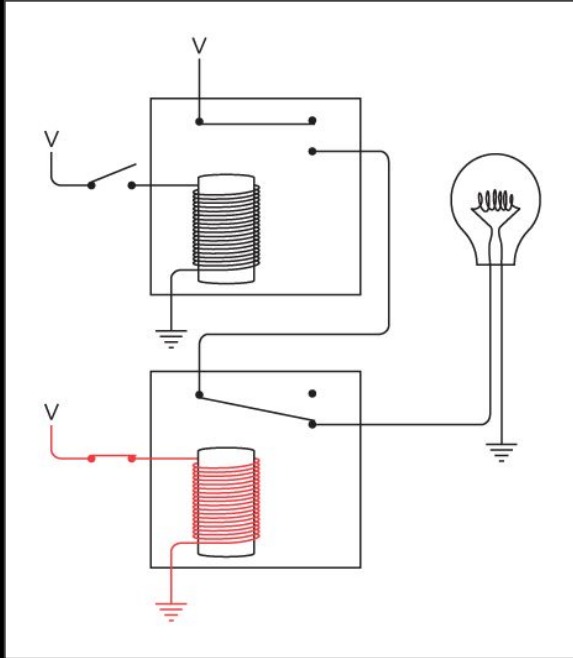
one input on



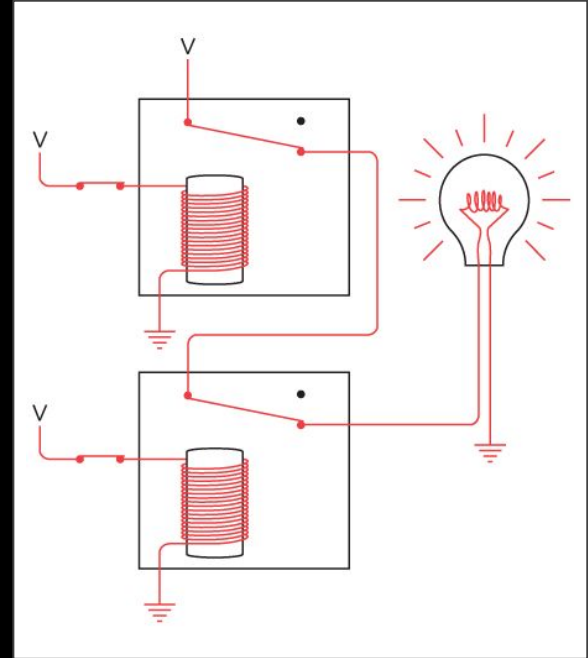
the other input on



the other input on



both inputs on



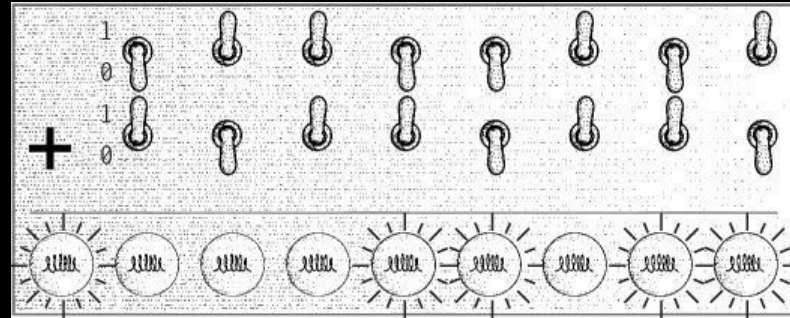
binary addition

when you come right down to it, **addition** is just about the only thing that computers do.

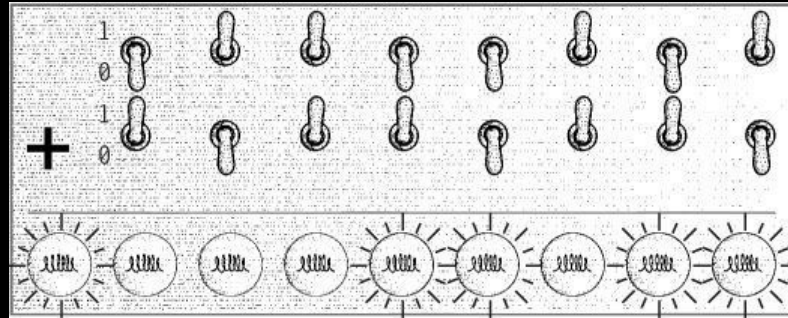
if we can build something that adds, we're well on our way to building something that uses addition to also subtract, multiply, divide, calculate mortgage payments, guide rockets to Mars, play chess, and foul up our phone bills.

(Charles Petzold)

an 8-bit binary adding machine



an 8-bit binary adding machine



maximum result:

$$255 + 255 = 510$$

OR

$$1\ 1111\ 1110$$

How can we add two binary numbers?

$$\begin{array}{r} 1\ 1\ 1\ 0 \\ +\ 1\ 0\ 1\ 0 \\ \hline \end{array}$$

How can we add two binary numbers?

$$\begin{array}{r} 1\ 1\ 1\ 0 \\ +\ 1\ 0\ 1\ 0 \\ \hline 0 \end{array}$$

How can we add two binary numbers?

$$\begin{array}{r} 1\ 1\ 1\ 0 \\ +\ 1\ 0\ 1\ 0 \\ \hline 0\ 0 \end{array}$$

How can we add two binary numbers?

$$\begin{array}{r} 1\ 1\ 1\ 0 \\ +\ 1\ 0\ 1\ 0 \\ \hline 0\ 0 \end{array}$$

How can we add two binary numbers?

$$\begin{array}{r} 1\ 1\ 1\ 0 \\ +\ 1\ 0\ 1\ 0 \\ \hline 0\ 0\ 0 \end{array}$$

How can we add two binary numbers?

$$\begin{array}{r} 1\ 1\ 1\ 0 \\ +\ 1\ 0\ 1\ 0 \\ \hline 0\ 0\ 0 \end{array}$$

How can we add two binary numbers?

$$\begin{array}{r} 1\ 1\ 1\ 0 \\ +\ 1\ 0\ 1\ 0 \\ \hline 1\ 0\ 0\ 0 \end{array}$$

How can we add two binary numbers?

$$\begin{array}{r} 1110 \\ + 1010 \\ \hline 11000 \end{array}$$

adding two bits

+	0	1
0		
1		

+	0	1
0	0	
1		

+	0	1
0	0	1
1		

+	0	1
0	0	1
1	1	

+	0	1
0	0	1
1	1	10

+	0	1
0	0	1
1	1	10

OR

+	0	1
0	00	01
1	01	10

+	0	1
0	0	1
1	1	10

OR


+	0	1
0	00	01
1	01	10

the digit on the right, we call the **sum bit**
the left digit, we call ...?

+	0	1
0	0	1
1	1	10

OR

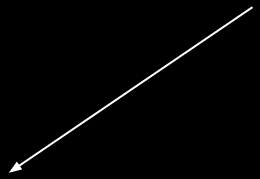
+	0	1
0	00	01
1	01	10



the digit on the right, we call the **sum bit**
the left digit, we call the **carry bit**

+	0	1
0	0 0	0 1
1	0 1	1 0

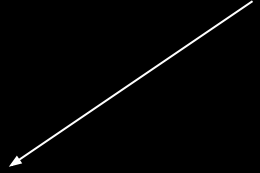
+	0	1
0	0 0	0 1
1	0 1	1 0



sum bit

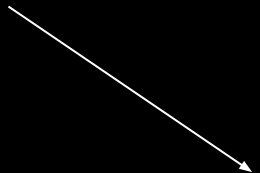
+	0	1
0	0	1
1	1	0

+	0	1
0	0 0	0 1
1	0 1	1 0



sum bit

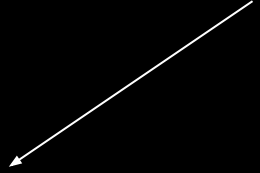
+	0	1
0	0	1
1	1	0



carry bit

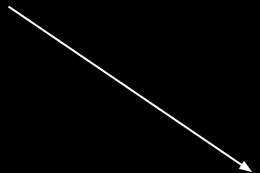
+	0	1
0	0	0
1	0	1

+	0	1
0	0 0	0 1
1	0 1	1 0



sum bit

+	0	1
0	0	1
1	1	0

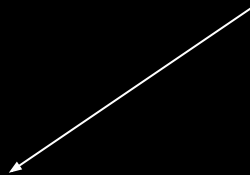


carry bit

+	0	1
0	0	0
1	0	1

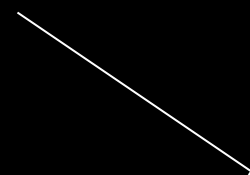
doesn't this look familiar?

+	0	1
0	0 0	0 1
1	0 1	1 0



sum bit

+	0	1
0	0	1
1	1	0



carry bit

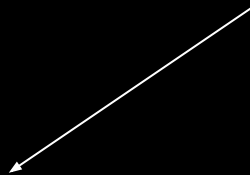
+	0	1
0	0	0
1	0	1

doesn't this look familiar?



AND	0	1
0	0	0
1	0	1

+	0	1
0	0 0	0 1
1	0 1	1 0

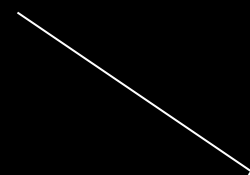


sum bit

+	0	1
0	0	1
1	1	0



XOR	0	1
0	0	1
1	1	0



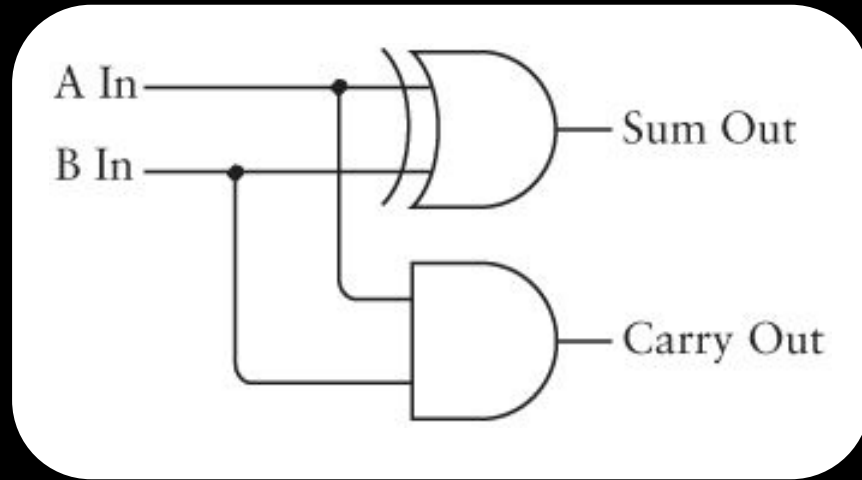
carry bit

+	0	1
0	0	0
1	0	1

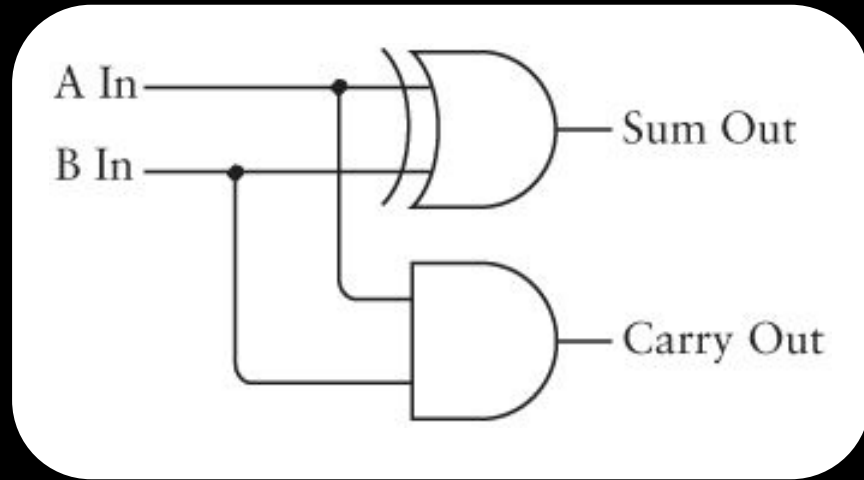


AND	0	1
0	0	0
1	0	1

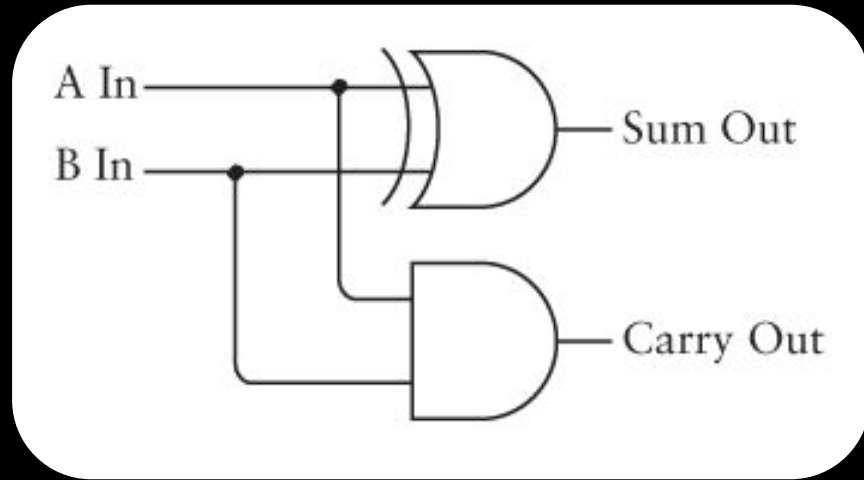
doesn't this look familiar?



bits A and B
are inputs

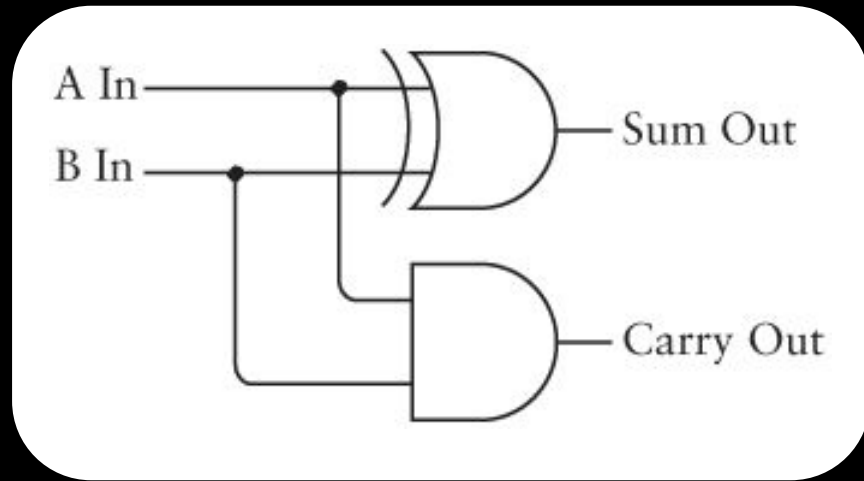


bits A and B
are inputs



XOR gate
computes sum bit

bits A and B
are inputs

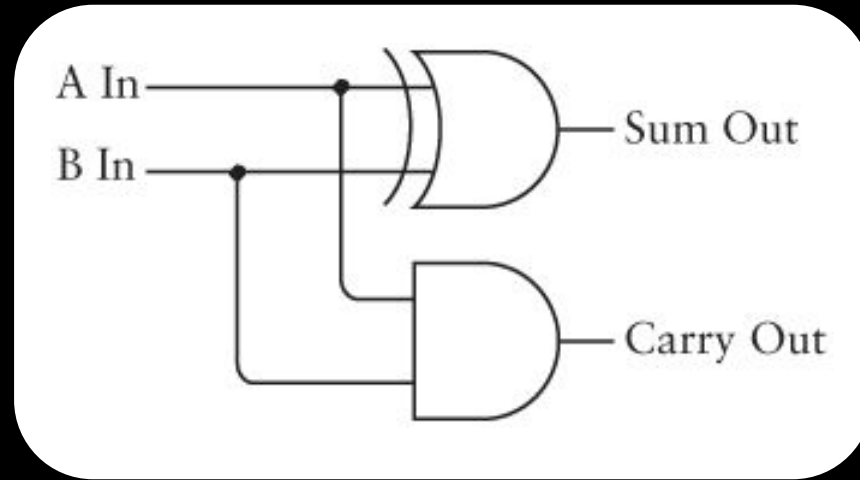


XOR gate
computes sum bit

AND gate
computes carry bit

half adder

bits A and B
are inputs

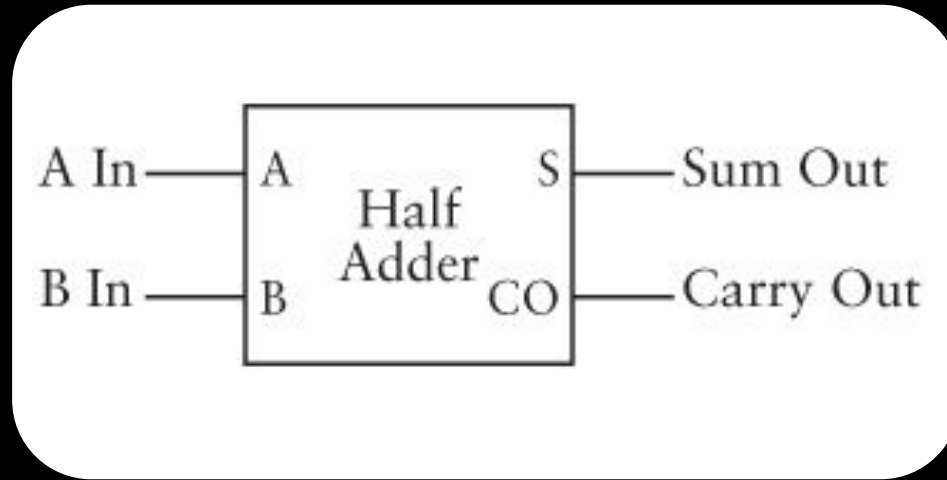


XOR gate
computes sum bit

AND gate
computes carry bit

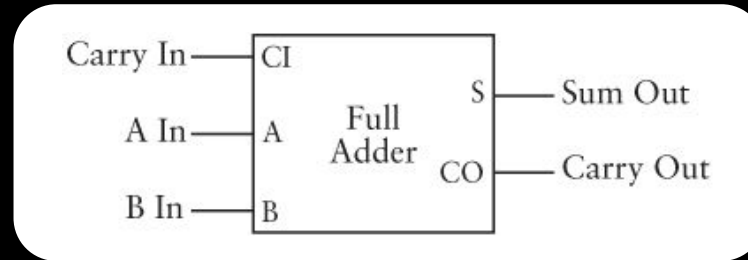
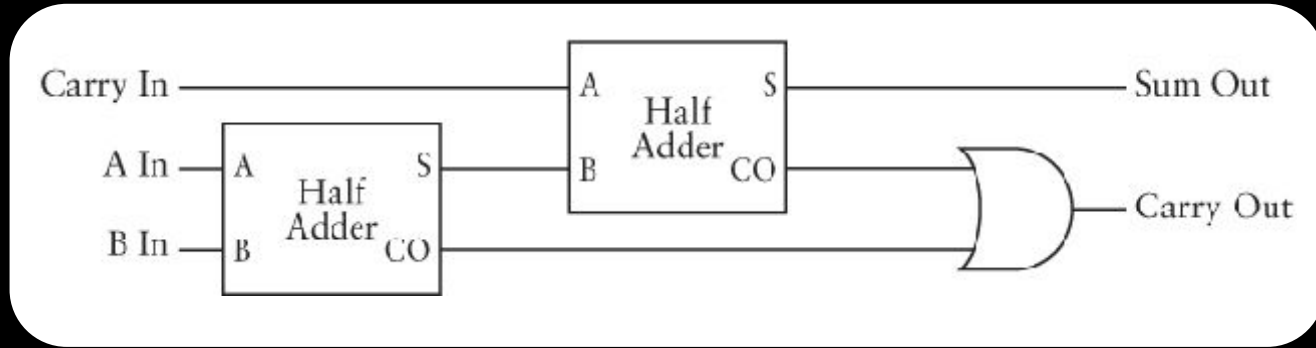


half adder

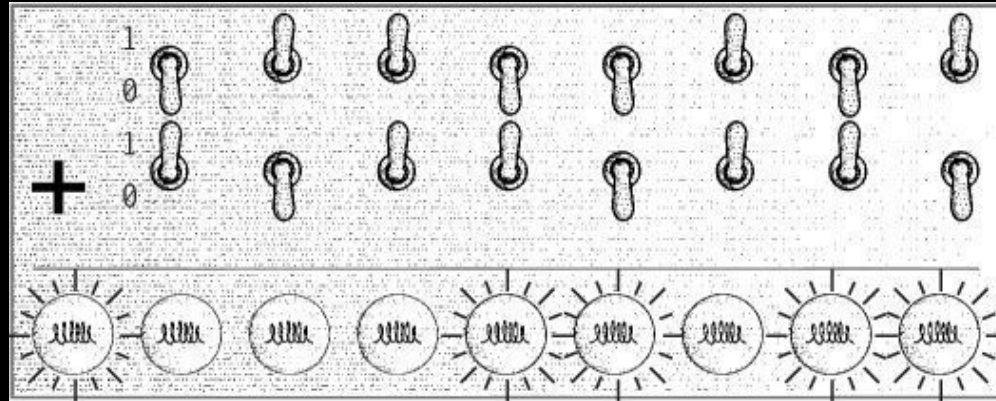


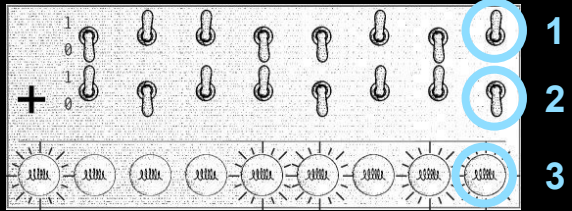
the half adder has no input for a carry bit.

two half adder wired together make a full adder.



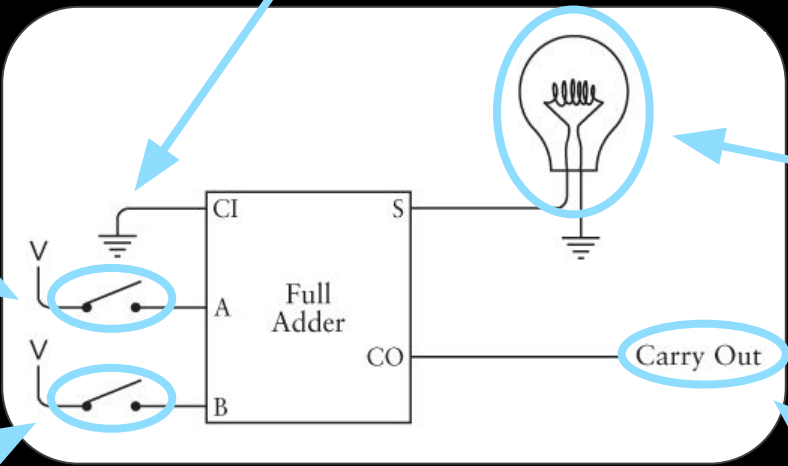
so how to build this?





no carry bit for 1st digits

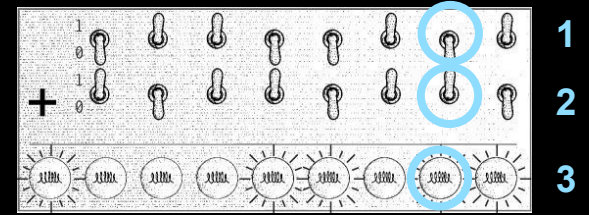
switch 1st byte, 1st digit (1)



result for rightmost digit (3)

switch 2nd byte, 1st digit (2)

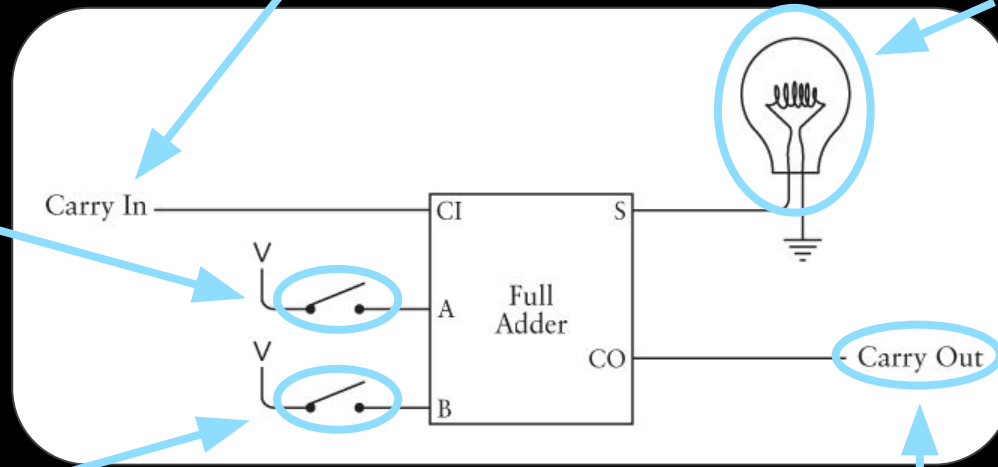
this is carried to the next full adder



carry bit from 1st digits

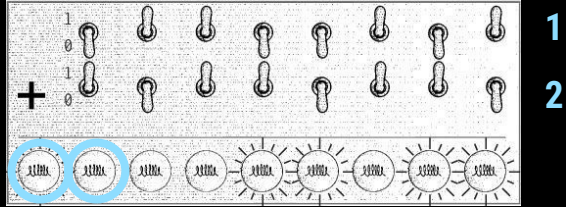
result for 2nd rightmost digit (3)

switch 1st byte, 2nd digit (1)



switch 2nd byte, 2nd digit (2)

this is carried to the next full adder



1
2

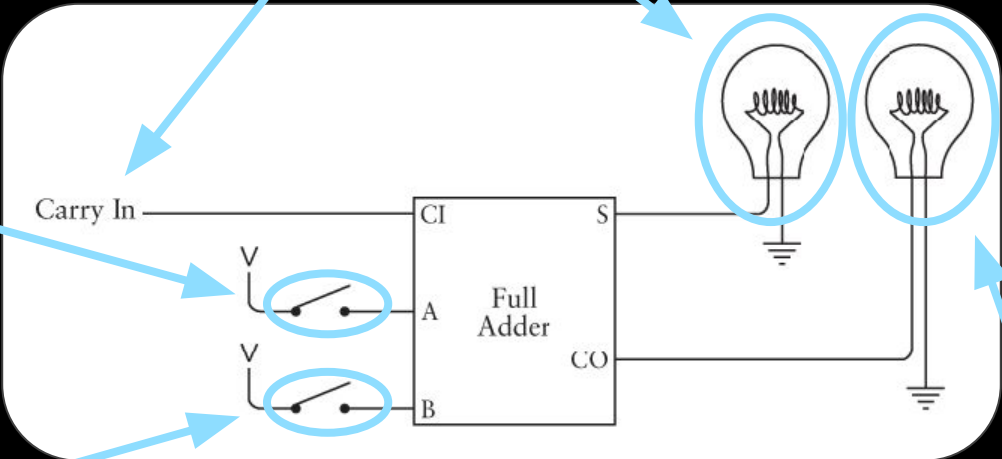
4

3

result for 8th digits (3)

carry bit from 7th digits

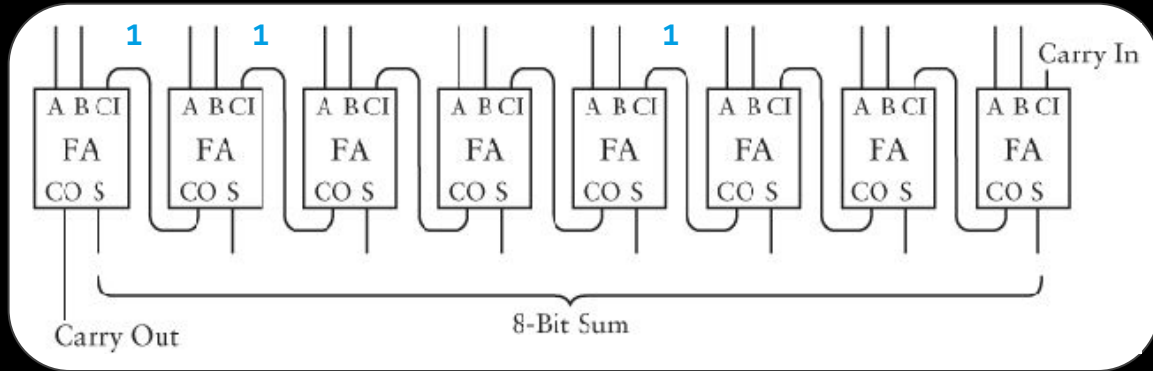
switch 1st byte, 8th digit (1)



switch 2nd byte, 8th digit (2)

result for the 9th digit (4)

0 1 1 0 0 1 0 1
1 0 1 1 0 1 1 0

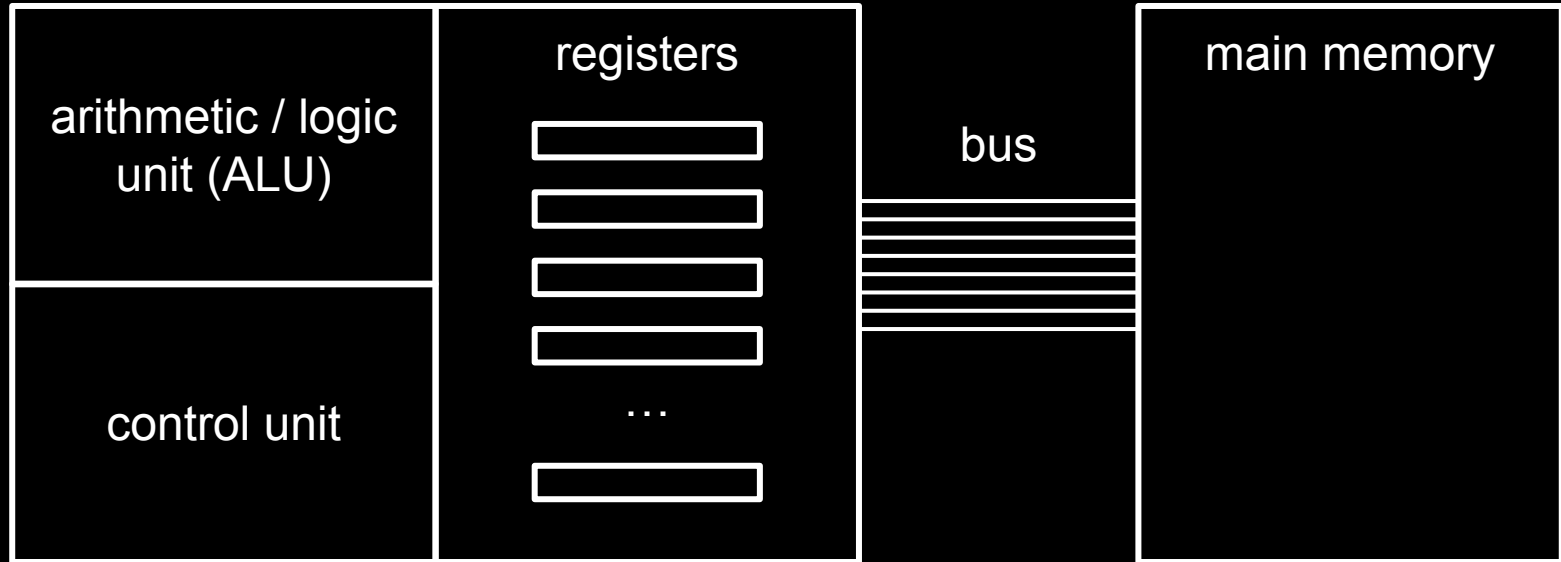


1 0 0 0 1 1 0 1 1

COMPUTERS

hardware and software

central processing unit



mass storage

stored-program concept

machine language

fetch-decode-execute

MEMORY

which is better?



APPENDIX

